

Steadiness & Innovation in Motion control

# SUNG-IL MACHINERY

## PRODUCT CATALOGUE



COUPLING

CONNECTING SHAFT

SAFETY COUPLING

TIMING PULLEY

A.P. LOCK

SUPPORT UNIT FOR BALL-SCREW



**Your Satisfaction is Our Top Priority**



## Mission & Vision

### Mission

To bring happiness to our customer and employees through high-value-added machine components for power transmission in FA industry.

### Vision

To become a specialized No.1 machine component brand with sustainable basis for growth

## Core Value



Customer Satisfaction



Speed



Ownership



Innovation

## Greetings

Since our founding in 1991, Sung-il Machinery Co., Ltd. (S.I.M.) has been committed to producing high-quality motion control components. As Korea's first manufacturer of precision couplings, we take pride in pioneering the localization of a product once entirely dependent on imports. That milestone continues to inspire us as we innovate and grow. Over the years, we've expanded our offerings to include a broad range of couplings and factory automation parts—such as support units for ball screws, connecting shafts, timing pulleys, safety couplings, and A.P. Locks. Through ongoing innovation, we strive to unlock new technological possibilities.

Today, our products reach around 60 countries across the Americas, Europe, Southeast Asia, and the Middle East. With branch offices in China and Japan, we embrace the challenges of global competition with determination. Our goal is to evolve from a leading Korean manufacturer into a true global innovator in motion control.

For over 30 years, our guiding principle has been: “Your satisfaction is our top priority.”

This promise drives our unwavering focus on quality, timely delivery, and competitive pricing—values that define us as a trusted partner to customers worldwide.

We, at Sung-il Machinery Co., Ltd., sincerely thank you for your continued support and cooperation.

# COMPANY INTRODUCTION

## Company Overview

*Customer Satisfaction is Our Top Priority*



Steadiness & Innovation in  
**Motion control**



**1991** (35+years)  
Foundation



since **2022**  
World-Class Product



**120+**  
Global Employees

**Our Core Product Lines**



Ball-Screw  
Support Solutions



Precision Shaft  
Coupling Solutions



Timing Pulley  
Solutions

**Our Strength**



**FLEXIBILITY**  
We adapt to our customers' needs, offering flexible solutions tailored to each requirement.



**VARIETY**  
We offer the widest range of products, providing more options to choose from than our competitors.



**CAPACITY**  
We handle projects of any scale effectively, thanks to our extensive infrastructure and resource base.



**PROGRESS**  
We are committed to continuous improvement and innovation, driving us forward at all times.

**Annual Shipments** unit | Avg / Yr

**1,100,000+**

Coupling

**250,000+**

Support Unit For  
Ball Screw

**70,000+**

Timing Pulley

**1st** First to localize precision shaft couplings in Korea

**No.1** No. 1 market share in Korea for precision shaft couplings (70%+)

**No.1** No. 1 market share in Korea for ball screw support units



Headquarters  
**KOREA**



Global Sites  
KR · CN · JP · US



Sales Territory  
**60+**



Global Customers  
**3500+**

## Company Identity (CI)



The new CI emphasizes SUNG-IL MACHINERY's English initials. It is expected that this simplified logo will bring better branding effect while the name "SUNG-IL MACHINERY" under Korean language is kept in used. Apart from this, S.I.M is the abbreviation for "Steadiness & Innovation in Motion Control" which well-describes the primary motto of SUNG-IL MACHINERY.



## Company History

### 1991 ~ 2010

1991	03	Business founded (Sung-il Machinery Co.,)
1993	07	Started mass production of Micro couplings
2005	12	ISO 9001 achieved
	06	Launched Support unit for ball screw product line
2006	12	“INNO-BIZ” authorized (SME)
	12	Awarded a prize for : Coupling SFC / SCJ series venture design (KIDP)
	03	Signed on the academic-industrial cooperation agreement (Univ. of SeoulTech – dept. Mechanical design automation)
2007	04	“Parts specialized company” authorized (MoTIE)
	10	Awarded a prize for : Development of excellent capital goods (MoTIE)
	12	Awarded a prize for : Coupling SHD series venture design (KIDP)
	02	Converted to a corporation (Sung-il Machinery Co., Ltd.)
2008	03	“Export-oriented Company” authorized (SME)
	08	Opened the R&D center

### 2011 ~ 2014

	02	Launched A.P Lock line
2011	06	Awarded a prize for : local economy growth (Seoul City Council)
	09	Awarded a prize for : excellent capital goods (President)
	10	Awarded a prize : gold-badge (Korea Redcross)
	03	Separate relocation of the Sales office
	03	Awarded a prize : honor-badge (Korea Redcross)
2012	08	Chinese branch established (Sung-il Machinery (WUXI) Co., Ltd.)
	09	Awarded a prize for : Technology innovation (Prime minister)
	11	Signed on the academic-industrial cooperation agreement (Univ. of SeoulTech – dept. Automobile engineering)
	02	Awarded a prize for : exemplary taxpayer (MoSF)
	06	Standardized Connecting shaft product line
2013	09	Japanese branch established (SI-Central Co., Ltd.)
	09	“Promising Export Firm ” authorized (SME)
	10	“Great workplace” authorized (SME)
2014	04	Awarded a grand prize for : Commerce & Industry in Yangchen-gu area (Kocham)
	10	Awarded a prize for : Government R&D assignment (Seoul City Council)

### 2015 ~ Present

	05	CEO appointed as one of Korea New Brain leaders (called Sinzisikin)
2015	08	CEO appointed as the Korea Master Technicians of the month (MoEL)
	09	ISO 14001 achieved
2016	09	CEO appointed as one of Korea Master Hand for Machining assembly (MoEL)
	11	CEO appointed as one of Machinery Technician of the year (KOAMI)
2017	03	“Small Giant Company” authorized (SME)
	09	“Hi-Seoul Brand” authorized (Seoul City Council)
2018	01	“Small Giant Company–young man friendly” authorized [MoEL]
	09	Seoul’s Small & Giant Company- Improved Work Environment [Seoul City Council]
2019	07	Relocation of business premises by combining manufacturing and sales offices (in Incheon city)
	07	Machine Robot Industry Development Achievement Award (MoTIE)
2020	07	Signed a work-study parallel system agreement (Bupyeong Industrial High School)
	11	Selected as “Promising Company” (Incheon City Council)
	12	Selected as the best work environment Ppuri company (Incheon City Council)
2022	07	Job Creation Enterprise (Incheon)
	11	World-Class Product – authorized [High Precision Shaft Coupling]
2023	10	Silver Tower Medal (The Order of Industrial Service Merit)
	12	Small and Medium Enterprise Success Award – 1st Place (Incheon City Council)
2025	10	Samsung Affiliate SEMES Supplier Quality Assurance (SSQ) Certification

# GLOBAL NETWORK



Branches

Global Sales Territory

## Certificates



ISO 9001



ISO 14001



SSQ



Small & Giant Company (RE)



Venture Business

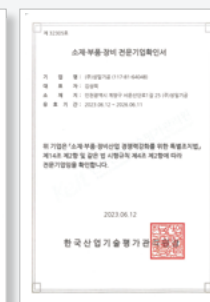

Parts specialized Firm

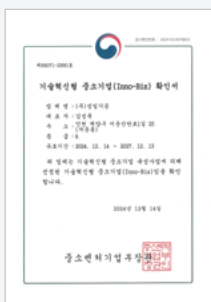

INNO-BIZ

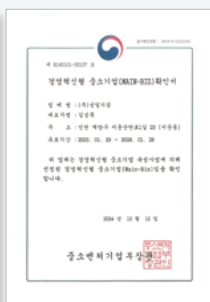

MAIN-BIZ



World-Class Product



Promising Export Firm

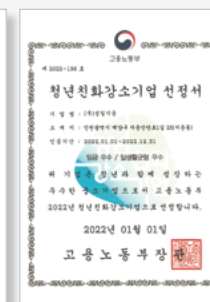

Small & Giant Company - Young-man friendly



# ONE STEP CLOSER TO THE CUSTOMER SIDE



Global Sales Territory

CHN	JPN	SGP	IDN	TWN	MYS	THA	IND
VNM	HKG	TUR	IRN	ISR	JOR	OMN	EGY
DEU	ITA	ESP	RUS	SWE	FIN	GBR	POL
BEL	SWZ	CZE	EST	HUN	MDA	SRB	SVK
UKR	ROU	USA	MEX	ARG	NZL	AUS	

## Awards



Korea Master Hand



Excellent Capital Goods (President)



Technology Innovation (Prime minister)



Machinery & Robotic Industry Innovation (MoTIE)

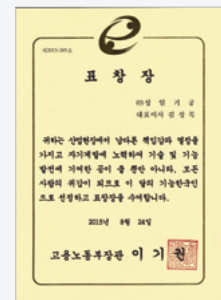

Korea Master Technicians of the month (MoEL)



Silver Tower Medal

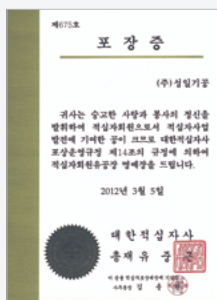

Honor-Badge (Korea Red-cross)



Exemplary Taxpayer (MoSF)



Government R&D Assignment (Seoul City Council)



Job Creation Enterprise (Incheon)

# Environmental Compliance

## ROHS / REACH CONFORMITY

- ▶ Sung-il Machinery develops and manufactures products which only conform to non-hazardous/ environmental regulations.
- ▶ Please refer to the following table for the specific list of hazardous materials. In order to receive the copy of the certificates, please ask our Customer Service team.
- ▶ For more details, please refer to the below.

### RoHS & RoHS2

Hazardous Materials	Concentration Limits (Critical Value)	RoHS1	RoHS2
Lead (Pb)	0.1wt% (1,000ppm)		
Mercury (Hg)	0.1wt% (1,000ppm)		
Cadmium (Cd)	0.01wt% (100ppm)		
Hexavalent Chromium (Cr)	0.1wt% (1,000ppm)		
Polybrominated Biphenyl (PBB)	0.1wt% (1,000ppm)		
Polybrominated Diphenyl (PBDEs)	0.1wt% (1,000ppm)		
Di-EthylHexyl Phthalate(DEHP)	0.1wt% (1,000ppm)		
Butyl Benzyl Phthalate(BBP)	0.1wt%(1,000ppm)		
Dibutyl Phthalate(DBP)	0.1wt% (1,000ppm)		
Diisobutyl Phthalate(DIBP)	0.1wt% (1,000ppm)		

No.	RoHS Impacted & Exempted Categories	RoHS1	RoHS2
1	Large household appliances: refrigerators, washers, stoves, air conditioners		
2	Small household appliances: vacuum cleaners, hair dryers, coffee makers, irons		
3	Computing & communications equipment: computers, printers, copiers, phones		
4	Consumer electronics: TVs, DVD players, stereos, video cameras		
5	Lighting: lamps, lighting fixtures, light bulbs		
6	Power tools: drills, saws, nail guns, sprayers, lathes, trimmers, blowers		
7	Toys and sports equipment: videogames, electric trains, treadmills		
8	Medical devices and equipment		
9	Control and monitoring equipment		
10	Automatic dispensers: vending machines, ATM machines		
11	All other electronic and electrical equipment (EEE) not covered under the other categories		

- We, Sung-il Machinery declare the products listed in the following page (Applied Items) meet EU DIRECTIVE 2011/65/EU and its amendments DIRECTIVE EU 2015/863 of 31 March 2015 restricting the use of certain hazardous substances in electrical and electronic equipment (ROHS)
- Please contact Sung-il Customer Service team if you need RoHS test reports for each products.

### Certification Mark(Logo)



- Please refer to upper right-side on each product description pages to find the certification logo of RoHS and REACH.
- RoHS logo will not be shown as RoHS2 covers all the ranges of RoHS categories.



## REACH (Registration, Evaluation, Authorization and Restriction of Chemicals)

- REACH is a regulation of the European Union, adopted to improve the protection of human health and the environment from the risks that can be posed by chemicals, while enhancing the competitiveness of the EU chemicals industry. It also promotes alternative methods for the hazard assessment of substances in order to reduce the number of tests on animals.
- Registration is the process of identifying substances that are produced or used in the EU. It applies to substances directly as well as substances in mixtures and in articles (parts). For substances in articles, a registration must be submitted if: The substance is produced or imported at a weight greater than 1 ton per year AND has a mixture or concentration greater than 0.1% by weight AND meets requirements of Article 57.
- Sung-il Machinery has completed the SVHC evaluation on all the coupling products based on 2012/12 standard. If it is requested to conduct any additional SVHC evaluation, please feel free to contact Sung-il Customer Service team.

## RoHS2 & REACH Applied items

### Coupling

→ SHR, SD, SAD, SHD, SJC, SOH, SRB, SRG, SCJ, SFC, SCD series

### Connecting Shaft

→ SJCL, SHDL series

### Safety Coupling

→ STL, STL-F series

### Timing Pulley

→ SATP series

### A.P. Lock (Keyless Bushing)

→ SAPL, SAPA, SAPC series

### Support Unit for Ball Screw

→ EK, EF, BK, BF, AK, AF, FK, FF, CK, CF, WBK, SWBK, HBK, ET, RN, ZN, HLRN, C-SBU, O-SBU, M-SBU, E-SBU, S-SBU, SBS, SBD series

## Declaration

You can download the self-declaration copies from our website or by scanning the QR codes below. Please contact Sung-il Customer Service team for further assistance.



RoHS2



REACH

# CONTENTS

## 01 Coupling

12 ~ 125p



## 03 Safety Coupling

134 ~ 141p



## 05 A.P. Lock (Keyless Bushing)

194 ~ 229p

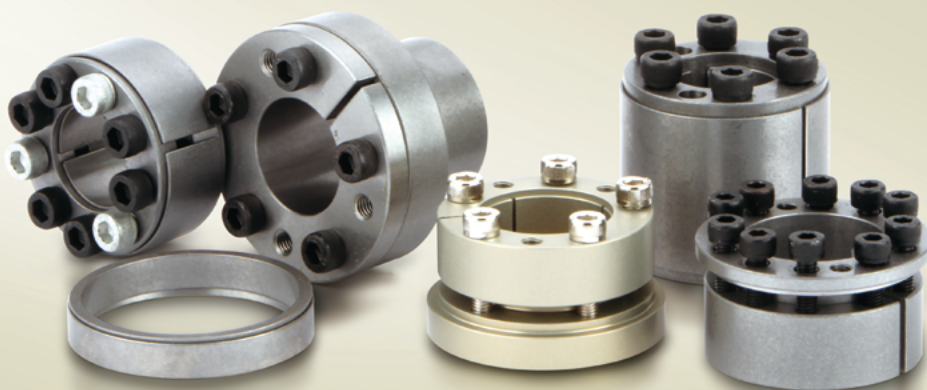

## 02 Connecting Shaft

126 ~ 133p

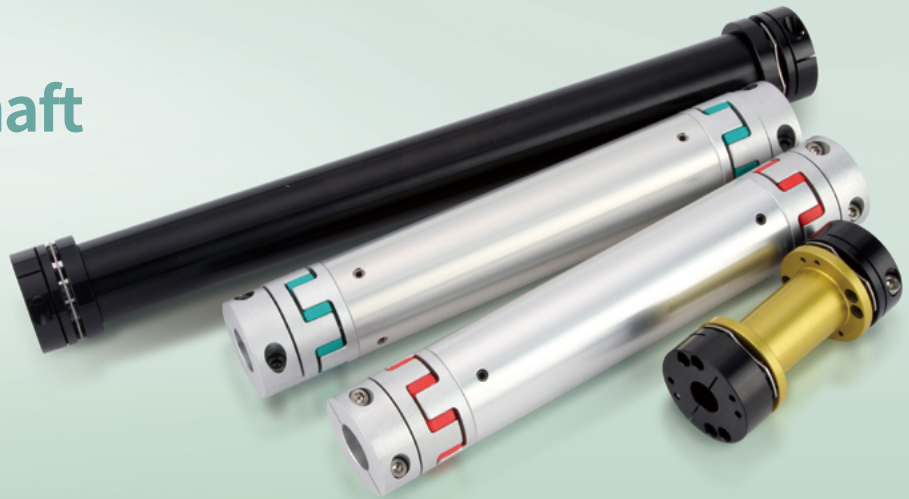

## 04 Timing Pulley

142 ~ 193p



## 06 Support Unit for Ball Screw

230 ~ 283p



# COUPLING

## Overview

Index (Coupling)	14~15p
Why Couplings?	16p
Product Features by Type	17p
Clamping Methods	18p
Selection Guide	19p
Installation Guide	20~21p
Customer-friendly Services	22~24p
- Keyway on Coupling Hubs	22p
- Non-standard ID Re-boring	22p
- Additional Tapped-holes	23p
- Parts with Alternative Material Options	23p
- Balancing Correction	24p
- Made-To-Order Process	24p

## Dimensions / Performance

SHR Series [High performance Rubber]	25~28p
SD Series [Disk]	29~48p
SAD Series [Advanced Disk]	49~53p
SHD Series [High Torque Disk]	54~64p
SCD Series [Concentricity Disk]	65~69p
SJC Series [Jaw]	70~85p
SOH Series [Oldham]	86~97p
SRB Series [Radial Beam]	98~106p
SRG Series [Rigid]	107~115p
SCJ Series [Cross Joint]	116~118p
SFC Series [Urethane Flexible]	119~120p
SK Series [Schmidt]	121~125p





# INDEX (COUPLING)

SHR Series  
SD Series  
SAD Series

Series	SHR		SD	
Model	SHR		SDS	
Material(Hub)	High Strength Aluminum Alloy	High Strength Aluminum Alloy	High Strength Aluminum Alloy	High Strength Aluminum Alloy
Clamping Methods	Side-clamp		Side-clamp	Set-screw
Shape				
Page	27p		31p	

SHD Series  
SCD Series

Series	SHD		
Model	SHDS		
Material(Hub)	Ultra High Strength Aluminum Alloy / Steel (Big size)		Ultra High Strength Aluminum Alloy
Clamping Methods	Set-screw	Side-clamp	Taper-ring
Shape			
Page	56p	57p	59p

SJC Series  
SOH Series

Series	SJC			
Model	SJC		SJCM(Space-saving)	SJC-T
Material(Hub)	High Strength Aluminum Alloy	High Strength Aluminum Alloy / Steel (Big size)	High Strength Aluminum Alloy	High Strength Aluminum Alloy
Clamping Methods	Set-screw	Side-clamp	Side-clamp	Taper-ring
Shape				
Page	74,75p	76,77p	79p	81p

SOH Series  
SRB Series

Series	SOH		SRB	
Model	SOHMP	SOHSV	SRB	
Material(Hub)	High Strength Aluminum Alloy	Stainless Steel	Ultra High Strength Aluminum Alloy	
Clamping Methods	Side-clamp	Side-clamp	Set-screw	Side-clamp
Shape				
Page	95p	97p	99p	99p

SRG Series  
SCJ Series  
SFC Series  
SK Series

Series	SRG				
Model	SRG		SRGL	SRGS	
Material(Hub)	High Strength Aluminum Alloy		High Strength Aluminum Alloy	Stainless Steel	
Clamping Methods	Set-screw	Side-clamp	Side-clamp	Set-screw	Side-clamp
Shape					
Page	108p	109p	109p	112p	113p

			SAD	
	SDSS	SDWS	SADS	SADW
High Strength Aluminum Alloy Side-clamp	Stainless Steel Side-clamp	Stainless Steel Side-clamp	High Strength Aluminum Alloy Side-clamp	
				
38, 41p	44p	47p	51p	53p
			SCD	
SHDW			SCDS	SCDW
Ultra High Strength Aluminum Alloy / Steel (Big size) Set-screw		Ultra High Strength Aluminum Alloy Taper-ring	Steel Side-clamp	
				
61p	62p	64p	67p	69p
			SOH	
SJC-I	SJCP-T	SOH		SOHM(Space-saving)
High Strength Aluminum Alloy Shaft-insertion	Steel Taper-ring	High Strength Aluminum Alloy Set-screw	High Strength Aluminum Alloy Side-clamp	High Strength Aluminum Alloy Side-clamp
				
83p	85p	87p	90p	92p
SRB				
SRBM(Space-saving)		SRBS		SRBMS(Space-saving)
Ultra High Strength Aluminum Alloy Set-screw		Stainless Steel Side-clamp		Stainless Steel Side-clamp
				
101p	101p	104p	104p	106p
		SCJ	SFC	SK
SRGP	SCJ		SFC	SK
Steel Taper-ring	High Strength Aluminum Alloy Set-screw		Steel Set-screw	Steel -
				
115p	117p	118p	120p	124p

# Why Couplings?

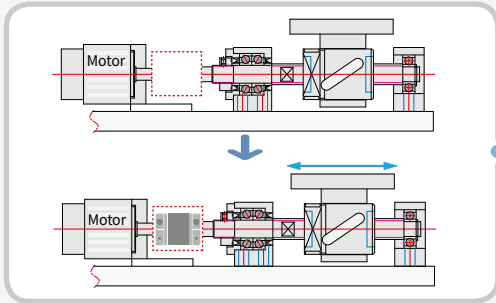

## 1. Power Transmission

The core role of a coupling is to transmit motion (Torque) from “Driving shaft” to “Driven shaft”

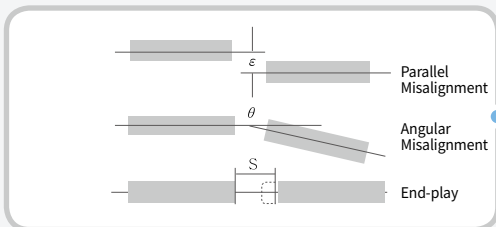

## 2. Absorption of Misalignment

Due to such mechanical tolerance, precision grade and proficiency, misalignment occurs between driving and driven parts most of the cases. This misalignment is classified as angular, parallel and end-play way and it brings excessive load onto mechanical parts which is quite sensitive to vibration and noise. Sung-il couplings (except Rigid type- SRG series) can absorb this type of misalignment. Please refer to “Dimensions / Performance” pages for more details by each coupling types.

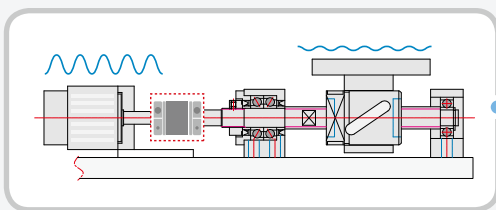

## 3. Absorption of Impact/Vibration/Noise

Sometimes, there is either vibration or impact on the application e.g. motor, reducer or ball screw. If they are passed onto the application directly, the entire application including expensive devices will need repairing. Sung-il Couplings (except Rigid type –SRG series) absorb these kinds of external factors in an effective way. Particularly the models with plastic material spacer between hubs (SHR, SJC, SOH series etc.) perform better in terms of this function.

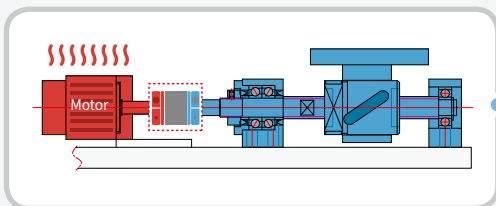

## 4. Insulation of Heat and Electric current

If a motor is used for a long time, heat and electric current may get occurred. If the heat is also transmitted to the driven part, there is possibility of expansion of connected parts which will reduce the precision of application. Sung-il Couplings can protect the application and keep its performance stable in an effective way through insulating heat and electric current.

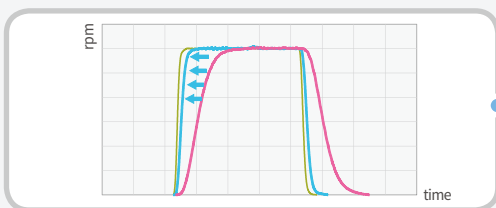











## 5. Performance Improvement

With SHR series (High performance Rubber type), the gain value on the motor could be set higher thanks to superior damping decrease. This feature allows the stabilization time to be reduced and make whole efficiency higher.



# Characteristics by Type

Sung-il Machinery manufactures various model types of coupling and can provide optimal selection options according to customer's needs. You can select a coupling referring to the below table, which briefly explains about each model's characteristics by some criteria. However, it is important to check specific "Dimensions / Performance" details in each Coupling pages as the below table is only a simplified guideline.

Model	Shape	Backlash free	High Torque	Torsional Stiffness	Vibration Absorption	Misalignment Absorption	Oil resistant	Electric Insulation	Applicable Motors			
									Servo	Stepping	Encoder	General
SHR		☆	☆	○	☆	○	△		☆	☆	○	
		SHR series is excellent for vibration absorption and helps to enhance efficiency of application allowing higher gain value on the servo motors.										
SD		☆	○	☆		○	○		○	○	○	
		SD series is excellent for absorbing misalignment by plate springs and is widely used on servo/step motors.										
SAD		☆	☆	☆		○	○		☆	☆	○	○
		SAD Series is more stiff and durable compared to similar sized general disk couplings (SD series) with the advanced structure in the plate springs. We provide SAD series in small/compact sizes.										
SHD		☆	☆	☆		○	○		○	○		○
		SHD Series is designed to transmit high torque by adopting harder material and the advanced structure in the plate springs. We provide SHD series in mid/large sizes.										
SCD		☆	☆	☆		△	○		☆			
		SCD Series is designed to be well-concentric with higher torsional stiffness by processing inner and outer diameter simultaneously, which enables users to install the coupling in a more precise way.										
SJC		○	☆	○	○	△	△	○	○	○	△	☆
		SJC series is the most excellent coupling for transmitting high torque and is durable for vibration/impact.										
SOH		△	○	△	○	☆	△	○	△	△	○	☆
		SOH series is excellent for absorption of parallel misalignment and enables reaction force on the shaft to be reduced. It is simple for self-maintenance.										
SRB		☆	△	○		○	○		○	○	○	
		SRB series is good for both angular/parallel misalignment absorption however it is relatively less-durable.										
SRG		☆	○	☆			○		○			
		SRG series is excellent to be used at highly-precise applications, however there is no ability to absorb misalignment on this product.										
SCJ		△		○	△	☆			△	△	△	
		SCJ series is excellent for absorbing both angular/parallel misalignment, and it minimizes reaction force on the shaft.										
SFC					○	☆		○			△	○
		SFC series is flexible with Urethane material and is excellent for absorbing misalignment, however it is relatively less-durable.										

※ Please refer to the meaning of symbols as below.  
 ☆: excellent / ○: good / △: medium / blank: N/A

# Clamping Methods

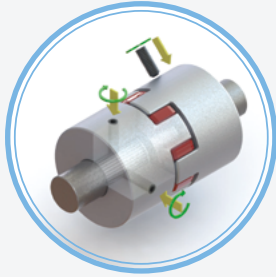

## Set-screw Type

How to work	Clamp a coupling onto a shaft only by screw's thrust, contacting screws directly to the shaft
Pros	Economical and Simple
Cons	Less clamping force The surface of shaft can be damaged due to direct contact

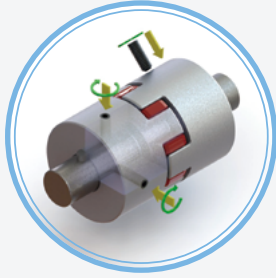

## Key & Keyway Type

How to work	Clamp a coupling onto a shaft by interlocking a key and keyway each other
Pros	Better clamping force unless the key or the coupling hub is broken. Can be used as a complementary option for Set-screw or Side-clamp methods
Cons	Keyway can be worn out easily under repeated rotation. Relatively complicated to install

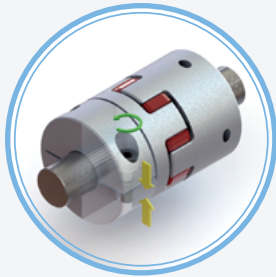

## Side-clamp Type

How to work	Clamp a coupling with fastening screws in a vertical way to the shaft and make the coupling's inner diameter contracted by the side-slits
Pros	Better clamping force than the Set-screw type Easy and simple to install
Cons	Unless the tolerances are well-managed, the clamping force is not always guaranteed

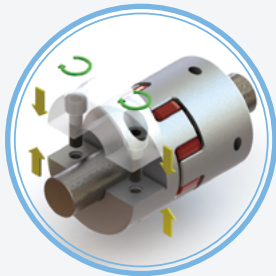

## Side-clamp Hub Split Type

How to work	A part of coupling's hub can be completely split off. (The working process is as same as the general Side-clamp Type)
Pros	No need of shifting the connected devices during maintenance. Better clamping force than the general Side-clamp Type
Cons	Higher cost due to the additional processing

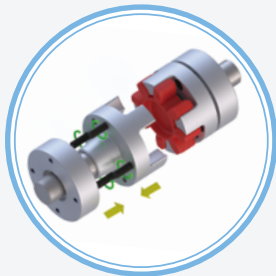

## Taper-ring Type

How to work	Clamp a coupling onto a shaft by interlocking screws on the wedge-shaped inner and outer rings
Pros	High clamping force with self-centering function The excellent structure for self-balancing feature
Cons	Relatively higher cost Relatively complicated to install

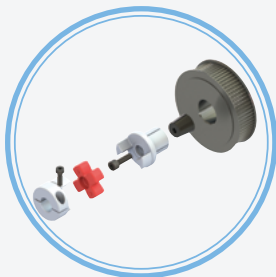

## Shaft-insertion Type

How to work	Bushing and Insert hub are tightly coupled by the thrust of fastening screws. And then the insert part gets spread outward due to the taper structure and clamped into the inner diameter on the other side.
Pros	Space-saving design Simple clamping methods by tightening a single screw
Cons	-

# Selection Guide

**STEP 1**  
Select a coupling type

A coupling type is selected mainly according to characteristic chart and types of connected motors. In case it is going to be used in a special environment e.g. vacuum, high-temperature, cleanroom facilities etc., please contact Sung-il Customer Service team in advance. As Sung-il Machinery manufactures products with various types of material, we may suggest an appropriate coupling considering the circumstance it is to be used.

**STEP 2**  
Select a coupling's outer diameter (OD) size

The coupling's outer diameter (OD) size is determined mainly by torque. The rated torque of a coupling has to be higher than the operation torque of a motor. The safety factor could be differently calculated by case/customer. The operation torque information can be easily found on the motor's specification.

In case the operation torque should be calculated with operational P(Power Output) and N(rpm) values, please refer to the below formula.

$$T = 9550 \times \frac{P(\text{kW})}{N(\text{rpm})}$$

In case a coupling includes plastic sort material (SHR, SJC, SOH, SFC series), the rated torque of a coupling has to be modified according to temperature ranges. Please refer to the below table.

Temperature range	-20 °C ~ 30 °C	30 °C ~ 40 °C	40 °C ~ 60 °C	60 °C ~ 120 °C
Correction factor	1.0	0.8	0.7	0.55

**STEP 3**  
Check the max. inner diameter (ID)

Both inner diameters (ID) of driving and driven shafts have to be within the range of maximum ID of a coupling. If either ID of driving shaft or driven shaft is out of range from the selected coupling, the coupling has to be sized up. For instance, SDS-19C is selected at the Step 2, however the ID of shaft is 8mm, it is out of range as the max. ID on SDS-19C is 6mm. In this case, the coupling should be one sized up to SDS-22C.

Model	Standard Inner Diameter (d <sub>1</sub> , d <sub>2</sub> ) (mm)															
	3	4	4.5	5	6	6.35	7	8	9	9.525	10	11	12	12.7	14	15
SDS-16C	●	●	●	●												
SDS-19C	●	●	●	●	●											
SDS-22C	●	●	●	●	●	●	●	●	★	★						
SDS-26C		●	●	●	●	●	●	●	●	●	●	●	●	●	●	●

However, the coupling size cannot be adjusted due to space matter, please check with us for the alternative option of non-standard ID supply by re-boring ID sizes over the range. In this inevitable case, re-boring inner diameters itself may not be so difficult, however there is high possibility that the durability of product drops down to a greater extent thus, this process is only implemented under customer's full responsibility. Besides, the lead-time could be somewhat longer than usual.

**STEP 4**  
Check slip torque

### Slip Torque of selected ID (shaft) > Operating torque

Please compare slip torque values of each selected inner diameters with the operational torque referring to the information in the "Dimensions / Performance" pages. (See the example table below.)

Let's suppose the coupling SDS-22C-4mmx8mm is selected through step.1 to step.3. According to the slip torque table, the max. torque of SDS-22C is 2.2N·m. The slip torque at the ID 8mm is higher than 2.2N·m (The specific slip torque values higher than the max. torque of couplings are not stated in the table.) and at the ID 4mm 1.4N·m respectively.

Since the slip torque at the ID 8mm is higher than max. torque of the coupling, there is no further concern about slips at the ID 8mm. However, the slip torque at the ID 4mm must be compared with the operating torque, concerning its slip torque(1.4N·m) is lower than the max. torque of the coupling.

In any case the slip torque is lower than the operating torque like this, a larger sized coupling must be selected or an additional supplement e.g. key/keyway has to be along with for safer use.

The below slip torque values may be subject to change according to different testing conditions. (e.g. shaft tolerance, surface roughness, surface treatment or acceleration/deceleration of driving shafts)

Model	Max. Torque(N·m)	Slip Torque (N·m) by Inner Diameter (d <sub>1</sub> , d <sub>2</sub> )																	
		3	4	4.5	5	6	6.35	7	8	9	9.525	10	11	12	12.7	14	15	15.875	16
SD□□-16C	1	0.6	0.7	0.8	0.9														
SD□□-19C	1.8	1	1.3	1.4	1.5	1.7													
SD□□-22C	2.2	1.1	1.4	1.5	1.7	2	2.1												
SD□□-26C	3		2	2	2.9														

**STEP 5**  
Check other points

Clamping Methods, Permissible misalignment, Torsional stiffness, Max. rpm, etc.

# Installation Guide

## Suggested Shaft-insertion Depth

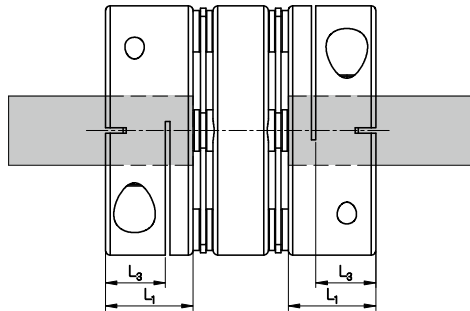

Side-clamp

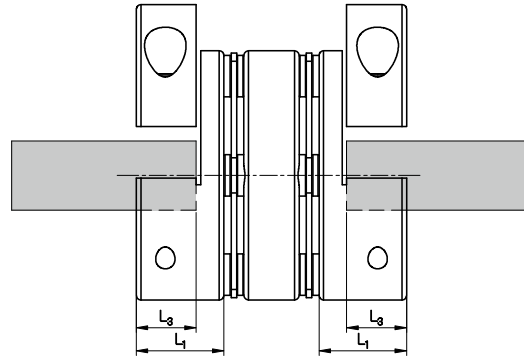

Side-clamp Split

- The most ideal length of shaft-insertion is up to ' $L_1$ ' on each dimension pages. (For side-clamp split type, it is up to ' $L_3$ !')
- If a shaft is not inserted deep enough into the coupling, it could make the shaft slipped out or make the coupling hub broken.
- If a shaft is inserted into the coupling too deeply, the coupling could be broken easily due to the interference between the shaft and coupling's inner part or interference between both shafts.

## Precautions for Screw tightening

After inserting the shaft, when tightening the coupling screws, be sure to refer to the fastening torque values in the product specification table and tighten accordingly.

- If the fastening torque of the screw is low, the clamping force of the coupling may not be sufficiently exerted and slip may occur.
- If the fastening torque of the screw is excessive, the bottom of the screw head may sink, depending on the material of the internal thread (coupling). This could lead to a loss of tension in the fastening screws and a decrease in clamping force.
- Moreover, exceeding the yield point can cause a rapid increase in elongation rate, resulting in permanent deformation of the screw, and in severe cases, it may lead to breakage.
- Always tighten the fastening bolts after inserting the shaft. Fastening the screw without inserting the shaft can cause deformation of the coupling hub.

Model	Size ( $\pm 0.3\text{mm}$ )					Screw		Rated Torque (N·m)	Max. Torque (N·m)	Max. rpm ( $\text{min}^{-1}$ )	Moment of Inertia ( $\text{kg}\cdot\text{m}^2$ )	Static Torsional Stiffness (N·m/rad)	Mass (g)	Permissible Misalignment			Side-clamp Hub Split (W)
	D	L	$L_1$	$L_3$	F	Size	Fastening Torque (N·m)							Angular ( $^\circ$ )	Parallel (mm)	End-play (mm)	
SHR-14C	13.8	22.4	6.7	4	2.1	M1.6	0.3	1	2	42,000	$1.6 \times 10^{-7}$	41	6	1.5	0.15	$\pm 0.2$	○
SHR-18C	17.8	25.5	8	5	2.7	M2	0.6	1.9	3.8	33,000	$4.9 \times 10^{-7}$	84	11	1.5	0.15	$\pm 0.2$	○
SHR-24C	23.8	31.2	9.6	6.3	3.1	M2.6	1.1	3.5	7	25,000	$1.9 \times 10^{-6}$	132	22	1.5	0.15	$\pm 0.2$	○
SHR-29C	28.8	35	11	7.2	3.7	M3	1.8	5.7	11.4	21,000	$4.4 \times 10^{-6}$	209	34	1.5	0.2	$\pm 0.3$	○
SHR-33C	32.8	37	12	7.3	3.8	M3	1.8	7	14	18,000	$8.3 \times 10^{-6}$	370	51	1.5	0.2	$\pm 0.3$	○

# Customer-friendly Services

## Fastening D-cut shaped shaft into a Coupling (Only Side-clamp Type)

- Technically, the adequate clamping force can be guaranteed only with round-shaped shaft. However, in case D-cut shaped shaft has to be used, please follow the below instructions.

### Case 1: With side-slits

- As shown in the below example, in a side-slit coupling structure there are normally 2 parts, side-slit (white area) and the rest (blue area). The mechanism of contraction differs by the location of side-slit and shape of each couplings. If a D-cut shaped shaft is inserted into a coupling, it should be located in the blue area, which is not affected by contraction when fastening screws. Please be aware that the clamping force may become lower under an inappropriate shaft fastening.

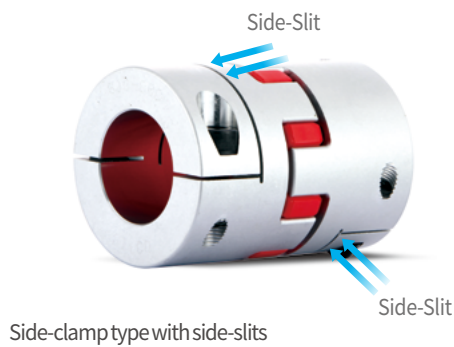

#### Examples of D-cut shaped shaft-insertion

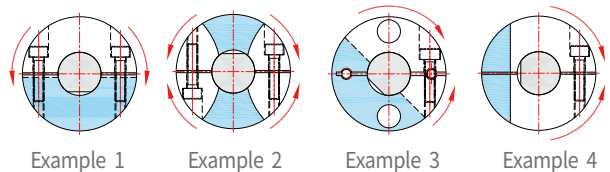

### Case 2: Without side-slits

- There is no side-slits on space-saving side-clamp couplings e.g. SJCM, SOHM etc. In this case, the D-cut shaft should be located right opposite to contraction (screw-fastening) side.



#### Examples of D-cut shaped shaft-insertion

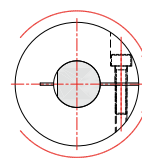

# Customer-friendly Services

## Keyway on Coupling Hubs

Shaft(Bore) Diameter Ød1 / Ød2	Keyway Dimension					Nominal Size	
	b(mm)			t(mm)		(b x h)	
Over ~ To	Mark Size	No Mark Tol. (E9)	H Tol. (H9)	J Tol. (Js9)	Size	Tolerance	
Ø6(over) ~ Ø8	2	+0.039	+0.025	±0.0125	1	+0.1 0	2×2
Ø8 ~ Ø10	3	+0.014	0		1.4		3×3
Ø10 ~ Ø12	4	+0.05 +0.02	+0.03 0	±0.015	1.8		4×4
Ø12 ~ Ø17	5				2.3		5×5
Ø17 ~ Ø22	6				2.8		6×6
Ø22 ~ Ø30	8	+0.061	+0.036	±0.018	3.3	8×7	
Ø30 ~ Ø38	10	+0.025	0			10×8	
Ø38 ~ Ø44	12			12×8			
Ø44 ~ Ø50	14	+0.075 +0.032	+0.043 0	±0.0215	3.8	+0.2 0	14×9
Ø50 ~ Ø58	16				4.3		16×10
Ø58 ~ Ø65	18			4.4	18×11		
Ø65 ~ Ø75	20	+0.092	+0.052	±0.026	4.9		20×12
Ø75 ~ Ø85	22	+0.04	0		5.4		22×14

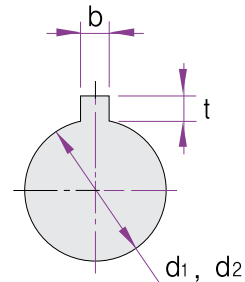

- The location of keyway on a coupling hub is determined by the standard product design of Sung-il Machinery. If you need a keyway in a different location, please discuss with our Customer Support team in advance.
- The standard keyway tolerance is E9, which is the most suitable option in terms of the assembly convenience.
- If a specific keyway tolerance is required for a special case, please choose the code from the table and mention it on the PO. (Please refer to "How to order" below)
- Keyways can be applied on the following clamping methods of couplings. (Side-clamp, Side-clamp Hub Split and Set-screw)
  - exception 1: SFC series – Structurally impossible to have keyway
  - exception 2: SAD series – Due to structural interference (increased number of assembly holes), we ask you to check with our customer support team for availability in advance.

### ※ HOW TO ORDER

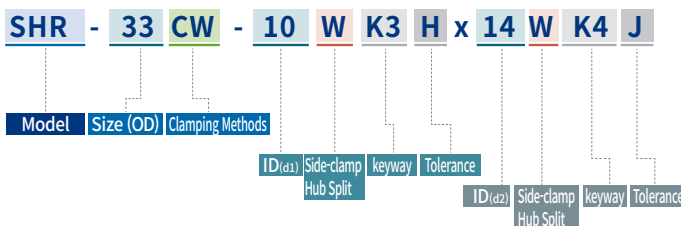

- Please indicate K(b=width) next to ID(d1)
- In general, t(depth) of a keyway is automatically determined by b(width). However if a keyway with special dimension is required, please discuss with our Customer Support team in advance. (For example, K3 will be provided with b(3mm) & t(1.4mm) unless there is a special remark.)
- Keyway Tolerance

Mark	No Mark	H	J
Tolerance	E9	H9	Js9

## Non-standard Inner Diameter (ID) Available

### Case 1 : Non-standard Inner Diameter(ID) Re-boring : Between standard min. ID and standard max. ID

Model	Standard Inner Diameter (d <sub>1</sub> , d <sub>2</sub> ) (mm)																						
	10	11	12	12.7	14	15	15.875	16	17	18	19	20	22	24	25	26	28	30	32	35	40	45	50
SDCS-54C	●	●	●	●	●	●	●	●	●	●	●	●	●	●	●								
SDCS-64C			●	●	●	●	●	●	●	●	●	●	●	●	●	★	★	★	★				
SDS-80C						●	●	●	●	●	●	●	●	●	●	●	●	●	●	●			

- Any Integer Inner Diameter(ID) between standard min. ID and standard max. ID could be provided even they are not indicated on the standard ID table.
  - (※ Exception Item: SDS-12C, SDWA-12C, SOH-6, SOH-8, SOH-10, SOH-12, SRB-8, all sizes of SFC)
- For example, ID:Ø27 on SDCS-64C is available as Ø27 is within the range between Ø12(min.) and Ø32(max.)

### Case 2 : Non-standard Inner Diameter(ID) Re-boring : Smaller than standard min.ID and bigger than standard max.ID

We Sung-il team will always try our best to supply goods at the customer's best convenience.

- Please firstly ask our Customer Support team to check whether it is structurally possible.
- In the case of non-standard ID bigger than max.ID, please be aware that durability would get decreased from the ordinary performance of coupling.

### Case 3 : Special tolerance for Inner Diameter

- Please ask our Customer Support team to check if you require a special(customized) bore tolerance for coupling.

# Customer-friendly Services

## Additional Tapped-holes

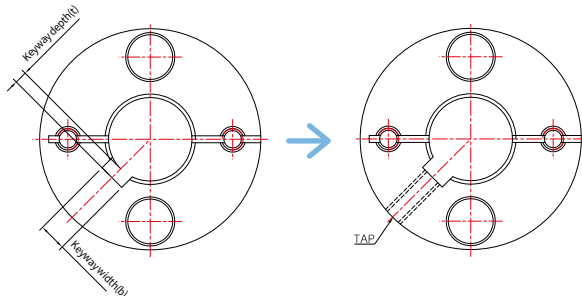

- Sung-il Machinery provides additional tapped holes on coupling hubs upon the request.
- This additional tapped holes are usually requested when there are keyway used on a coupling.
- For this service, please contact Sung-il Customer Service team prior to firm order placement, in order to discuss accurate location of the tapped hole and the screw thread.

## Parts with Alternative Material Options

- Sung-il Machinery provides alternative material options for Coupling parts.  
(FAS screws: to fasten a shaft into a coupling & ASS screws: to assemble a coupling itself)
  - 1) Stainless Steel (STS304)
  - 2) SCM435 with surface treatment -Electroless Nickel Plating
- Caution: Slip torque would become lower if the body material or surface treatment of screws are changed from the standard (SCM435, Black Oxide) version.

### CASE 1

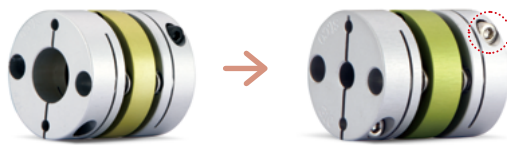

Case 1 : Stainless Steel

SDWA - 26C - 6 x 8 - SUS/ASS

Standard: SCM435 (Black Oxide)  
Option(1): STS304 (Stainless Steel)

Please add the additional coding  
"SUS/ASS" next to the model no.

### CASE 2



Case 2 : Surface treatment - Electroless Nickel Plating

SRG - 25C - 6 x 8 - NI/ASS

Standard: SCM435 (Black Oxide)  
Option(2): SCM435 (with surface treatment -Electroless Nickel Plating)

Please add the additional coding  
"NI/ASS" next to the model no.

## ※ Standard Product Models with the Parts made of Stainless Steel or Electroless Nickel Plating

Model	Size (OD)	Body Material	Surface Treatment	Screws
SRBS	All Sizes	Stainless Steel	-	STS304
SRBMS	All Sizes	Stainless Steel	-	STS304
SDSS	All Sizes	Stainless Steel	Electropolishing	STS304
SDWS	All Sizes	Stainless Steel	Electropolishing	STS304
SHDS-NI	126, 144	Steel	Electroless Nickel Plating	SCM435 (Electroless Nickel Plating)
SHDW-NI	126, 144	Steel	Electroless Nickel Plating	SCM435 (Electroless Nickel Plating)
SJC	120, 135, 160	Steel	Electroless Nickel Plating	SCM435 (Electroless Nickel Plating)
SOHMP	All Sizes	High Strength Aluminum Alloy	-	STS304
SOHSV	All Sizes	Stainless Steel	Electropolishing	STS304
SRGS	All Sizes	Stainless Steel	-	STS304

# Customer-friendly Services

## Balancing Correction

- Balancing is a very important factor of a coupling which is connected to high-spindling driving part e.g. machine tools. If it is unbalanced, vibration and noise could be brought to a great extent, resulting in reduced performance in the whole applications.
- Sung-il Machinery can conduct any sort of customized designs utilizing autonomous test machines. If a higher level of balancing is requested on our couplings, we could implement with the following steps.

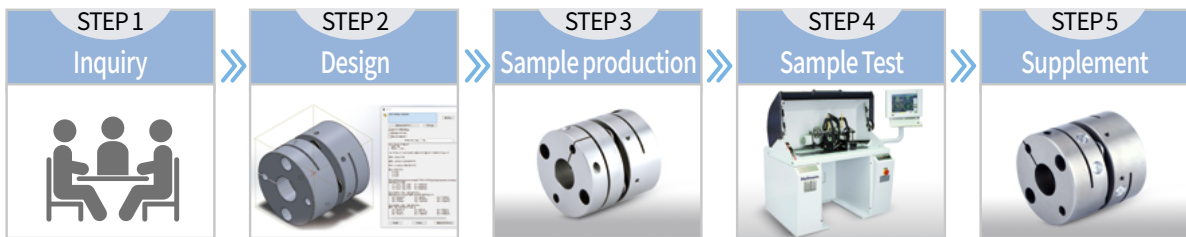

## Made-To-Order Process

Sung-il Machinery can conduct Made-To-Order processes (customization) upon our customers' requests.

### Various Bore Area Shapes and Attachment Design



- D-Cuts, Rectangular Bores, Multiple keyways
- Spline cutting and any other requested bore designs

### Various Materials/Surface Treatment Options



- Non-standard Metal or Plastic Materials
- Various kinds of Anodizing, Teflon Coating, Any custom Surface Treatment by request etc.

### Length Adjustment



- Non-standard length adjustment

### Customized Shaping



- Completely new shape designs according to customer's applications

※ Please do not hesitate to contact us even for other Made-To-Order cases apart from the above 4 categories.  
 ※ Please make sure we discuss the specific design prior to firm order placement.

# SHR SERIES



## High Performance Rubber Coupling

### Higher Efficiency through Higher Gain Allowance

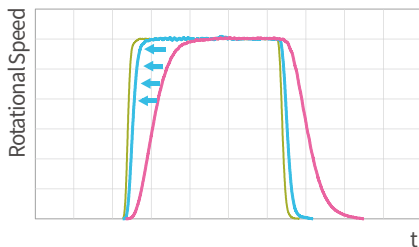

- Gain value is an indicator that shows how accurately it operates according to the command on servo motors.
- Higher gain brings higher responsivity, at the same time it also results in hunting and resonance onto application.
- The anti-vibration rubber (HNBR) is excellent for damping and has higher dynamic stiffness, so it enables to reduce side-effects under the increased gain value.

When SHR series is used, the gain value can be increased higher than SD series (Disk type) as there is relatively bigger gain margin on Bode Plot -180deg.

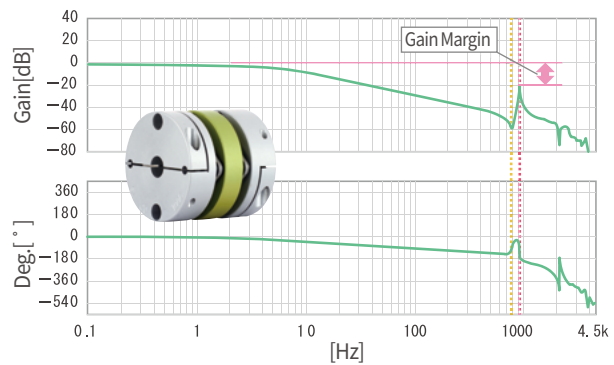
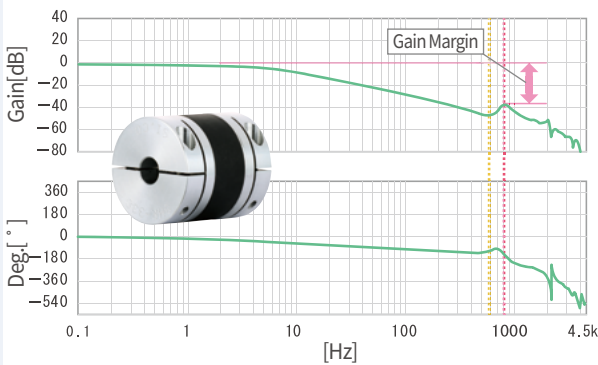

SHR series has the excellent function of damping so it allows to minimize stabilization time of the application.

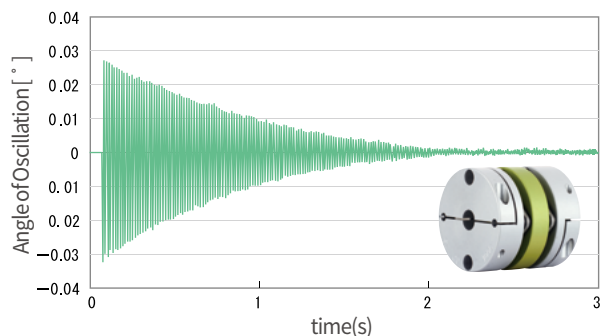
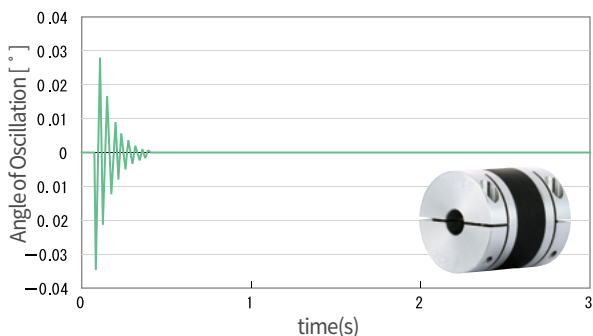

# SHR SERIES

## High Performance Rubber Coupling

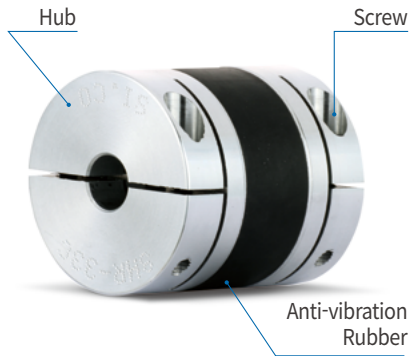

### Structure and Material

Structure	Material	Surface Treatment
Hub	High Strength Aluminum Alloy	-
Anti-vibration Rubber	HNBR	-
Screw	SCM435	Black Oxide

### Product Features & Application

**Product Features** : Great for Anti-vibration & increasing gain on Servo motor → High Productivity

Backlash free		☆
High Torque (Durability)		☆
Torsional Stiffness		○
Vibration Absorption		☆
Misalignment Absorption		○
Oil Resistance		△
Applicable Motors	Servo	☆
	Stepping	☆
	Encoder	○
	General	-
Permissible Temperature		-20°C ~ 80°C

**Application** : Semi-conductor manufacturing machine, SMT, Cartesian Robot, UVW Stage

### Chemical Resistance

For your reference, please check whether SHR product is being used at an appropriate environment, referring to the below table for chemical resistance of HNBR material.

Weather-resistance, Ozone-resistance	excellent
Gasoline, Diesel	allowed
Water, Alcohol	excellent
Organic Acid & Low concentration Inorganic Acid	excellent
High concentration Inorganic Acid	allowed
Strong/Weak Alkali	excellent
Benzene & Toluene	not-allowed
Ether & Ethyl Acetate	not-allowed

### Clamping Methods

Set-screw (No mark)	General	X
	With Keyway	X
Side-clamp (C)	General	○
	Hub Split	○
	With Keyway	○
Taper-ring (T)		X

### How to Order

**SHR - 33 CW - 10 W K3 x 14 W K4**

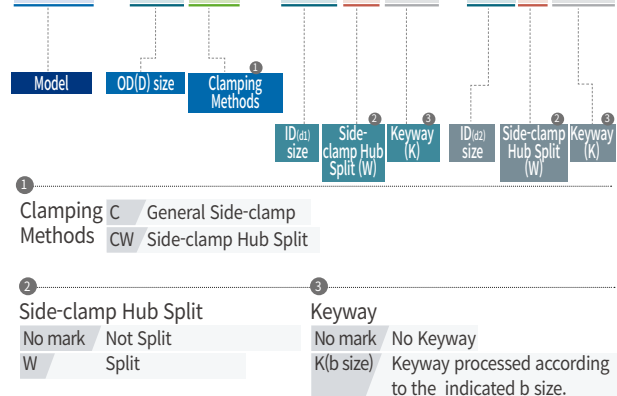

# SHR SERIES

## High Performance Rubber Coupling

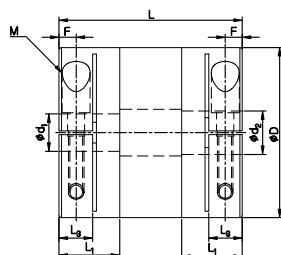

### Dimensions / Performance

Model	Size (±0.3mm)					Screw		Permissible Torque (N·m)	Max. rpm (min <sup>-1</sup> )	Moment of Inertia (kg·m <sup>2</sup> )	Static Torsional Stiffness (N·m/rad)	Mass (g)	Permissible Misalignment			Side-clamp Hub Split (W)
	D	L	L <sub>1</sub>	L <sub>3</sub>	F	Size	Fastening Torque (N·m)						Angular (°)	Parallel (mm)	End-play (mm)	
SHR-14C	13.8	22.4	6.7	4	2.1	M1.6	0.3	1	42,000	1.6×10 <sup>-7</sup>	41	6	1.5	0.15	±0.2	○
SHR-18C	17.8	25.5	8	5	2.7	M2	0.6	1.9	33,000	4.9×10 <sup>-7</sup>	84	11	1.5	0.15	±0.2	○
SHR-24C	23.8	31.2	9.6	6.3	3.1	M2.6	1.1	3.5	25,000	1.9×10 <sup>-6</sup>	132	22	1.5	0.15	±0.2	○
SHR-27C	26.8	32	10	6.6	3.3	M2.6	1.1	4	22,000	3.4×10 <sup>-6</sup>	180	31	1.5	0.15	±0.2	○
SHR-29C	28.8	35	11	7.2	3.7	M3	1.8	5.7	21,000	4.4×10 <sup>-6</sup>	209	34	1.5	0.2	±0.3	○
SHR-33C	32.8	37	12	7.3	3.8	M3	1.8	7	18,000	8.3×10 <sup>-6</sup>	370	51	1.5	0.2	±0.3	○
SHR-38C	37.8	47	15.5	8.9	4.6	M4	3.7	12	16,000	1.8×10 <sup>-5</sup>	479	78	1.5	0.2	±0.3	○
SHR-43C	42.8	48	15.5	9	4.8	M4	3.7	16	14,000	3.2×10 <sup>-5</sup>	610	115	1.5	0.2	±0.3	○
SHR-55C	54.8	59	19.5	10.8	5.5	M5	8.5	32	11,000	1.1×10 <sup>-4</sup>	1,430	250	1.5	0.2	±0.3	○
SHR-68C	67.8	75	23.5	15	7.5	M6	13	65	9,000	4.2×10 <sup>-4</sup>	7,500	470	1.5	0.2	±0.3	○

- The Moment of Inertia and Mass values are based on products with max. Inner diameter.
- Please modify Permissible Torque value with temperature correction factor when it's higher than 30°C.
- Permissible Torque is the value regarding to a coupling's self-durability and is not related to slip-torque between the coupling bore and the shaft.

### Standard Inner Diameter (ID)

Model	Standard Inner Diameter (d <sub>1</sub> , d <sub>2</sub> ) (mm)																										
	3	4	4.5	5	6	6.35	7	8	10	11	12	13	14	15	16	17	18	19	20	22	24	25	28	30	32	35	
SHR-14C	●	●	●	●	●																						
SHR-18C		●	●	●	●	●	●	●																			
SHR-24C				●	●	●	●	●	●	●	●																
SHR-27C				●	●	●	●	●	●	●	●	●	●														
SHR-29C					●	●	●	●	●	●	●	●	●	●													
SHR-33C								●	●	●	●	●	●	●	●												
SHR-38C								●	●	●	●	●	●	●	●	●	●	●	●	●							
SHR-43C									●	●	●	●	●	●	●	●	●	●	●	●	●						
SHR-55C										●	●	●	●	●	●	●	●	●	●	●	●	●	●				
SHR-68C																	●	●	●	●	●	●	●	●	●	●	●

- The recommended shaft tolerance is h7.
- Custom process (e.g. non-standard Inner diameter, special tolerance etc.) is also available upon a special request in prior to order placement.
- Keyway is available. (Optional)
- Side-clamp Hub Split is available. (Optional)

# SHR SERIES

## High Performance Rubber Coupling

### Slip Torque

- The below table shows the actual permissible torque values when the slip torque value is lower than the coupling's permissible torque value.
- If the slip torque value is lower than the coupling's permissible torque value, please check and compare between the slip torque in the below table and the operating torque value of the connected motor. It is safer to size up the coupling or use a key/keyway when the slip torque value is lower than the motor's operating torque.
- The below slip torque values may be subject to change according to different testing conditions. (e.g. shaft tolerance, surface roughness, surface treatment or acceleration/deceleration of driving shafts). On the other hand, the values could be affected when a different kind of fastening screw is used (body material or surface treatment). Therefore, we recommend you test under the same conditions before mounting.

Model	Permissible Torque (N·m)	Slip Torque (N.m) by Inner Diameter (d <sub>1</sub> , d <sub>2</sub> )																						
		3	4	4.5	5	6	6.35	7	8	10	11	12	14	15	16	17	18	19	20	22	24	25	28	30
SHR-14C	1	0.5	0.6	0.6	0.7	0.8																		
SHR-18C	1.9		1.5	1.5	1.6	1.9	2																	
SHR-24C	3.5				2.5	3	3.3	3.5																
SHR-27C	4				1.5	2.5	2.8	3	3.2															
SHR-29C	5.7					3.5	3.8	4	5															
SHR-33C	7								7															
SHR-38C	12								6.5	9	10	12												
SHR-43C	16									14	16													
SHR-55C	32																							
SHR-68C	65																54	57	65					

### Side-clamp Hub Split(W) Option is available on all sizes of SHR series

- Please refer to "HOW TO ORDER" page for more details.



### Temperature Correction Factor

- Please modify Permissible Torque value with the below temperature correction factor when it's higher than 30°C.

Ambient Temperature	Correction Factor
-20 °C ~ 30 °C	1.0
30 °C ~ 40 °C	0.8
40 °C ~ 60 °C	0.7
60 °C ~ 120 °C	0.55

# SD SERIES



## Disk Type Coupling

### Classification: SD Series

The plate springs in the middle part of SD Series transmit motion & power and absorb the misalignment. SD Series is usually adopted for high-precision applications thanks to its excellent static torsional stiffness and the backlash-free full metal structure.

Body Material	Plate-Spring Modules	Clamping Methods			
		Set-screw	Side-clamp		
High Strength Aluminum Alloy	Single Disk (SDS)				
	Double Disk (SDW, SDA)				
Stainless Steel	Single Disk (SDSS)	-	-		
	Double Disk (SDWS)	-	-		

### Single Module vs Double Module

	Single Disk	Double Disk
Plate-Spring Modules	1	2
Transmission Level of Torque (Permissible Torque)	Identical	
Static Torsional Stiffness	High	Low
Absorption of Misalignment	Low	High

- SD Series absorbs the misalignment through the plate springs in the middle part. Therefore, the double module is better at absorption of misalignment than the single module.
- On the other hand, the single module has higher stiffness and precise positioning feature as well as it saves space in terms of shorter length(L).

### Custom Service : Extra plate springs Reinforcement

- The most important part that determines the performance of SD coupling is assembly set of Plate-Springs.
- As a customized service, Sung-il Machinery provides extra quantity of plate springs added according to customer's special requests.
- However, please be aware that this process makes strength of product enhanced, at the same time it may increase reaction force on shafts and would give negative effects on the connected devices.



- Please contact Sung-il Customer Service team for more details.

# SD SERIES (SDS)

Single Disk Type Coupling (High Strength Aluminum Alloy Body)

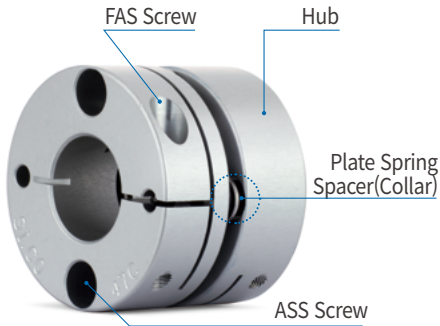

## Structure and Material

Structure	Material	Surface Treatment
Hub	High Strength Aluminum Alloy	Anodizing
Plate Spring	Stainless Steel	-
Spacer(Collar)	Steel	Black Oxide
Assembly Screw	SCM435	Black Oxide
Fastening Screw	SCM435	Black Oxide

## Product Features & Application

Backlash free (Precision)		☆
High Torque (Durability)		○
Torsional Stiffness		☆
Vibration Absorption		-
Misalignment Absorption		△
Applicable Motors	Servo	○
	Stepping	○
	Encoder	○
	General	-

**Application :** Semi-conductor manufacturing machine, SMT, Cartesian Robot, UVW Stage, Machine tools, Index Table

## Parts with Alternative Material Options

- Sung-il Machinery provides alternative material options for Coupling parts for customers who are worried about corrosion on Black oxide finish. Please see the below table for more details.

Mark	Material	Surface Treatment
No mark	Steel	Black Oxide
NI/ASS	Steel	Electroless Nickel Plating
SUS/ASS	Stainless Steel	-



- Caution: Slip torque would become lower if the body material or surface treatment of screws are changed from the standard version.

## Clamping Methods

Set-screw (No mark)	General	△
	With Keyway	△
Side-clamp (C)	General	○
	Hub Split	△
	With Keyway	○
Taper-ring (T)		X

※ You may check the sizes that Side-clamp Hub Split type is applicable from the "Dimensions / Performance" tables in the following pages.

## How to Order

**SDS - 80 CW - 20 W K6 x 35 W K10**

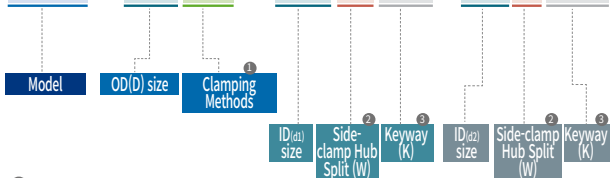

1 Clamping Methods	No mark	Set-screw	
	C	General Side-clamp	
	CW	Side-clamp Hub Split	
2 Side-clamp Hub Split	No mark	Not Split	Keyway
	W	Split (Only applicable on Side-clamp Type)	No mark
			No Keyway
			K(b size)

※ To verify the precise appearance of the product, please refer to the standard product drawing files provided on the top of our website's specification table or in the technical data section.

# SD SERIES (SDS)

## Single Disk Type Coupling (High Strength Aluminum Alloy Body)

### Set-Screw

Cylinder-shaped

Flange-shaped

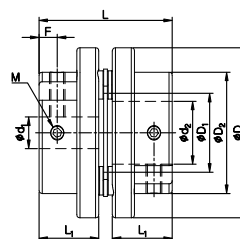
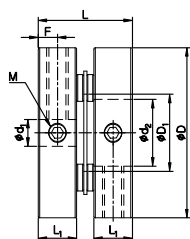

### Dimensions / Performance

Model	Shape	Size (±0.3mm)						Screw		Permissible Torque (N·m)	Max. rpm (min <sup>-1</sup> )	Moment of Inertia (kg·m <sup>2</sup> )	Static Torsional Stiffness (N·m/rad)	Mass (g)	Permissible Misalignment		
		D	D <sub>1</sub>	D <sub>2</sub>	L	L <sub>1</sub>	F	Size	Fastening Torque (N·m)						Angular (°)	Parallel (mm)	End-play (mm)
SDS-16	Cylinder	16	6.7	-	12	5.1	2.5	M2.5	0.5	0.6	16,000	1.8×10 <sup>-7</sup>	270	5	0.5	0.02	±0.1
SDS-19		19	8.5	-	14.1	6.1	3	M3	0.7	0.9	16,000	3.0×10 <sup>-7</sup>	600	6	1	0.02	±0.1
SDS-22		22.2	10	-	14.8	6.2	3	M3	0.7	1.2	12,000	6.9×10 <sup>-7</sup>	600	10	1	0.02	±0.1
SDS-26		26.6	12.2	-	17.6	7.4	3.6	M4	1.7	2.2	12,000	2.0×10 <sup>-6</sup>	900	20	1	0.02	±0.15
SDS-31		31.8	14.4	-	17.6	7.2	3.6	M4	1.7	4	10,000	4.4×10 <sup>-6</sup>	1,700	30	1	0.02	±0.2
SDS-42	Flange / Cylinder	42.5	18	29.3 / -	30.8 / 31.4	13.4 / 13.7	4.6 / 6.5	M4	1.7	8	8,000	1.7×10 <sup>-5</sup>	2,800	65	1	0.02	±0.25
SDS-42(3)		42.5	18	29.3 / -	31.1 / 31.7	13.4 / 13.7	4.6 / 6.5	M4	1.7	10	8,000	1.7×10 <sup>-5</sup>	2,800	65	1	0.02	±0.25
SDS-47		47	20.4	33 / -	31.4 / 35.7	13.9 / 16	4.5 / 7.1	M5	4	14	8,000	2.7×10 <sup>-5</sup>	6,000	91	1	0.02	±0.25
SDS-54		54	25	38.5 / -	42.3	19	5.8 / 6.4	M5	4	25	7,500	4.9×10 <sup>-5</sup>	11,000	130	1	0.02	±0.25
SDS-64		64	25.8	48 / -	58.2	26	8 / 11	M8	15	40	7,000	1.8×10 <sup>-4</sup>	20,000	292	1	0.02	±0.25

- The Moment of Inertia and Mass values are based on products with max. Inner diameter.
- Permissible Torque is the value regarding to a coupling's self-durability and is not related to slip-torque between the coupling bore and the shaft. (In general, the clamping force on set-screw type is weaker, therefore it is recommended that an additional keyway is processed for the enhanced clamping force.)
- If the same model has two different shapes (cylinder, flange), please indicate the cylinder type with the identification code 'D' after the inner diameter.

### Standard Inner Diameter (ID)

Model	Standard Inner Diameter (d <sub>1</sub> , d <sub>2</sub> ) (mm)																													
	3	4	4.5	5	6	6.35	7	8	9	9.525	10	11	12	12.7	14	15	15.875	16	17	18	19	20	21	22	24	25	26	28	30	
SDS-16	●	●	●	●																										
SDS-19	●	●	●	●	●																									
SDS-22	●	●	●	●	●	●	●	●	●	●★																				
SDS-26		●	●	●	●	●	●	●	●	●	●																			
SDS-31				●	●	●	●	●	●	●	●	●	●	●	●★	●★														
SDS-42					●	●	●	●	●	●	●	●	●	●	●	●														
SDS-47								●	●	●	●	●	●	●	●	●	●	●	●	●	●	●								
SDS-54											●	●	●	●	●	●	●	●	●	●	●	●	●							
SDS-64														●	●	●	●	●	●	●	●	●	●	●	●	●	●★	●★	●★	●★

- The recommended shaft tolerance is h7.
- Custom process (e.g. non-standard Inner diameter, special tolerance etc.) is also available upon a special request in prior to order placement.
- Keyway is available. (Optional)
- Due to interference of the middle parts, make sure the shaft is only inserted into L<sub>1</sub> depth for IDs with ★ mark. Consult us first if you're concerned about misalignment.

# SD SERIES (SDS)

Single Disk Type Coupling (High Strength Aluminum Alloy Body)

## Side-clamp

Cylinder-shaped

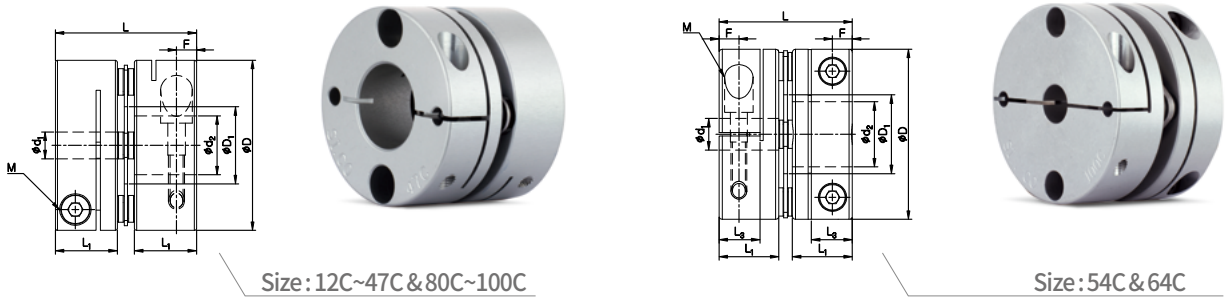

### Dimensions / Performance

Model	Size (±0.3mm)						Screw Size	Fastening Torque (N·m)	Permissible Torque (N·m)	Max. rpm (min <sup>-1</sup> )	Moment of Inertia (kg·m <sup>2</sup> )	Static Torsional Stiffness (N·m/rad)	Mass (g)	Permissible Misalignment			Side-clamp Hub Split (W)
	D	D <sub>1</sub>	L	L <sub>1</sub>	L <sub>3</sub>	F								Angular (°)	Parallel (mm)	End-play (mm)	
SDS-12C	12	5.5	12.3	5.9	-	1.9	M1.6	0.25	0.2	14,000	6.9×10 <sup>-8</sup>	170	3	0.5	0.01	±0.04	X
SDS-16C	16	6.7	17.4	7.8	-	2.5	M2	0.5	0.6	14,000	2.6×10 <sup>-7</sup>	270	7	1	0.02	±0.1	X
SDS-19C	19	8.5	19.3	8.7	-	2.9	M2.6	1	0.9	14,000	4.0×10 <sup>-7</sup>	500	8	1	0.02	±0.1	X
SDS-22C	22.2	10	19.7	8.7	-	2.8	M2.6	1	1.2	10,000	1.0×10 <sup>-6</sup>	600	15	1	0.02	±0.1	X
SDS-26C	26.6	12.2	24.1	10.6	-	3.4	M3	1.7	2.2	10,000	2.4×10 <sup>-6</sup>	900	25	1	0.02	±0.15	X
SDS-31C	31.8	14.4	26.4	11.6	-	3.7	M3	1.7	4	9,000	5.8×10 <sup>-6</sup>	1,700	40	1	0.02	±0.2	X
SDCS-35C	35	16.2	28	12.7	-	4.4	M4	3.5	5	8,500	1.0×10 <sup>-5</sup>	2,000	57	1	0.02	±0.2	X
SDS-39C	39	17	31.3	13.7	-	4.3	M4	3.5	6	8,000	1.6×10 <sup>-5</sup>	2,300	70	1	0.02	±0.25	X
SDS-39C(3)	39	17	31.6	13.7	-	4.3	M4	3.5	9	8,000	1.6×10 <sup>-5</sup>	2,300	70	1	0.02	±0.25	X
SDCS-42C	42.5	18	31.4	13.7	-	4.3	M4	3.5	8	8,000	3.4×10 <sup>-5</sup>	2,800	95	1	0.02	±0.25	X
SDCS-42C(3)	42.5	18	31.7	13.7	-	4.3	M4	3.5	10	8,000	3.4×10 <sup>-5</sup>	2,800	95	1	0.02	±0.25	X
SDCS-47C	47	20.5	35.6	16	-	5.2	M4	3.5	14	7,500	5.4×10 <sup>-5</sup>	6,000	140	1	0.02	±0.25	X
SDCS-54C	54	25	42.3	19	13	6.3	M5	8	25	7,500	9.8×10 <sup>-5</sup>	11,000	200	1	0.02	±0.25	○
SDCS-64C	64	25.8	58.2	26	15.2	7.5	M6	13	40	7,000	2.2×10 <sup>-4</sup>	20,000	355	1	0.02	±0.25	○
SDS-80C	80	35.8	66.1	29.7	19	9.4	M8	30	85	7,000	6.4×10 <sup>-4</sup>	40,000	690	1	0.02	±0.4	○
SDS-90C	94.5	41.6	68.9	30.4	19	9.3	M8	30	180	6,000	1.3×10 <sup>-3</sup>	60,000	960	1	0.02	±0.5	○
SDS-100C	104.5	47.7	71.7	30.7	19	9.3	M8	30	250	6,000	2.2×10 <sup>-3</sup>	70,000	1,300	1	0.02	±0.6	○

- The Moment of Inertia and Mass values are based on products with max. Inner diameter.
- Permissible Torque is the value regarding to a coupling's self-durability and is not related to slip-torque between the coupling bore and the shaft.
- Specially-designed split hubs are used for the size of 80C, 90C and 100C. (with 2 screws)

### Standard Inner Diameter (ID) 12C~47C

Model	Standard Inner Diameter (d <sub>1</sub> , d <sub>2</sub> ) (mm)																					
	3	4	4.5	5	6	6.35	7	8	9	9.525	10	11	12	12.7	14	15	15.875	16	17	18	19	20
SDS-12C	●	●		●★																		
SDS-16C	●	●	●	●																		
SDS-19C	●	●	●	●	●																	
SDS-22C	●	●	●	●	●	●	●	●	●	●★												
SDS-26C		●	●	●	●	●	●	●	●	●	●											
SDS-31C				●	●	●	●	●	●	●	●	●	●	●	●★	●★						
SDCS-35C				●	●	●	●	●	●	●	●	●	●	●	●	●	●	●★				
SDS-39C				●	●	●	●	●	●	●	●	●	●	●	●	●	●	●	●			
SDCS-42C					●	●	●	●	●	●	●	●	●	●	●	●	●	●	●	●★	●★	
SDCS-47C								●	●	●	●	●	●	●	●	●	●	●	●	●	●	●★

- The recommended shaft tolerance is h7.
- Custom process (e.g. non-standard Inner diameter, special tolerance etc.) is also available upon a special request in prior to order placement. (※ Exception Item: SDS-12C)
- Keyway is available. (Optional)
- Due to interference of the middle parts, make sure the shaft is only inserted into L<sub>1</sub> depth for IDs with ★ mark. Consult us first if you're concerned about misalignment.

# SD SERIES (SDS)

## Single Disk Type Coupling (High Strength Aluminum Alloy Body)

### Standard Inner Diameter (ID) 54C~100C

Model	Standard Inner Diameter (d <sub>1</sub> , d <sub>2</sub> ) (mm)																								
	10	11	12	12.7	14	15	15.875	16	17	18	19	20	22	24	25	26	28	30	32	35	40	45	50		
SDCS-54C	●	●	●	●	●	●	●	●	●	●	●	●	●	●	●★										
SDCS-64C			●	●	●	●	●	●	●	●	●	●	●	●	●★	●★	●★	●★	●★						
SDS-80C						●	●	●	●	●	●	●	●	●	●	●	●	●	●	●★					
SDS-90C												●	●	●	●	●	●	●	●	●	●	●	●★		
SDS-100C												●	●	●	●	●	●	●	●	●	●	●	●	●★	

- The recommended shaft tolerance is h7.
- Custom process (e.g. non-standard Inner diameter, special tolerance etc.) is also available upon a special request in prior to order placement.
- Keyway is available. (Optional)
- Side-clamp Hub Split is available (Optional)
- Due to interference of the middle parts, make sure the shaft is only inserted into L<sub>1</sub> depth for IDs with ★ mark. Consult us first if you're concerned about misalignment.

### Slip Torque

- The below table shows the actual permissible torque values when the slip torque value is lower than the coupling's permissible torque value.
- If the slip torque value is lower than the coupling's permissible torque value, please check and compare between the slip torque in the below table and the operating torque value of the connected motor. It is safer to size up the coupling or use a key/keyway when the slip torque value is lower than the motor's operating torque.
- The below slip torque values may be subject to change according to different testing conditions. (e.g. shaft tolerance, surface roughness, surface treatment or acceleration/deceleration of driving shafts). On the other hand, the values could be affected when a different kind of fastening screw is used (body material or surface treatment). Therefore, we recommend you test under the same conditions before mounting.

Model	Permissible Torque (N·m)	Slip Torque (N.m) by Inner Diameter (d <sub>1</sub> , d <sub>2</sub> )																								
		3	4	4.5	5	6	6.35	7	8	9	9.525	10	11	12	12.7	14	15	15.875	16							
SDS-16C	0.6	0.6																								
SDS-19C	0.9																									
SDS-22C	1.2	1.1																								
SDS-26C	2.2		2	2																						
SDS-31C	4				3																					
SDCS-35C	5				5																					
SDS-39C	6																									
SDS-39C(3)	9				5.5	6	6.5	7	9																	
SDCS-42C	8																									
SDCS-42C(3)	10					4.5	6	8	10																	
SDCS-47C	14									10	11	12	14													

Model	Permissible Torque (N·m)	Slip Torque (N.m) by Inner Diameter (d <sub>1</sub> , d <sub>2</sub> )																								
		10	11	12	12.7	14	15	16	18	19	20	22	24	25	28	30	32	35	40	45	50					
SDCS-54C	25																									
SDCS-64C	40			40																						
SDS-80C	85																									
SDS-90C	180										100	110	130	150												
SDS-100C	250										136	140	144	152	180	185	192	216	230	240	250					

### Side-clamp Hub Split(W) Option is available

- From certain outer diameter(OD) sizes, we can provide Side-clamp Hub Split products.
- Please refer to "HOW TO ORDER" page for more details.

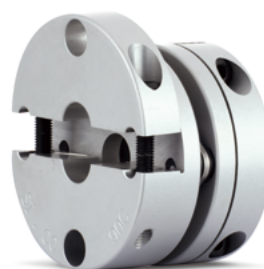

# SD SERIES (SDS)

## Single Disk Type Coupling (High Strength Aluminum Alloy Body)

### Side-clamp

Flange-shaped (Low-inertia)

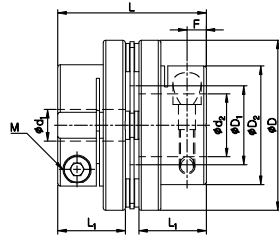

### Dimensions / Performance

Model	Size (±0.3mm)						Screw Size	Fastening Torque (N·m)	Permissible Torque (N·m)	Max. rpm (min <sup>-1</sup> )	Moment of Inertia (kg·m <sup>2</sup> )	Static Torsional Stiffness (N·m/rad)	Mass (g)	Permissible Misalignment		
	D	D <sub>1</sub>	D <sub>2</sub>	L	L <sub>1</sub>	F								Angular (°)	Parallel (mm)	End-play (mm)
SDS-35C	35	16.2	21.5	28	12.7	3.9	M3	1.7	5	8,500	4.6×10 <sup>-6</sup>	2,000	35	1	0.02	±0.2
SDS-42C	42.5	18	29.3	30.8	13.4	3.8	M3	1.7	8	8,000	1.7×10 <sup>-5</sup>	2,800	65	1	0.02	±0.25
SDS-42C(3)	42.5	18	29.3	31.1	13.4	3.8	M3	1.7	10	8,000	1.7×10 <sup>-5</sup>	2,800	65	1	0.02	±0.25
SDS-47C	47	20.5	33/*38	37	16.7	5	M4	3.5	14	8,000	3.2×10 <sup>-5</sup>	6,000	108	1	0.02	±0.25
SDS-54C	54	25	38.5	47.1	21.4	6.1	M5	8	25	8,000	5.5×10 <sup>-5</sup>	11,000	145	1	0.02	±0.25
SDS-64C	64	25.8	48	58.2	26	7.5	M6	13	40	7,000	1.8×10 <sup>-4</sup>	20,000	292	1	0.02	±0.25

- The Moment of Inertia and Mass values are based on products with max. Inner diameter.
- Permissible Torque is the value regarding to a coupling's self-durability and is not related to slip-torque between the coupling bore and the shaft.
- For OD 47C products, please refer to D<sub>2</sub> values with \* mark when inner diameters are bigger than 18mm.

### Standard Inner Diameter (ID)

Model	Standard Inner Diameter (d <sub>1</sub> , d <sub>2</sub> ) (mm)																						
	5	6	6.35	7	8	9	9.525	10	11	12	12.7	14	15	15.875	16	17	18	19	20	22	24	25	
SDS-35C	●	●	●	●	●	●	●	●															
SDS-42C		●	●	●	●	●	●	●	●	●	●	●	●										
SDS-47C				●	●	●	●	●	●	●	●	●	●	●	●	●	●	●	●				
SDS-54C								●	●	●	●	●	●	●	●	●	●	●	●	●			
SDS-64C										●	●	●	●	●	●	●	●	●	●	●	●	●	★

- The recommended shaft tolerance is h7.
- Custom process (e.g. non-standard Inner diameter, special tolerance etc.) is also available upon a special request in prior to order placement.
- Keyway is available. (Optional)
- Due to interference of the middle parts, make sure the shaft is only inserted into L<sub>1</sub> depth for IDs with ★ mark. Consult us first if you're concerned about misalignment.

### Slip Torque

- The below table shows the actual permissible torque values when the slip torque value is lower than the coupling's permissible torque value.
- If the slip torque value is lower than the coupling's permissible torque value, please check and compare between the slip torque in the below table and the operating torque value of the connected motor. It is safer to size up the coupling or use a key/keyway when the slip torque value is lower than the motor's operating torque.
- The below slip torque values may be subject to change according to different testing conditions. (e.g. shaft tolerance, surface roughness, surface treatment or acceleration/deceleration of driving shafts). On the other hand, the values could be affected when a different kind of fastening screw is used (body material or surface treatment). Therefore, we recommend you test under the same conditions before mounting.

Model	Permissible Torque (N·m)	Slip Torque (N.m) by Inner Diameter (d <sub>1</sub> , d <sub>2</sub> )																				
		5	6	6.35	7	8	9	9.525	10	11	12	12.7	14	15	15.875	16	17	18	19	20	21	
SDS-35C	5	3.2	3.5	3.8																		
SDS-42C	8		3	3	3.5	4	6	7	9	9.5	10											
SDS-42C(3)	10																					
SDS-47C	14					10	11	12	14													
SDS-54C	25																					
SDS-64C	40											36	37									

# SD SERIES (SDW)

Double Disk Type Coupling (High Strength Aluminum Alloy Body)

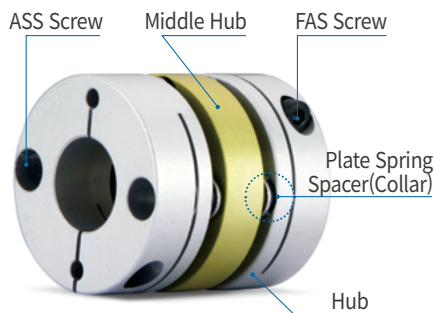

## Structure and Material

Structure	Material	Surface Treatment
Hub	High Strength Aluminum Alloy	Anodizing
Middle Hub	High Strength Aluminum Alloy	Anodizing
Plate Spring	Stainless Steel	-
Spacer(Collar)	Steel	Black Oxide
Assembly Screw	SCM435	Black Oxide
Fastening Screw	SCM435	Black Oxide

## Product Features & Application

Backlash free (Precision)		☆
High Torque (Durability)		○
Torsional Stiffness		☆
Vibration Absorption		-
Misalignment Absorption		○
Applicable Motors	Servo	○
	Stepping	○
	Encoder	○
	General	-

**Application :** Semi-conductor manufacturing machine, SMT, Cartesian Robot, UVW Stage, Machine tools, Index Table

## Parts with Alternative Material Options

Sung-il Machinery provides alternative material options for Coupling parts for customers who are worried about corrosion on Black oxide finish. Please see the below table for more details.

Mark	Material	Surface Treatment
No mark	Steel	Black Oxide
NI/ASS	Steel	Electroless Nickel Plating
SUS/ASS	Stainless Steel	-

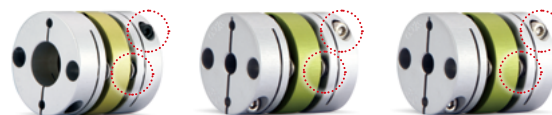

No mark                      NI/ASS                      SUS/ASS

Caution: Slip torque would become lower if the body material or surface treatment of screws are changed from the standard version.

## Clamping Methods

Set-screw (No mark)	General	△
	With Keyway	△
Side-clamp (C)	General	○
	Hub Split	△
	With Keyway	○
Taper-ring (T)		X

※ You may check the sizes that Side-clamp Hub Split type is applicable from the “Dimensions / Performance” tables in the following pages.

## How to Order

**SDW - 80 CW - 20 W K6 x 35 W K10**

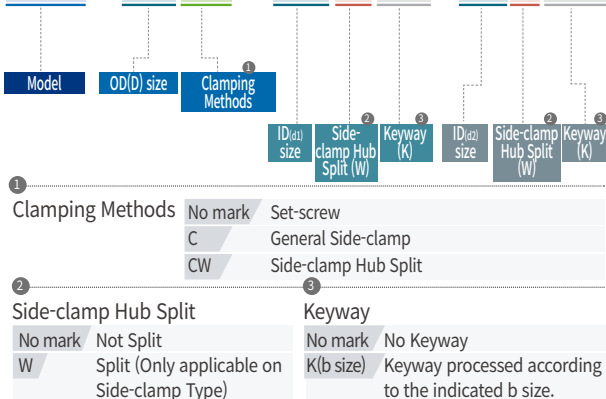

※ To verify the precise appearance of the product, please refer to the standard product drawing files provided on the top of our website's specification table or in the technical data section.

# SD SERIES (SDW)

## Double Disk Type Coupling (High Strength Aluminum Alloy Body)

### Set-Screw

#### Cylinder-shaped

##### General Type

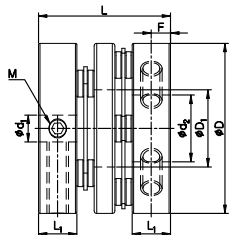

#### Flange-shaped

##### General Type

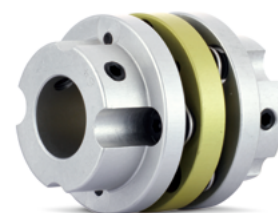
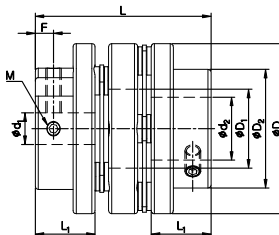

##### Lengthy Middle Body Type

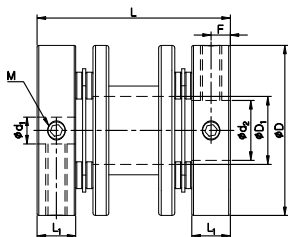

##### Lengthy Middle Body Type

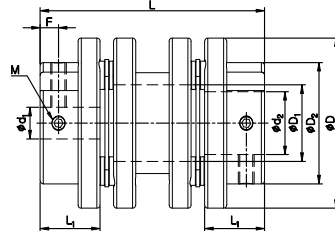

### Dimensions / Performance General Type

Model	Shape	Size (±0.3mm)						Screw		Permissible Torque (N·m)	Max. rpm (min <sup>-1</sup> )	Moment of Inertia (kg·m <sup>2</sup> )	Static Torsional Stiffness (N·m/rad)	Mass (g)	Permissible Misalignment		
		D	D <sub>1</sub>	D <sub>2</sub>	L	L <sub>1</sub>	F	Size	Fastening Torque (N·m)						Angular (°)	Parallel (mm)	End-play (mm)
SDWA-16	Cylinder	16	6.3	-	15.8	5.1	2.5	M2.5	0.5	0.6	16,000	2.2×10 <sup>-7</sup>	200	6	1	0.05	±0.2
SDWB-16		16	6.3	-	17.8	5.1	2.5	M2.5	0.5	0.6	16,000	2.6×10 <sup>-7</sup>	200	7	1	0.05	±0.2
SDWA-19		19	8.4	-	18.1	6.1	3	M3	0.7	0.9	16,000	5.3×10 <sup>-7</sup>	300	10	1	0.05	±0.2
SDWB-19		19	8.4	-	21.1	6.1	3	M3	0.7	0.9	16,000	5.8×10 <sup>-7</sup>	300	11	1	0.05	±0.2
SDWA-22		22.2	9	-	20.1	6.3	3	M3	0.7	1.2	12,000	1.0×10 <sup>-6</sup>	400	16	1.5	0.12	±0.2
SDWB-22		22.2	9	-	22.3	6.3	3	M3	0.7	1.2	12,000	1.1×10 <sup>-6</sup>	400	17	1.5	0.12	±0.2
SDWA-26		26.6	12.2	-	26	7.4	3.6	M4	1.7	2.2	12,000	2.3×10 <sup>-6</sup>	600	28	1.5	0.15	±0.3
SDWA-31		31.8	14.4	-	24.7	7.2	3.6	M4	1.7	4	10,000	4.3×10 <sup>-6</sup>	1,300	30	1.5	0.15	±0.4
SDWB-31		31.8	14.4	-	29.7	7.2	3.6	M4	1.7	4	10,000	5.5×10 <sup>-6</sup>	1,300	38	1.5	0.15	±0.4
SDWA-42		42.5	18	29.3 / -	39.7 / 40.3	13.4 / 13.7	4.6 / 6.5	M4	1.7	8	8,000	2.1×10 <sup>-5</sup>	2,000	84	1.5	0.18	±0.5
SDWA-42(3)	42.5	18	29.3 / -	40.3 / 40.9	13.4 / 13.7	4.6 / 6.5	M4	1.7	10	8,000	2.1×10 <sup>-5</sup>	2,000	84	1.5	0.18	±0.5	
SDWB-42	42.5	18	29.3 / -	44.2 / 44.8	13.4 / 13.7	4.6 / 6.5	M4	1.7	8	8,000	2.4×10 <sup>-5</sup>	2,000	94	1.5	0.18	±0.5	
SDWB-42(3)	42.5	18	29.3 / -	44.8 / 45.4	13.4 / 13.7	4.6 / 6.5	M4	1.7	10	8,000	2.4×10 <sup>-5</sup>	2,000	94	1.5	0.18	±0.5	
SDWA-47	Flange / Cylinder	47	20.4	33 / -	39.9 / 44.2	13.9 / 16	4.5 / 7.1	M5	4	14	8,000	3.4×10 <sup>-5</sup>	4,000	115	1.5	0.2	±0.5
SDWB-47		47	20.4	33 / -	45.7 / 50	13.9 / 16	4.5 / 7.1	M5	4	14	8,000	3.6×10 <sup>-5</sup>	4,000	120	1.5	0.2	±0.5
SDWA-54	Flange / Cylinder	54	25	38.5 / -	55.8	19	5.8 / 6.4	M5	4	25	7,500	6.7×10 <sup>-5</sup>	7,000	177	1.5	0.2	±0.5
SDWA-64		64	25.8	48 / -	74.4	26	8 / 11	M8	15	40	7,000	2.2×10 <sup>-4</sup>	11,000	373	1.5	0.3	±0.5

# SD SERIES (SDW)

## Double Disk Type Coupling (High Strength Aluminum Alloy Body)

### Dimensions / Performance Lengthy Middle Body Type

Model	Shape	Size (±0.3mm)						Screw Size	Fastening Torque (N·m)	Permissible Torque (N·m)	Max. rpm (min <sup>-1</sup> )	Moment of Inertia (kg·m <sup>2</sup> )	Static Torsional Stiffness (N·m/rad)	Mass (g)	Permissible Misalignment		
		D	D <sub>1</sub>	D <sub>2</sub>	L	L <sub>1</sub>	F								Angular (°)	Parallel (mm)	End-play (mm)
SDA-22	Cylinder	22.2	8.3	-	28.3	6.3	3	M3	0.7	1.2	12,000	1.3×10 <sup>-6</sup>	400	18	1.5	0.12	±0.2
SDA-26		26.6	10.5	-	31.7	7.4	3.6	M4	1.7	2.2	12,000	3.2×10 <sup>-6</sup>	600	32	1.5	0.15	±0.3
SDA-31		31.8	12.7	-	36.1	7.2	3.6	M4	1.7	4	10,000	5.5×10 <sup>-6</sup>	1,300	38	1.5	0.15	±0.4
SDAA-42	Flange / Cylinder	42.5	18	29.3 / -	50 / 50.6	13.4 / 13.7	4.6 / 6.5	M4	1.7	8	8,000	2.7×10 <sup>-5</sup>	2,000	105	1.5	0.18	±0.5
SDAA-42(3)		42.5	18	29.3 / -	50.6 / 51.2	13.4 / 13.7	4.6 / 6.5	M4	1.7	10	8,000	2.7×10 <sup>-5</sup>	2,000	105	1.5	0.18	±0.5
SDAB-42		42.5	18	29.3 / -	57.9 / 58.5	13.4 / 13.7	4.6 / 6.5	M4	1.7	8	8,000	2.8×10 <sup>-5</sup>	2,000	110	1.5	0.18	±0.5
SDAB-42(3)		42.5	18	29.3 / -	58.5 / 59.1	13.4 / 13.7	4.6 / 6.5	M4	1.7	10	8,000	2.8×10 <sup>-5</sup>	2,000	110	1.5	0.18	±0.5
SDAC-42		42.5	18	29.3 / -	67.3 / 67.9	13.4 / 13.7	4.6 / 6.5	M4	1.7	8	8,000	2.9×10 <sup>-5</sup>	2,000	115	1.5	0.18	±0.5
SDAC-42(3)		42.5	18	29.3 / -	67.9 / 68.5	13.4 / 13.7	4.6 / 6.5	M4	1.7	10	8,000	2.9×10 <sup>-5</sup>	2,000	115	1.5	0.18	±0.5
SDAA-47		47	20	33 / -	58.1 / 62.4	13.9 / 16	4.5 / 7.1	M5	4	14	8,000	4.2×10 <sup>-5</sup>	4,000	140	1.5	0.2	±0.5
SDAB-47		47	20	33 / -	85 / 89.3	13.9 / 16	4.5 / 7.1	M5	4	14	8,000	4.7×10 <sup>-5</sup>	4,000	160	1.5	0.2	±0.5
SDAA-54		54	24.3	38.5 / -	71.2	19	5.8 / 6.4	M5	4	25	7,500	9.0×10 <sup>-5</sup>	7,000	230	1.5	0.2	±0.5
SDAB-54		54	24.3	38.5 / -	85.1	19	5.8 / 6.4	M5	4	25	7,500	1.1×10 <sup>-4</sup>	7,000	250	1.5	0.2	±0.5
SDA-64		64	25.8	48 / -	89.9	26	8 / 11	M8	15	40	7,000	2.7×10 <sup>-4</sup>	11,000	450	1.5	0.3	±0.5

- The Moment of Inertia and Mass values are based on products with max. Inner diameter.
- **Non-standard lengthy middle body type can be customized.**
- Permissible Torque is the value regarding to a coupling's self-durability and is not related to slip-torque between the coupling bore and the shaft.  
(In general, the clamping force on set-screw type is weaker, therefore it is recommended that an additional keyway is processed for the enhanced clamping force.)
- If the same model has two different shapes (cylinder, flange), please indicate the cylinder type with the identification code 'D' after the inner diameter.

### Standard Inner Diameter (ID)

Model	Standard Inner Diameter (d <sub>1</sub> , d <sub>2</sub> ) (mm)																													
	3	4	4.5	5	6	6.35	7	8	9	9.525	10	11	12	12.7	14	15	15.875	16	17	18	19	20	21	22	24	25	26	28	30	
SD□□-16	●	●	●	●																										
SD□□-19	●	●	●	●	●																									
SD□□-22	●	●	●	●	●	●	●	●	●★	●★																				
SD□□-26		●	●	●	●	●	●	●	●	●	●																			
SD□□-31				●	●	●	●	●	●	●	●	●	●	●	●★	●★														
SD□□-42					●	●	●	●	●	●	●	●	●	●	●	●														
SD□□-47								●	●	●	●	●	●	●	●	●	●	●	●	●	●	●								
SD□□-54											●	●	●	●	●	●	●	●	●	●	●	●	●							
SD□□-64												●	●	●	●	●	●	●	●	●	●	●	●	●	●	●	●★	●★	●★	●★

- The recommended shaft tolerance is h7.
- Custom process (e.g. non-standard inner diameter, special tolerance etc.) is also available upon a special request in prior to order placement.
- Keyway is available. (Optional)
- Due to interference of the middle parts, make sure the shaft is only inserted into L<sub>1</sub> depth for IDs with ★ mark. Consult us first if you're concerned about misalignment.

# SD SERIES (SDW)

## Double Disk Type Coupling (High Strength Aluminum Alloy Body)

### Side-clamp

#### Cylinder-shaped

##### General Type

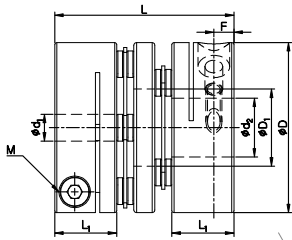

Size : 12C~47C & 80C~100C

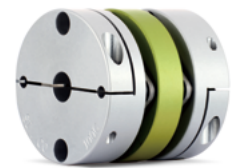
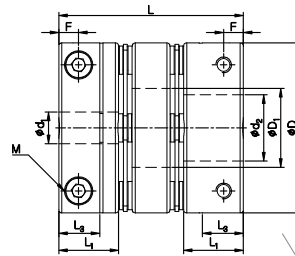

Size : 54C & 64C

##### Lengthy Middle Body Type

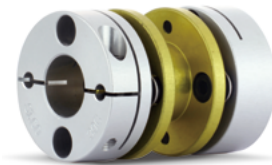
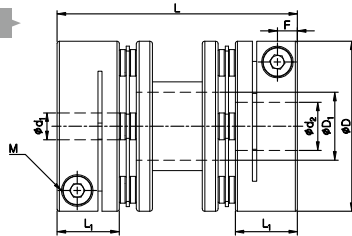

### Dimensions / Performance

#### General Type

Model	Size (±0.3mm)						Screw		Permissible Torque (N·m)	Max. rpm (min <sup>-1</sup> )	Moment of Inertia (kg·m <sup>2</sup> )	Static Torsional Stiffness (N·m/rad)	Mass (g)	Permissible Misalignment		End-play (mm)	Side-clamp Hub Split (W)
	D	D <sub>1</sub>	L	L <sub>1</sub>	L <sub>3</sub>	F	Size	Fastening Torque (N·m)						Angular (°)	Parallel (mm)		
SDWA-12C	12	5.5	15.7	5.9	-	1.9	M1.6	0.25	0.2	14,000	7.5×10 <sup>-8</sup>	85	4	1	0.03	±0.08	X
SDWA-16C	16	6.3	21.2	7.8	-	2.5	M2	0.5	0.6	14,000	3.3×10 <sup>-7</sup>	200	9	1	0.05	±0.2	X
SDWB-16C	16	6.3	23.2	7.8	-	2.5	M2	0.5	0.6	14,000	3.7×10 <sup>-7</sup>	200	10	1	0.05	±0.2	X
SDWA-19C	19	8.4	23.3	8.7	-	2.9	M2.6	1	0.9	14,000	7.4×10 <sup>-7</sup>	300	14	1	0.05	±0.2	X
SDWB-19C	19	8.4	26.3	8.7	-	2.9	M2.6	1	0.9	14,000	7.9×10 <sup>-7</sup>	300	15	1	0.05	±0.2	X
SDWA-22C	22.2	9	25	8.7	-	2.8	M2.6	1	1.2	10,000	1.3×10 <sup>-6</sup>	400	18	1.5	0.12	±0.2	X
SDWB-22C	22.2	9	27.2	8.7	-	2.8	M2.6	1	1.2	10,000	1.4×10 <sup>-6</sup>	400	19	1.5	0.12	±0.2	X
SDWA-26C	26.6	12.2	32.5	10.6	-	3.4	M3	1.7	2.2	10,000	3.4×10 <sup>-6</sup>	600	34	1.5	0.15	±0.3	X
SDWA-31C	31.8	14.4	33.5	11.6	-	3.7	M3	1.7	4	9,000	7.5×10 <sup>-6</sup>	1,300	52	1.5	0.15	±0.4	X
SDWB-31C	31.8	14.4	38.5	11.6	-	3.7	M3	1.7	4	9,000	8.8×10 <sup>-6</sup>	1,300	60	1.5	0.15	±0.4	X
SDWA-35C	35	16.2	34.6	12.7	-	4.4	M4	3.5	5	8,500	1.2×10 <sup>-5</sup>	1,500	67	1.5	0.16	±0.4	X
SDWC-35C	35	16.2	38.1	12.7	-	4.4	M4	3.5	5	8,500	1.4×10 <sup>-5</sup>	1,500	75	1.5	0.16	±0.4	X
SDWA-39C	39	17	39.5	13.7	-	4.3	M4	3.5	6	8,000	2.1×10 <sup>-5</sup>	1,800	95	1.5	0.18	±0.4	X
SDWA-39C(3)	39	17	40.1	13.7	-	4.3	M4	3.5	9	8,000	2.1×10 <sup>-5</sup>	1,800	95	1.5	0.18	±0.4	X
SDWC-39C	39	17	45	13.7	-	4.3	M4	3.5	6	8,000	2.4×10 <sup>-5</sup>	1,800	110	1.5	0.18	±0.4	X
SDWC-39C(3)	39	17	45.6	13.7	-	4.3	M4	3.5	9	8,000	2.4×10 <sup>-5</sup>	1,800	110	1.5	0.18	±0.4	X
SDWC-42C	42.5	18	46.2	13.7	-	4.3	M4	3.5	8	8,000	3.3×10 <sup>-5</sup>	2,000	120	1.5	0.18	±0.5	X
SDWC-42C(3)	42.5	18	46.8	13.7	-	4.3	M4	3.5	10	8,000	3.3×10 <sup>-5</sup>	2,000	120	1.5	0.18	±0.5	X
SDWC-47C	47	20.5	50	16	-	5.2	M4	3.5	14	7,500	5.5×10 <sup>-5</sup>	4,000	160	1.5	0.2	±0.5	X
SDWB-54C	54	25	52.6	19	13	6.3	M5	8	25	7,500	1.1×10 <sup>-4</sup>	7,000	250	1.5	0.2	±0.5	○
SDWC-54C	54	25	58.6	19	13	6.3	M5	8	25	7,500	1.2×10 <sup>-4</sup>	7,000	280	1.5	0.2	±0.5	○
SDWB-64C	64	25.8	74.4	26	15.2	7.5	M6	13	40	6,500	3.5×10 <sup>-4</sup>	11,000	455	1.5	0.3	±0.5	○
SDWC-64C	64	25.8	84.4	26	15.2	7.5	M6	13	40	6,500	4.8×10 <sup>-4</sup>	11,000	530	1.5	0.3	±0.5	○
SDW-80C	80	35.8	81.8	29.7	19	9.4	M8	30	85	6,000	8.1×10 <sup>-4</sup>	20,000	860	2	0.4	±0.6	○
SDWC-80C	80	35.8	98.3	29.7	19	9.4	M8	30	85	6,000	9.7×10 <sup>-4</sup>	20,000	1,020	2	0.5	±0.6	○
SDW-90C	94.5	41.6	98.9	30.4	19	9.3	M8	30	180	6,000	1.8×10 <sup>-3</sup>	35,000	1,360	2	0.4	±0.8	○
SDW-100C	104.5	47.7	103.8	30.7	19	9.3	M8	30	250	6,000	2.9×10 <sup>-3</sup>	50,000	1,700	2	0.4	±0.8	○

- The Moment of Inertia and Mass values are based on products with max. Inner diameter.
- Permissible Torque is the value regarding to a coupling's self-durability and is not related to slip-torque between the coupling bore and the shaft.
- Specially-designed split hubs are used for the size of 80C, 90C and 100C. (with 2 screws)

# SD SERIES (SDW)

## Double Disk Type Coupling (High Strength Aluminum Alloy Body)

### Dimensions / Performance Lengthy Middle Body Type

Model	Size (±0.3mm)					Screw		Permissible Torque (N·m)	Max. rpm (min <sup>-1</sup> )	Moment of Inertia (kg·m <sup>2</sup> )	Static Torsional Stiffness (N·m/rad)	Mass (g)	Permissible Misalignment			Side-clamp Hub Split (W)
	D	D <sub>1</sub>	L	L <sub>1</sub>	F	Size	Fastening Torque (N·m)						Angular (°)	Parallel (mm)	End-play (mm)	
SDA-22C	22.2	8.3	33.2	8.7	2.8	M2.6	1	1.2	10,000	1.5×10 <sup>-6</sup>	400	20	1.5	0.12	±0.2	X
SDA-26C	26.6	10.5	38.2	10.6	3.4	M3	1.7	2.2	10,000	3.9×10 <sup>-6</sup>	600	39	1.5	0.15	±0.3	X
SDA-31C	31.8	12.7	44.9	11.6	3.7	M3	1.7	4	9,000	8.8×10 <sup>-6</sup>	1,300	60	1.5	0.15	±0.4	X
SDA-39C	39	15.3	56.5	13.7	4.3	M4	3.5	6	8,000	3.0×10 <sup>-5</sup>	1,800	120	1.5	0.18	±0.4	X
SDA-39C(3)	39	15.3	57.1	13.7	4.3	M4	3.5	9	8,000	3.0×10 <sup>-5</sup>	1,800	120	1.5	0.18	±0.4	X

- The Moment of Inertia and Mass values are based on products with max. Inner diameter.
- Non-standard lengthy middle body type can be customized.**
- Permissible Torque is the value regarding to a coupling's self-durability and is not related to slip-torque between the coupling bore and the shaft.

### Standard Inner Diameter (ID) 12C ~ 47C

Model	Standard Inner Diameter (d <sub>1</sub> , d <sub>2</sub> ) (mm)																					
	3	4	4.5	5	6	6.35	7	8	9	9.525	10	11	12	12.7	14	15	15.875	16	17	18	19	20
SD□□-12C	●	●		●★																		
SD□□-16C	●	●	●	●																		
SD□□-19C	●	●	●	●	●																	
SD□□-22C	●	●	●	●	●	●	●	●	●★	●★												
SD□□-26C		●	●	●	●	●	●	●	●	●	●											
SD□□-31C				●	●	●	●	●	●	●	●	●	●	●★	●★							
SD□□-35C				●	●	●	●	●	●	●	●	●	●	●	●	●★	●★					
SD□□-39C				●	●	●	●	●	●	●	●	●	●	●	●	●	●	●				
SD□□-42C					●	●	●	●	●	●	●	●	●	●	●	●	●	●	●	●★	●★	
SD□□-47C								●	●	●	●	●	●	●	●	●	●	●	●	●	●	●★

- The recommended shaft tolerance is h7.
- Custom process (e.g. non-standard Inner diameter, special tolerance etc.) is also available upon a special request in prior to order placement.  
(※ Exception Item: SDWA-12C)
- Keyway is available. (Optional)
- Due to interference of the middle parts, make sure the shaft is only inserted into L<sub>1</sub> depth for IDs with ★ mark. Consult us first if you're concerned about misalignment.

### Standard Inner Diameter (ID) 54C ~ 100C

Model	Standard Inner Diameter (d <sub>1</sub> , d <sub>2</sub> ) (mm)																						
	10	11	12	12.7	14	15	15.875	16	17	18	19	20	22	24	25	26	28	30	32	35	40	45	50
SD□□-54C	●	●	●	●	●	●	●	●	●	●	●	●	●	●	●★								
SD□□-64C			●	●	●	●	●	●	●	●	●	●	●	●	●★	●★	●★	●★	●★				
SD□□-80C					●	●	●	●	●	●	●	●	●	●	●	●	●	●	●	●★			
SD□□-90C											●	●	●	●	●	●	●	●	●	●	●	●★	
SD□□-100C											●	●	●	●	●	●	●	●	●	●	●	●	●★

- The recommended shaft tolerance is h7.
- Custom process (e.g. non-standard Inner diameter, special tolerance etc.) is also available upon a special request in prior to order placement.
- Keyway is available. (Optional)
- Due to interference of the middle parts, make sure the shaft is only inserted into L<sub>1</sub> depth for IDs with ★ mark. Consult us first if you're concerned about misalignment.
- Side-clamp Hub Split is available (Optional)

# SD SERIES (SDW)

## Double Disk Type Coupling (High Strength Aluminum Alloy Body)

### Slip Torque

- The below table shows the actual permissible torque values when the slip torque value is lower than the coupling's permissible torque value.
- If the slip torque value is lower than the coupling's permissible torque value, please check and compare between the slip torque in the below table and the operating torque value of the connected motor. It is safer to size up the coupling or use a key/keyway when the slip torque value is lower than the motor's operating torque.
- The below slip torque values may be subject to change according to different testing conditions. (e.g. shaft tolerance, surface roughness, surface treatment or acceleration/deceleration of driving shafts). On the other hand, the values could be affected when a different kind of fastening screw is used (body material or surface treatment). Therefore, we recommend you test under the same conditions before mounting.

Model	Permissible Torque (N·m)	Slip Torque (N.m) by Inner Diameter (d <sub>1</sub> , d <sub>2</sub> )																	
		3	4	4.5	5	6	6.35	7	8	9	9.525	10	11	12	12.7	14	15	15.875	16
SD□□-16C	0.6	0.6																	
SD□□-19C	0.9																		
SD□□-22C	1.2	1.1																	
SD□□-26C	2.2		2	2															
SD□□-31C	4				3														
SD□□-35C	5				5														
SD□□-39C	6				5.5	6	6.5	7	9										
SD□□-39C(3)	9																		
SD□□-42C	8					4.5	6	8	10										
SD□□-42C(3)	10																		
SD□□-47C	14								10	11	12								

Model	Permissible Torque (N·m)	Slip Torque (N.m) by Inner Diameter (d <sub>1</sub> , d <sub>2</sub> )																			
		10	11	12	12.7	14	15	16	18	19	20	22	24	25	28	30	32	35	40	45	50
SD□□-54C	25																				
SD□□-64C	40																				
SD□□-80C	85																				
SD□□-90C	180									100	110	130	150								
SD□□-100C	250									136	140	144	152	180	185	192	216	230	240	250	

### Side-clamp Hub Split(W) Option is available

- From certain outer diameter(OD) sizes, we can provide Side-clamp Hub Split products.
- Please refer to "HOW TO ORDER" page for more details.



# SD SERIES (SDW)

## Double Disk Type Coupling (High Strength Aluminum Alloy Body)

### Side-clamp

#### Flange-shaped (Low-inertia)

##### General Type

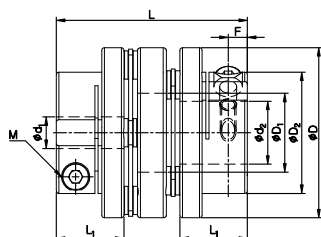

##### Lengthy Middle Body Type

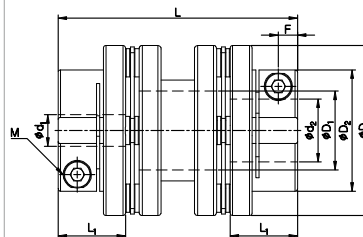

#### Dimensions / Performance General Type

Model	Size ( $\pm 0.3\text{mm}$ )						Screw		Permissible Torque (N·m)	Max. rpm ( $\text{min}^{-1}$ )	Moment of Inertia ( $\text{kg}\cdot\text{m}^2$ )	Static Torsional Stiffness (N·m/rad)	Mass (g)	Permissible Misalignment		
	D	D <sub>1</sub>	D <sub>2</sub>	L	L <sub>1</sub>	F	Size	Fastening Torque (N·m)						Angular (°)	Parallel (mm)	End-play (mm)
SDWB-35C	35	16.2	21.5	34.6	12.7	3.9	M3	1.7	5	8,500	$6.1 \times 10^{-6}$	1,500	44	1.5	0.16	$\pm 0.4$
SDWD-35C	35	16.2	21.5	38.1	12.7	3.9	M3	1.7	5	8,500	$8.2 \times 10^{-6}$	1,500	55	1.5	0.16	$\pm 0.4$
SDWA-42C	42.5	18	29.3	39.7	13.4	3.8	M3	1.7	8	8,000	$2.1 \times 10^{-5}$	2,000	84	1.5	0.18	$\pm 0.5$
SDWA-42C(3)	42.5	18	29.3	40.3	13.4	3.8	M3	1.7	10	8,000	$2.1 \times 10^{-5}$	2,000	84	1.5	0.18	$\pm 0.5$
SDWB-42C	42.5	18	29.3	44.2	13.4	3.8	M3	1.7	8	8,000	$2.4 \times 10^{-5}$	2,000	94	1.5	0.18	$\pm 0.5$
SDWB-42C(3)	42.5	18	29.3	44.8	13.4	3.8	M3	1.7	10	8,000	$2.4 \times 10^{-5}$	2,000	94	1.5	0.18	$\pm 0.5$
SDWA-47C	47	20.5	33/*38	45.6	16.7	5	M4	3.5	14	7,500	$3.6 \times 10^{-5}$	4,000	120	1.5	0.2	$\pm 0.5$
SDWB-47C	47	20.5	33/*38	51.4	16.7	5	M4	3.5	14	7,500	$3.9 \times 10^{-5}$	4,000	132	1.5	0.2	$\pm 0.5$
SDWA-54C	54	25	38.5	60.6	21.4	6.1	M5	8	25	7,500	$7.2 \times 10^{-5}$	7,000	192	1.5	0.2	$\pm 0.5$
SDWA-64C	64	25.8	48	74.4	26	7.5	M6	13	40	6,500	$2.2 \times 10^{-4}$	11,000	373	1.5	0.3	$\pm 0.5$

- The Moment of Inertia and Mass values are based on products with max. Inner diameter.
- Permissible Torque is the value regarding to a coupling's self-durability and is not related to slip-torque between the coupling bore and the shaft.
- Please refer to \* marked value for D2 of OD 47 products when ID is over 18mm.

#### Dimensions / Performance Lengthy Middle Body Type

Model	Size ( $\pm 0.3\text{mm}$ )						Screw		Permissible Torque (N·m)	Max. rpm ( $\text{min}^{-1}$ )	Moment of Inertia ( $\text{kg}\cdot\text{m}^2$ )	Static Torsional Stiffness (N·m/rad)	Mass (g)	Permissible Misalignment		
	D	D <sub>1</sub>	D <sub>2</sub>	L	L <sub>1</sub>	F	Size	Fastening Torque (N·m)						Angular (°)	Parallel (mm)	End-play (mm)
SDAA-42C	42.5	18	29.3	50	13.4	3.8	M3	1.7	8	8,000	$2.7 \times 10^{-5}$	2,000	105	1.5	0.18	$\pm 0.5$
SDAA-42C(3)	42.5	18	29.3	50.6	13.4	3.8	M3	1.7	10	8,000	$2.7 \times 10^{-5}$	2,000	105	1.5	0.18	$\pm 0.5$
SDAB-42C	42.5	18	29.3	57.9	13.4	3.8	M3	1.7	8	8,000	$2.8 \times 10^{-5}$	2,000	110	1.5	0.18	$\pm 0.5$
SDAB-42C(3)	42.5	18	29.3	58.5	13.4	3.8	M3	1.7	10	8,000	$2.8 \times 10^{-5}$	2,000	110	1.5	0.18	$\pm 0.5$
SDAC-42C	42.5	18	29.3	67.3	13.4	3.8	M3	1.7	8	8,000	$2.9 \times 10^{-5}$	2,000	115	1.5	0.18	$\pm 0.5$
SDAC-42C(3)	42.5	18	29.3	67.9	13.4	3.8	M3	1.7	10	8,000	$2.9 \times 10^{-5}$	2,000	115	1.5	0.18	$\pm 0.5$
SDAA-47C	47	20	33/*38	63.8	16.7	5	M4	3.5	14	7,500	$4.5 \times 10^{-5}$	4,000	152	1.5	0.2	$\pm 0.5$
SDAB-47C	47	20	33/*38	90.7	16.7	5	M4	3.5	14	7,500	$5.1 \times 10^{-5}$	4,000	172	1.5	0.2	$\pm 0.5$
SDAA-54C	54	24.3	38.5	76	21.4	6.1	M5	8	25	7,500	$9.0 \times 10^{-5}$	7,000	240	1.5	0.2	$\pm 0.5$
SDAB-54C	54	24.3	38.5	89.9	21.4	6.1	M5	8	25	7,500	$1.1 \times 10^{-4}$	7,000	266	1.5	0.2	$\pm 0.5$
SDA-64C	64	25.8	48	89.9	26	7.5	M6	13	40	6,500	$2.7 \times 10^{-4}$	11,000	450	1.5	0.3	$\pm 0.5$

- The Moment of Inertia and Mass values are based on products with max. Inner diameter.
- **Non-standard lengthy middle body type can be customized.**
- Permissible Torque is the value regarding to a coupling's self-durability and is not related to slip-torque between the coupling bore and the shaft.
- Please refer to \* marked value for D2 of OD 47 products when ID is over 18mm.

# SD SERIES (SDW)

## Double Disk Type Coupling (High Strength Aluminum Alloy Body)

### Standard Inner Diameter (ID)

Model	Standard Inner Diameter (d <sub>1</sub> , d <sub>2</sub> ) (mm)																					
	5	6	6.35	7	8	9	9.525	10	11	12	12.7	14	15	15.875	16	17	18	19	20	22	24	25
SD□□-35C	●	●	●	●	●	●	●	●														
SD□□-42C		●	●	●	●	●	●	●	●	●	●	●	●									
SD□□-47C					●	●	●	●	●	●	●	●	●	●	●	●	●	●				
SD□□-54C								●	●	●	●	●	●	●	●	●	●	●	●			
SD□□-64C										●	●	●	●	●	●	●	●	●	●	●	●	●★

- The recommended shaft tolerance is h7.
- Custom process (e.g. non-standard Inner diameter, special tolerance etc.) is also available upon a special request in prior to order placement.
- Keyway is available. (Optional)
- Due to interference of the middle parts, make sure the shaft is only inserted into L<sub>1</sub> depth for IDs with ★ mark. Consult us first if you're concerned about misalignment.

### Slip Torque

- The below table shows the actual permissible torque values when the slip torque value is lower than the coupling's permissible torque value.
- If the slip torque value is lower than the coupling's permissible torque value, please check and compare between the slip torque in the below table and the operating torque value of the connected motor. It is safer to size up the coupling or use a key/keyway when the slip torque value is lower than the motor's operational torque.
- The below slip torque values may be subject to change according to different testing conditions. (e.g. shaft tolerance, surface roughness, surface treatment or acceleration/deceleration of driving shafts). On the other hand, the values could be affected when a different kind of fastening screw is used (body material or surface treatment). Therefore, we recommend you test under the same conditions before mounting.

Model	Permissible Torque (N·m)	Slip Torque (N.m) by Inner Diameter (d <sub>1</sub> , d <sub>2</sub> )																			
		5	6	6.35	7	8	9	9.525	10	11	12	12.7	14	15	15.875	16	17	18	19	20	21
SD□□-35C	5	3.2	3.5	3.8																	
SD□□-42C	8		3	3	3.5	4	6	7	9	9.5	10										
SD□□-42C(3)	10																				
SD□□-47C	14					10	11	12	14												
SD□□-54C	25																				
SD□□-64C	40										36	37									

# SD SERIES (SDSS)

## Single Disk Type Coupling (Stainless Steel Body)

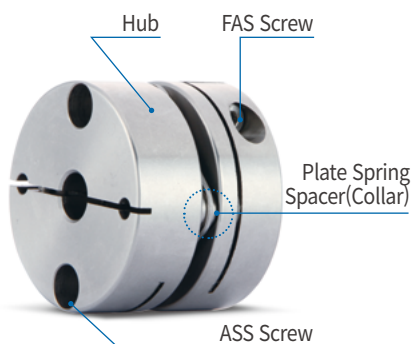

### Structure and Material

Structure	Material
Hub	Stainless Steel
Plate Spring	Stainless Steel
Spacer(Collar)	Stainless Steel
Assembly Screw	STS304
Fastening Screw	STS304

### Product Features & Application

Backlash free (Precision)		☆
High Torque (Durability)		○
Torsional Stiffness		☆
Vibration Absorption		-
Misalignment Absorption		△
Corrosion resistance		☆
Applicable Motors	Servo	○
	Stepping	○
	Encoder	○
	General	-

**Application :** Semi-conductor manufacturing machine, SMT, Cartesian Robot, UVW Stage, Machine tools, Index Table, and Corrosion resistant / High-precision / High-heated environment

### Why Stainless Steel Products are recommended?

1. Corrosion Resistance allows to be used in rusty environment.
2. The heat resistance is better than aluminum alloy material's so that it keeps the mechanical properties of materials staying normal in high temperature applications.

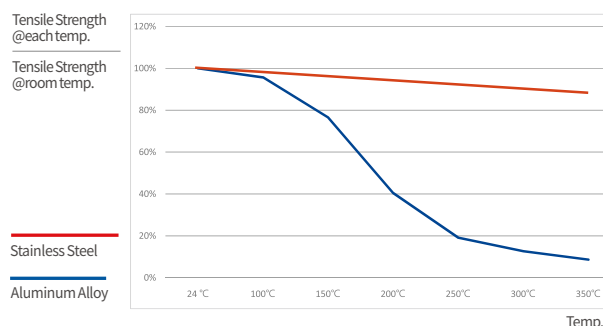

### Clamping Methods

Set-screw (No mark)	General	X
	With Keyway	X
Side-clamp (C)	General	○
	Hub Split	△
	With Keyway	○
Taper-ring (T)		X

※ You may check the sizes that Side-clamp Hub Split type is applicable from the "Dimensions / Performance" tables in the following pages.

### How to Order

**SDSS - 80 CW - 20 W K6 x 35 W K10**

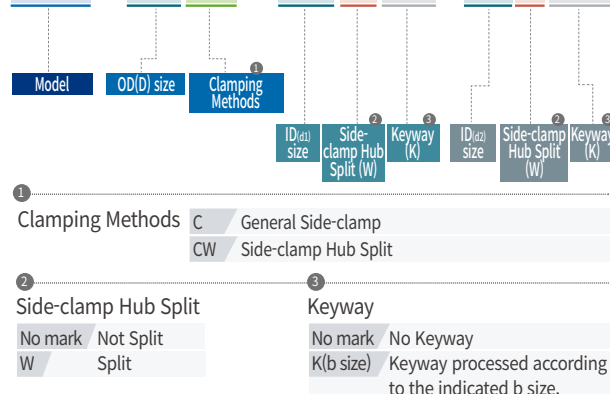

※ To verify the precise appearance of the product, please refer to the standard product drawing files provided on the top of our website's specification table or in the technical data section.

# SD SERIES (SDSS)

## Single Disk Type Coupling (Stainless Steel Body)

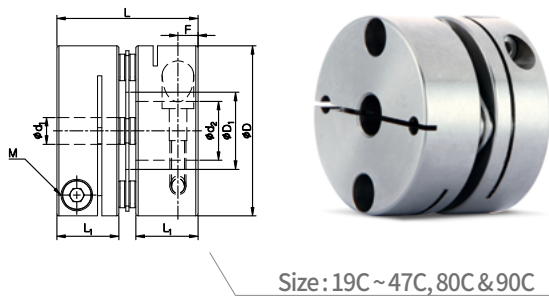

Size: 19C ~ 47C, 80C & 90C

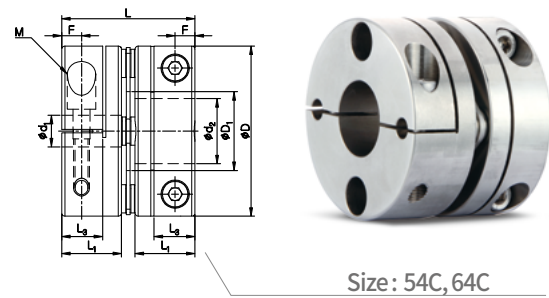

Size: 54C, 64C

### Dimensions / Performance

Model	Size (±0.3mm)						Screw Size	Fastening Torque (N·m)	Permissible Torque (N·m)	Max. rpm (min <sup>-1</sup> )	Moment of Inertia (kg·m <sup>2</sup> )	Static Torsional Stiffness (N·m/rad)	Mass (g)	Permissible Misalignment			Side-clamp Hub Split (W)
	D	D <sub>1</sub>	L	L <sub>1</sub>	L <sub>3</sub>	F								Angular (°)	Parallel (mm)	End-play (mm)	
SDSS-16C	16	6.7	17.4	7.8	-	2.5	M2	0.5	0.6	14,000	6.8 X 10 <sup>-7</sup>	270	19.4	1	0.02	±0.1	X
SDSS-19C	19	8.5	19.3	8.7	-	2.9	M2.6	1	0.9	14,000	1.0 x 10 <sup>-6</sup>	600	21	1	0.02	±0.1	X
SDSS-22C	22.2	10	19.7	8.7	-	2.8	M2.6	1	1.2	10,000	2.5 x 10 <sup>-6</sup>	600	42	1	0.02	±0.1	X
SDSS-26C	26.6	12.2	24.1	10.6	-	3.4	M3	1.5	2.2	10,000	6.0 x 10 <sup>-6</sup>	900	70	1	0.02	±0.15	X
SDSS-31C	31.8	14.4	26.4	11.6	-	3.7	M3	1.5	4	9,000	1.5 x 10 <sup>-5</sup>	1,700	112	1	0.02	±0.2	X
SDSS-35C	35	16.2	28	12.7	-	4.4	M4	2.5	5	8,500	2.5 x 10 <sup>-5</sup>	2,000	135	1	0.02	±0.2	X
SDSS-39C	39	17	31.3	13.7	-	4.3	M4	2.5	6	8,000	4.0 x 10 <sup>-5</sup>	2,300	196	1	0.02	±0.2	X
SDSS-39C(3)	39	17	31.6	13.7	-	4.3	M4	2.5	9	8,000	4.0 x 10 <sup>-5</sup>	2,300	196	1	0.02	±0.2	X
SDSS-42C	42.5	18	31.4	13.7	-	4.3	M4	2.5	8	8,000	8.5 x 10 <sup>-5</sup>	2,800	266	1	0.02	±0.25	X
SDSS-42C(3)	42.5	18	31.7	13.7	-	4.3	M4	2.5	10	8,000	8.5 x 10 <sup>-5</sup>	2,800	266	1	0.02	±0.25	X
SDSS-47C	47	20.5	35.6	16	-	5.2	M4	2.5	14	8,000	1.4 x 10 <sup>-4</sup>	6,000	392	1	0.02	±0.25	X
SDSS-54C	54	25	42.3	19	13	6.3	M5	4	25	8,000	2.5 x 10 <sup>-4</sup>	11,000	560	1	0.02	±0.25	○
SDSS-64C	64	25.8	58.2	26	15.2	7.5	M6	8	40	7,000	6.5 x 10 <sup>-4</sup>	20,000	950	1	0.02	±0.25	○
SDSS-80C	80	35.8	66.1	29.7	19	9.4	M8	20	85	7,000	1.6 x 10 <sup>-3</sup>	40,000	1,720	1	0.02	±0.4	○
SDSS-90C	94.5	41.6	68.9	30.4	19	9.3	M8	20	180	6,000	3.2 x 10 <sup>-3</sup>	60,000	2,420	1	0.02	±0.5	○

- The Moment of Inertia and Mass values are based on products with max. Inner diameter.
- Permissible Torque is the value regarding to a coupling's self-durability and is not related to slip-torque between the coupling bore and the shaft.
- Specially-designed split hubs are used for the size of 80C & 90C. (with 2 screws)

### Standard Inner Diameter (ID) 16C ~ 47C

Model	Standard Inner Diameter (d <sub>1</sub> , d <sub>2</sub> ) (mm)																					
	3	4	4.5	5	6	6.35	7	8	9	9.525	10	11	12	12.7	14	15	15.875	16	17	18	19	20
SDSS-16C	●	●	●	●																		
SDSS-19C		●	●	●	●																	
SDSS-22C		●	●	●	●	●	●	●	●	★												
SDSS-26C				●	●	●	●	●	●	●												
SDSS-31C					●	●	●	●	●	●	●	●	●	●	●	★	★					
SDSS-35C					●	●	●	●	●	●	●	●	●	●	●	●	●	●	★			
SDSS-39C							●	●	●	●	●	●	●	●	●	●	●	●				
SDSS-42C							●	●	●	●	●	●	●	●	●	●	●	●	●	●	★	★
SDSS-47C											●	●	●	●	●	●	●	●	●	●	●	★

- The recommended shaft tolerance is h7.
- Custom process (e.g. non-standard Inner diameter, special tolerance etc.) is also available upon a special request in prior to order placement.
- Keyway is available. (Optional)
- Due to interference of the middle parts, make sure the shaft is only inserted into L<sub>1</sub> depth for IDs with ★ mark. Consult us first if you're concerned about misalignment.

# SD SERIES (SDSS)

## Single Disk Type Coupling (Stainless Steel Body)

### Standard Inner Diameter (ID) 54C~90C

Model	Standard Inner Diameter ( $d_1, d_2$ ) (mm)																						
	10	11	12	12.7	14	15	15.875	16	17	18	19	20	22	24	25	26	28	30	32	35	40	45	
SDSS-54C	●	●	●	●	●	●	●	●	●	●	●	●	●	●	●★								
SDSS-64C			●	●	●	●	●	●	●	●	●	●	●	●	●★	●★	●★	●★	●★				
SDSS-80C						●	●	●	●	●	●	●	●	●	●	●	●	●	●	●★			
SDSS-90C												●	●	●	●	●	●	●	●	●	●	●	●★

- The recommended shaft tolerance is h7.
- Custom process (e.g. non-standard Inner diameter, special tolerance etc.) is also available upon a special request in prior to order placement.
- Keyway is available. (Optional)
- Due to interference of the middle parts, make sure the shaft is only inserted into L<sub>1</sub> depth for IDs with ★ mark. Consult us first if you're concerned about misalignment.
- Side-clamp Hub Split is available (Optional)

### Slip Torque

- The below table shows the actual permissible torque values when the slip torque value is lower than the coupling's permissible torque value.
- If the slip torque value is lower than the coupling's permissible torque value, please check and compare between the slip torque in the below table and the operating torque value of the connected motor. It is safer to size up the coupling or use a key/keyway when the slip torque value is lower than the motor's operating torque.
- The below slip torque values may be subject to change according to different testing conditions. (e.g. shaft tolerance, surface roughness, surface treatment or acceleration/deceleration of driving shafts). On the other hand, the values could be affected when a different kind of fastening screw is used (body material or surface treatment). Therefore, we recommend you test under the same conditions before mounting.
- The bigger sizes (OD ≥ 54) are recommended to have key/keyway in order to clamp the shaft firmly.

Model	Permissible Torque (N·m)	Slip Torque (N.m) by Inner Diameter ( $d_1, d_2$ )																					
		3	4	4.5	5	6	6.35	7	8	9	9.525	10	11	12	12.7	14	15	15.875	16	17	18	19	20
SDSS-16C	0.6	0.6																					
SDSS-19C	0.9		0.8																				
SDSS-22C	1.2		0.8	1.2	1.2																		
SDSS-26C	2.2				1.6	1.6	2	2															
SDSS-31C	4					1.3	1.4	2.5	2.7	3	3	3.5	4										
SDSS-35C	5					1	1	1.6	2.2	3	3	4	5										
SDSS-39C	6									3	3.5	3.5	3.8	4.2	5.5	6.4	8	9					
SDSS-39C(3)	9																						
SDSS-42C	8																						
SDSS-42C(3)	10								3.2	4	4.2	3	4.8	6	7	9.5	10	10					
SDSS-47C	14											3	4.9	6	6	8	8	9	9	9	14	14	

### Side-clamp Hub Split(W) Option is available

- From certain outer diameter(OD) sizes, we can provide Side-clamp Hub Split products.
- Please refer to "HOW TO ORDER" page for more details.



# SD SERIES (SDWS)

## Double Disk Type Coupling (Stainless Steel Body)

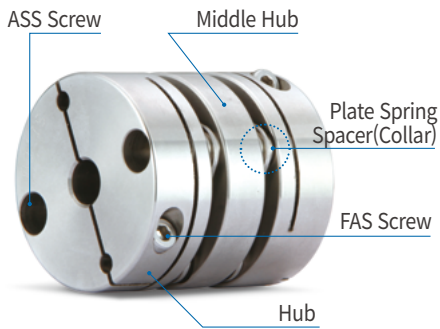

### Structure and Material

Structure	Material
Hub	Stainless Steel
Middle Hub	Stainless Steel
Plate Spring	Stainless Steel
Spacer(Collar)	Stainless Steel
Assembly Screw	STS304
Fastening Screw	STS304

### Product Features & Application

Backlash free (Precision)		☆
High Torque (Durability)		○
Torsional Stiffness		☆
Vibration Absorption		-
Misalignment Absorption		○
Corrosion resistance		☆
Applicable Motors	Servo	○
	Stepping	○
	Encoder	○
	General	-

**Application :** Semi-conductor manufacturing machine, SMT, Cartesian Robot, UVW Stage, Machine tools, Index Table, and Corrosion resistant / High-precision / High-heated environment

### Why Stainless Steel Products are recommended?

1. Corrosion Resistance allows to be used in rusty environment.
2. The heat resistance is better than aluminum alloy material's so that it keeps the mechanical properties of materials staying normal in high temperature applications.

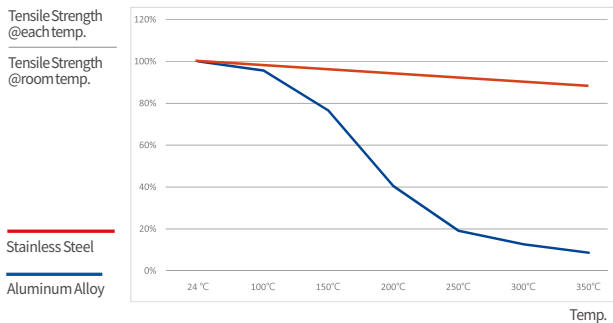

### Clamping Methods

Set-screw (No mark)	General	X
	With Keyway	X
Side-clamp (C)	General	○
	Hub Split	△
	With Keyway	○
Taper-ring (T)		X

※ You may check the sizes that Side-clamp Hub Split type is applicable from the "Dimensions / Performance" tables in the following pages.

### How to Order

**SDWS - 80 CW - 20 W K6 x 35 W K10**

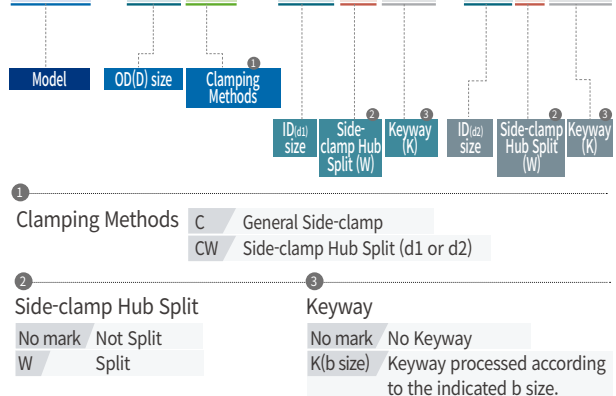

※ To verify the precise appearance of the product, please refer to the standard product drawing files provided on the top of our website's specification table or in the technical data section.

# SD SERIES (SDWS)

## Double Disk Type Coupling (Stainless Steel Body)

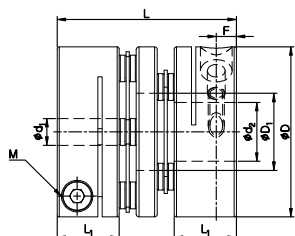

Size: 19C ~ 47C, 80C & 90C

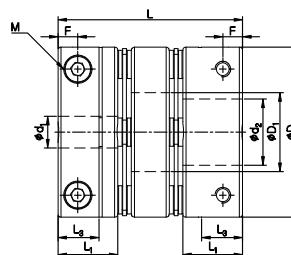

Size: 54C, 64C

### Dimensions / Performance

Model	Size (±0.3mm)						Screw		Permissible Torque (N·m)	Max. rpm (min <sup>-1</sup> )	Moment of Inertia (kg·m <sup>2</sup> )	Static Torsional Stiffness (N·m/rad)	Mass (g)	Permissible Misalignment		End-play (mm)	Side-clamp Hub Split (W)
	D	D <sub>1</sub>	L	L <sub>1</sub>	L <sub>3</sub>	F	Size	Fastening Torque (N·m)						Angular (°)	Parallel (mm)		
SDWAS-16C	16	6.3	21.2	7.8	-	2.5	M2	0.5	0.6	14,000	7.9×10 <sup>-7</sup>	200	22.4	1	0.05	±0.2	X
SDWBS-16C	16	6.3	23.2	7.8	-	2.5	M2	0.5	0.6	14,000	8.6×10 <sup>-7</sup>	200	24.3	1	0.05	±0.2	X
SDWAS-19C	19	8.4	23.3	8.7	-	2.9	M2.6	1	0.9	14,000	1.6×10 <sup>-6</sup>	300	37	1	0.05	±0.2	X
SDWBS-19C	19	8.4	26.3	8.7	-	2.9	M2.6	1	0.9	14,000	2.0×10 <sup>-6</sup>	300	39	1	0.05	±0.2	X
SDWAS-22C	22.2	9	25	8.7	-	2.8	M2.6	1	1.2	10,000	3.3×10 <sup>-6</sup>	400	47	1.5	0.12	±0.2	X
SDWBS-22C	22.2	9	27.2	8.7	-	2.8	M2.6	1	1.2	10,000	3.5×10 <sup>-6</sup>	400	50	1.5	0.12	±0.2	X
SDWAS-26C	26.6	12.2	32.5	10.6	-	3.4	M3	1.5	2.2	10,000	8.5×10 <sup>-6</sup>	600	92	1.5	0.15	±0.3	X
SDWAS-31C	31.8	14.4	33.5	11.6	-	3.7	M3	1.5	4	8,000	1.9×10 <sup>-5</sup>	1,300	140	1.5	0.15	±0.4	X
SDWBS-31C	31.8	14.4	38.5	11.6	-	3.7	M3	1.5	4	8,000	2.2×10 <sup>-5</sup>	1,300	162	1.5	0.15	±0.4	X
SDWAS-35C	35	16.2	34.6	12.7	-	4.4	M4	2.5	5	8,000	3.0×10 <sup>-5</sup>	1,500	165	1.5	0.16	±0.4	X
SDWCS-35C	35	16.2	38.1	12.7	-	4.4	M4	2.5	5	8,000	3.4×10 <sup>-5</sup>	1,500	198	1.5	0.16	±0.4	X
SDWAS-39C	39	17	39.5	13.7	-	4.3	M4	2.5	6	8,000	5.3×10 <sup>-5</sup>	1,800	257	1.5	0.18	±0.4	X
SDWAS-39C(3)	39	17	40.1	13.7	-	4.3	M4	2.5	9	8,000	5.3×10 <sup>-5</sup>	1,800	257	1.5	0.18	±0.4	X
SDWCS-39C	39	17	45	13.7	-	4.3	M4	2.5	6	8,000	6.0×10 <sup>-5</sup>	1,800	297	1.5	0.18	±0.4	X
SDWCS-39C(3)	39	17	45.6	13.7	-	4.3	M4	2.5	9	8,000	6.0×10 <sup>-5</sup>	1,800	297	1.5	0.18	±0.4	X
SDWCS-42C	42.5	18	46.2	13.7	-	4.3	M4	2.5	8	8,000	8.3×10 <sup>-5</sup>	2,000	324	1.5	0.18	±0.5	X
SDWCS-42C(3)	42.5	18	46.8	13.7	-	4.3	M4	2.5	10	8,000	8.3×10 <sup>-5</sup>	2,000	324	1.5	0.18	±0.5	X
SDWCS-47C	47	20.5	50	16	-	5.2	M4	2.5	14	7,500	1.4×10 <sup>-4</sup>	4,000	432	1.5	0.2	±0.5	X
SDWBS-54C	54	25	52.6	19	13	6.3	M5	4	25	7,500	2.8×10 <sup>-4</sup>	7,000	675	1.5	0.2	±0.5	○
SDWCS-54C	54	25	58.6	19	13	6.3	M5	4	25	7,500	3.0×10 <sup>-4</sup>	7,000	756	1.5	0.2	±0.5	○
SDWAS-64C	64	25.8	74.4	26	15.2	7.5	M6	8	40	6,500	6.8×10 <sup>-4</sup>	11,000	1,200	1.5	0.3	±0.5	○
SDWS-80C	80	35.8	81.8	29.7	19	9.4	M8	20	85	6,000	1.9×10 <sup>-3</sup>	20,000	2,020	2	0.4	±0.6	○
SDWCS-80C	80	35.8	98.3	29.7	19	9.4	M8	20	85	6,000	2.4×10 <sup>-3</sup>	20,000	2,490	2	0.5	±0.6	○
SDWS-90C	94.5	41.6	98.9	30.4	19	9.3	M8	20	180	6,000	4.5×10 <sup>-3</sup>	35,000	3,320	2	0.4	±0.8	○

- The Moment of Inertia and Mass values are based on products with max. Inner diameter.
- Permissible Torque is the value regarding to a coupling's self-durability and is not related to slip-torque between the coupling bore and the shaft.
- Specially-designed split hubs are used for the size of 80C & 90C. (with 2 screws)

### Standard Inner Diameter (ID) 16C ~ 47C

Model	Standard Inner Diameter (d <sub>1</sub> , d <sub>2</sub> ) (mm)																					
	3	4	4.5	5	6	6.35	7	8	9	9.525	10	11	12	12.7	14	15	15.875	16	17	18	19	20
SDW□S-16C	●	●	●	●																		
SDW□S-19C		●	●	●	●																	
SDW□S-22C		●	●	●	●	●	●	●	●★	●★												
SDW□S-26C			●	●	●	●	●	●	●	●	●	●	●	●	●	●	●	●	●	●	●	●
SDW□S-31C				●	●	●	●	●	●	●	●	●	●	●	●★	●★						
SDW□S-35C					●	●	●	●	●	●	●	●	●	●	●	●	●★	●★				
SDW□S-39C								●	●	●	●	●	●	●	●	●	●	●	●	●	●	●
SDW□S-42C								●	●	●	●	●	●	●	●	●	●	●	●	●	●★	●★
SDW□S-47C											●	●	●	●	●	●	●	●	●	●	●	●★

- The recommended shaft tolerance is h7.
- Custom process (e.g. non-standard Inner diameter, special tolerance etc.) is also available upon a special request in prior to order placement.
- Keyway is available. (Optional)
- Due to interference of the middle parts, make sure the shaft is only inserted into L<sub>1</sub> depth for IDs with ★ mark. Consult us first if you're concerned about misalignment.

# SD SERIES (SDWS)

## Double Disk Type Coupling (Stainless Steel Body)

### Standard Inner Diameter (ID) 54C ~ 90C

Model	Standard Inner Diameter (d <sub>1</sub> , d <sub>2</sub> ) (mm)																						
	10	11	12	12.7	14	15	15.875	16	17	18	19	20	22	24	25	26	28	30	32	35	40	45	
SDW□S-54C	●	●	●	●	●	●	●	●	●	●	●	●	●	●	●★								
SDW□S-64C			●	●	●	●	●	●	●	●	●	●	●	●	●★	●★	●★	●★	●★				
SDW□S-80C						●	●	●	●	●	●	●	●	●	●	●	●	●	●	●	●★		
SDW□S-90C												●	●	●	●	●	●	●	●	●	●	●	●★

- The recommended shaft tolerance is h7.
- Custom process (e.g. non-standard Inner diameter, special tolerance etc.) is also available upon a special request in prior to order placement.
- Keyway is available. (Optional)
- Due to interference of the middle parts, make sure the shaft is only inserted into L<sub>1</sub> depth for IDs with ★ mark. Consult us first if you're concerned about misalignment.
- Side-clamp Hub Split is available (Optional)

### Slip Torque

- The below table shows the actual permissible torque values when the slip torque value is lower than the coupling's permissible torque value.
- If the slip torque value is lower than the coupling's permissible torque value, please check and compare between the slip torque in the below table and the operating torque value of the connected motor. It is safer to size up the coupling or use a key/keyway when the slip torque value is lower than the motor's operating torque.
- The below slip torque values may be subject to change according to different testing conditions. (e.g. shaft tolerance, surface roughness, surface treatment or acceleration/deceleration of driving shafts). On the other hand, the values could be affected when a different kind of fastening screw is used (body material or surface treatment). Therefore, we recommend you test under the same conditions before mounting.
- The bigger sizes (OD ≥ 54) are recommended to have key/keyway in order to clamp the shaft firmly.

Model	Permissible Torque (N·m)	Slip Torque (N.m) by Inner Diameter (d <sub>1</sub> , d <sub>2</sub> )																					
		3	4	4.5	5	6	6.35	7	8	9	9.525	10	11	12	12.7	14	15	15.875	16	17	18	19	20
SDW□S-16C	0.6	0.6																					
SDW□S-19C	0.9		0.8																				
SDW□S-22C	1.2		0.8	1.2	1.2																		
SDW□S-26C	2.2				1.6	1.6	2	2															
SDW□S-31C	4					1.3	1.4	2.5	2.7	3	3	3.5	4										
SDW□S-35C	5					1	1	1.6	2.2	3	3	4	5										
SDW□S-39C	6									3	3.5	3.5	3.8	4.2	5.5	6.4	8	9					
SDW□S-39C(3)	9																						
SDW□S-42C	8									3.2	4	4.2	3	4.8	6	7	9.5	10	10				
SDW□S-42C(3)	10																						
SDW□S-47C	14											3	4.9	6	6	8	8	9	9	9	14	14	

### Side-clamp Hub Split(W) Option is available

- From certain outer diameter(OD) sizes, we can provide Side-clamp Hub Split products.
- Please refer to "HOW TO ORDER" page for more details.



# SAD SERIES



## Advanced Disk Coupling

### SAD vs SD

SAD Series is an advanced version of the general Disk type Coupling (SD series), with its plate-spring structure modified to make the coupling more durable and stiff. SAD series uses 3-point fixation method for its plate spring rather than 2-point as in general SD Series, which allows users to use smaller sized product but keep the similar performance level.

### 1. Advanced version of Plate Spring shape

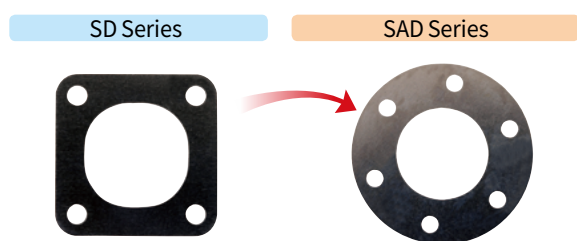

- The advanced plate spring with 6 assembly holes and these holes have narrower distance than 4-hole structure (SD series). Thus, SAD series is less flexible than SD series. On the other hand, increasing the number of assembly holes helps to disperse stress and it makes its module more durable and stiff. This advanced disk coupling is suitable for the purpose of enhanced performance, being able to replace similar small sized disk couplings.

### 2. Maximized Torque Transmission

The rated torque values (transmittable torque) of SAD series are higher compared to the similar sized general SD series.

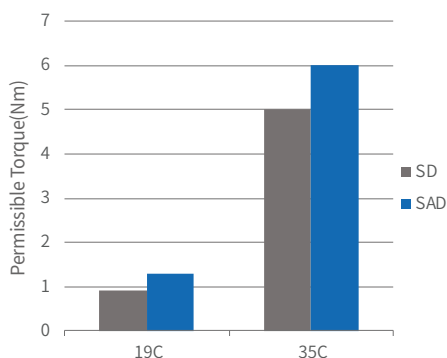

### 3. High Torsional Stiffness

SAD Series helps to obtain faster response time (excellent for high speed and high accuracy applications)

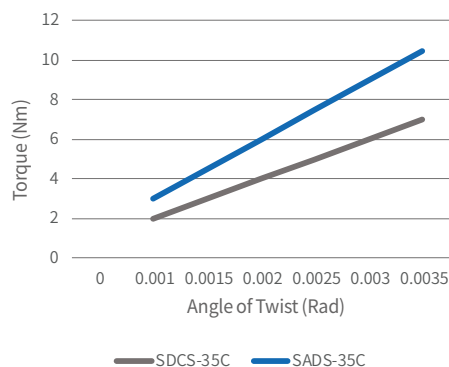

### Classification: SAD Series

Model	Type	Plate-spring Modules	Clamping Methods	Feature	Transmission level of Torque	Shape
SADS-C	Single Disk	1	Side-clamp	More stiff More durable	SADS-C = SADW-C Both types have higher level than similar sized SD series	
SADW-C	Double Disk	2		More flexible (compared to SADS-C)		

# SAD SERIES (SADS)

## Advanced Single Disk Type Coupling

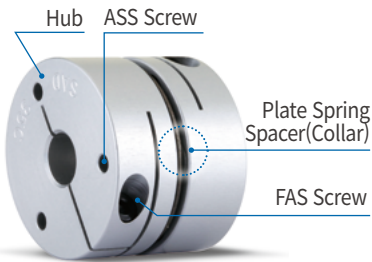

### Structure and Material

Structure	Material	Surface Treatment
Hub	High Strength Aluminum Alloy	Anodizing
Plate Spring	Stainless Steel	-
Spacer(Collar)	Steel	Black Oxide
Assembly Screw	SCM435	Black Oxide
Fastening Screw	SCM435	Black Oxide

### Product Features & Application

Backlash free (Precision)		☆
High Torque (Durability)		☆
Torsional Stiffness		☆
Vibration Absorption		-
Misalignment Absorption		△
Applicable Motors	Servo	☆
	Stepping	☆
	Encoder	○
	General	○

**Application :** Semi-conductor manufacturing machine, SMT, Cartesian Robot, UVW Stage, Machine tools, Index Table

### Parts with Alternative Material Options

- Sung-il Machinery provides alternative material options for Coupling parts for customers who are worried about corrosion on Black oxide finish. Please see the below table for more details.

Mark	Material	Surface Treatment
No mark	Steel	Black Oxide
SUS/ASS	Stainless Steel	-



No mark



SUS/ASS

- Caution: Slip torque would become lower if the body material or surface treatment of screws are changed from the standard version.

### Clamping Methods

Set-screw (No mark)	General	X
	With Keyway	X
Side-clamp (C)	General	○
	Hub Split	X
	With Keyway	○
Taper-ring (T)		X

### How to Order

**SADS - 35 C - 10 K3 x 14 K4**

Model    OD(D) size    Clamping Methods<sup>①</sup>    ID(d1) size    Keyway (K)<sup>②</sup>    ID(d2) size    Keyway (K)<sup>②</sup>

① Clamping Methods  
C General Side-clamp

② Keyway  
No mark No Keyway  
K(b size) Keyway processed according to the indicated b size.

※ To verify the precise appearance of the product, please refer to the standard product drawing files provided on the top of our website's specification table or in the technical data section.

# SAD SERIES (SADS)

## Advanced Single Disk Type Coupling

### Side-clamp

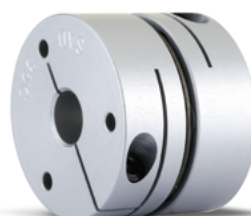
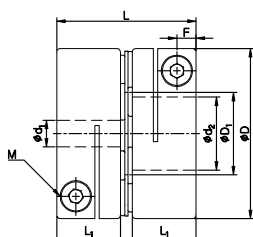

### Dimensions / Performance

Model	Size (±0.3mm)					Screw		Permissible Torque (N·m)	Max. rpm (min <sup>-1</sup> )	Moment of Inertia (kg·m <sup>2</sup> )	Static Torsional Stiffness (N·m/rad)	Mass (g)	Permissible Misalignment			Side-clamp Hub Split (W)
	D	D <sub>1</sub>	L	L <sub>1</sub>	F	Size	Fastening Torque (N·m)						Angular (°)	Parallel (mm)	End-play (mm)	
SADS-19C	19	8.5	18.8	8.5	2.6	M2	0.5	1.3	14,000	6.2×10 <sup>-7</sup>	800	12	1	0.02	±0.1	X
SADS-27C	27	14.5	24.2	11	3.3	M2.6	1	3	10,000	3.3×10 <sup>-6</sup>	1,800	28	1	0.02	±0.15	X
SADS-32C	32	15.5	26.2	12	3.6	M3	1.7	4.5	9,000	7.2×10 <sup>-6</sup>	2,800	46.4	1	0.02	±0.2	X
SADS-35C	35	16.5	27.2	12.5	3.8	M3	1.7	6	8,500	1.1×10 <sup>-5</sup>	3,000	58	1	0.02	±0.2	X
SADS-40C	40	20.5	33.2	15.5	4.5	M4	3.5	12	8,500	2.2×10 <sup>-5</sup>	5,500	90.1	1	0.02	±0.2	X
SADS-44C	44	22.5	33.2	15.5	4.5	M4	3.5	14	8,000	3.5×10 <sup>-5</sup>	7,500	112	1	0.02	±0.3	X

- The Moment of Inertia and Mass values are based on products with max. Inner diameter.
- Permissible Torque is the value regarding to a coupling's self-durability and is not related to slip-torque between the coupling bore and the shaft.

### Standard Inner Diameter (ID)

Model	Standard Inner Diameter (d <sub>1</sub> , d <sub>2</sub> ) (mm)																						
	3	4	4.5	5	6	6.35	7	8	9	9.525	10	11	12	12.7	14	15	15.875	16	17	18	19	20	22
SADS-19C	●	●	●	●	●	●	●	●★															
SADS-27C		●	●	●	●	●	●	●★	●	●	●	●	●	●★									
SADS-32C				●	●	●	●	●	●	●	●	●	●	●	●★								
SADS-35C				●	●	●	●	●	●	●	●	●	●	●	●	●★	●★						
SADS-40C					●	●	●	●	●	●	●	●	●	●	●	●	●	●	●	●	●	●★	
SADS-44C							●	●	●	●	●	●	●	●	●	●	●	●	●	●	●	●	●★

- The recommended shaft tolerance is h7.
- Custom process (e.g. non-standard Inner diameter, special tolerance etc.) is also available upon a special request in prior to order placement.
- The IDs with ★ mark may have structural limitations for additional keyway machining. Please contact customer service, especially if non-standard keyway dimensions are needed.
- Due to interference of the middle parts, make sure the shaft is only inserted into L<sub>1</sub> depth for IDs with ★ mark. Consult us first if you're concerned about misalignment.

### Slip Torque

- The below table shows the actual permissible torque values when the slip torque value is lower than the coupling's permissible torque value.
- If the slip torque value is lower than the coupling's permissible torque value, please check and compare between the slip torque in the below table and the operating torque value of the connected motor. It is safer to size up the coupling or use a key/keyway when the slip torque value is lower than the motor's operating torque.
- The below slip torque values may be subject to change according to different testing conditions. (e.g. shaft tolerance, surface roughness, surface treatment or acceleration/deceleration of driving shafts). On the other hand, the values could be affected when a different kind of fastening screw is used (body material or surface treatment). Therefore, we recommend you test under the same conditions before mounting.

Model	Permissible Torque (N·m)	Slip Torque (N.m) by Inner Diameter (d <sub>1</sub> , d <sub>2</sub> )														
		3	4	4.5	5	6	6.35	7	8	9	9.525	10	11	12	12.7	
SADS-19C	1.3	0.7	1.3													
SADS-27C	3		2.1	2.5	2.6	3										
SADS-32C	4.5				3.1	3.9	4.1	4.5								
SADS-35C	6				3.3	4.5										
SADS-40C	12					4.8	6.5	7.5	8.3	9	10.2					
SADS-44C	14								8	10	12	13				

# SAD SERIES (SADW)

## Advanced Double Disk Type Coupling

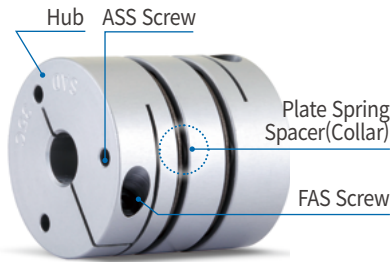

### Structure and Material

Structure	Material	Surface Treatment
Hub	High Strength Aluminum Alloy	Anodizing
Middle Hub	High Strength Aluminum Alloy	Anodizing
Plate Spring	Stainless Steel	-
Spacer(Collar)	Steel	Black Oxide
Assembly Screw	SCM435	Black Oxide
Fastening Screw	SCM435	Black Oxide

### Product Features & Application

Backlash free (Precision)	☆	
High Torque (Durability)	☆	
Torsional Stiffness	☆	
Vibration Absorption	-	
Misalignment Absorption	○	
Applicable Motors	Servo	☆
	Stepping	☆
	Encoder	○
	General	○

**Application :** Semi-conductor manufacturing machine, SMT, Cartesian Robot, UVW Stage, Machine tools, Index Table

### Parts with Alternative Material Options

- Sung-il Machinery provides alternative material options for Coupling parts for customers who are worried about corrosion on Black oxide finish. Please see the below table for more details.

Mark	Material	Surface Treatment
No mark	Steel	Black Oxide
SUS/ASS	Stainless Steel	-



No mark                      SUS/ASS

- Caution: Slip torque would become lower if the body material or surface treatment of screws are changed from the standard version.

### Clamping Methods

Set-screw (No mark)	General	X
	With Keyway	X
Side-clamp (C)	General	○
	Hub Split	X
	With Keyway	○
Taper-ring (T)		X

### How to Order

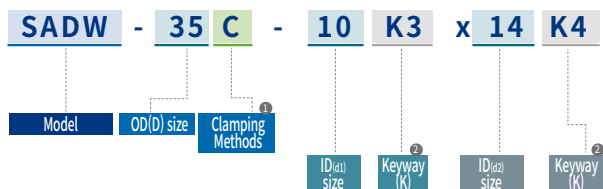

- Clamping Methods  
C General Side-clamp
- Keyway  
No mark No Keyway  
K(b size) Keyway processed according to the indicated b size.

※ To verify the precise appearance of the product, please refer to the standard product drawing files provided on the top of our website's specification table or in the technical data section.

# SAD SERIES (SADW)

## Advanced Double Disk Type Coupling

### Side-clamp

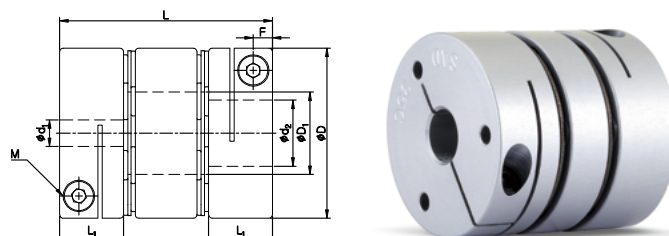

### Dimensions/Performance

Model	Size ( $\pm 0.3\text{mm}$ )					Screw		Permissible Torque (N·m)	Max. rpm ( $\text{min}^{-1}$ )	Moment of Inertia ( $\text{kg}\cdot\text{m}^2$ )	Static Torsional Stiffness (N·m/rad)	Mass (g)	Permissible Misalignment			Side-clamp Hub Split (W)
	D	D <sub>1</sub>	L	L <sub>1</sub>	F	Size	Fastening Torque (N·m)						Angular (°)	Parallel (mm)	End-play (mm)	
SADW-19C	19	8.5	26.6	8.5	2.6	M2	0.5	1.3	14,000	$9.1 \times 10^{-7}$	600	18	2	0.1	$\pm 0.2$	X
SADW-27C	27	14.5	34.4	11	3.3	M2.6	1	3	10,000	$4.8 \times 10^{-6}$	1,300	42	2	0.15	$\pm 0.3$	X
SADW-32C	32	15.5	40	12	3.6	M3	1.7	4.5	9,000	$1.1 \times 10^{-5}$	2,000	72.6	2	0.2	$\pm 0.4$	X
SADW-35C	35	16.5	37.4	12.5	3.8	M3	1.7	6	8,500	$1.5 \times 10^{-5}$	2,200	83	2	0.2	$\pm 0.4$	X
SADW-40C	40	20.5	46.9	15.5	4.5	M4	3.5	12	8,500	$3.3 \times 10^{-5}$	4,800	132.6	2	0.2	$\pm 0.4$	X
SADW-44C	44	22.5	46.9	15.5	4.5	M4	3.5	14	8,000	$5.0 \times 10^{-5}$	6,000	161	2	0.2	$\pm 0.6$	X

- The Moment of Inertia and Mass values are based on products with max. Inner diameter.
- Permissible Torque is the value regarding to a coupling's self-durability and is not related to slip-torque between the coupling bore and the shaft.

### Standard Inner Diameter (ID)

Model	Standard Inner Diameter ( $d_1, d_2$ ) (mm)																						
	3	4	4.5	5	6	6.35	7	8	9	9.525	10	11	12	12.7	14	15	15.875	16	17	18	19	20	22
SADW-19C	●	●	●	●	●	●	●	●★															
SADW-27C		●	●	●	●	●	●	●	●	●	●	●	●	●	●★								
SADW-32C				●	●	●	●	●	●	●	●	●	●	●	●	●★							
SADW-35C				●	●	●	●	●	●	●	●	●	●	●	●	●	●★	●★					
SADW-40C					●	●	●	●	●	●	●	●	●	●	●	●	●	●	●	●	●	●★	
SADW-44C								●	●	●	●	●	●	●	●	●	●	●	●	●	●	●	●★

- The recommended shaft tolerance is h7.
- Custom process (e.g. non-standard Inner diameter, special tolerance etc.) is also available upon a special request in prior to order placement.
- The IDs with ★ mark may have structural limitations for additional keyway machining. Please contact customer service, especially if non-standard keyway dimensions are needed.
- Due to interference of the middle parts, make sure the shaft is only inserted into L<sub>1</sub> depth for IDs with ★ mark. Consult us first if you're concerned about misalignment.

### Slip Torque

- The below table shows the actual permissible torque values when the slip torque value is lower than the coupling's permissible torque value.
- If the slip torque value is lower than the coupling's permissible torque value, please check and compare between the slip torque in the below table and the operating torque value of the connected motor. It is safer to size up the coupling or use a key/keyway when the slip torque value is lower than the motor's operating torque.
- The below slip torque values may be subject to change according to different testing conditions. (e.g. shaft tolerance, surface roughness, surface treatment or acceleration/deceleration of driving shafts). On the other hand, the values could be affected when a different kind of fastening screw is used (body material or surface treatment). Therefore, we recommend you test under the same conditions before mounting.

Model	Permissible Torque (N·m)	Slip Torque (N·m) by Inner Diameter ( $d_1, d_2$ )																					
		3	4	4.5	5	6	6.35	7	8	9	9.525	10	11	12	12.7								
SADW-19C	1.3	0.7	1.3																				
SADW-27C	3		2.1	2.5	2.6	3																	
SADW-32C	4.5					3.1	3.9	4.1	4.5														
SADW-35C	6					3.3	4.5																
SADW-40C	12						4.8	6.5	7.5	8.3	9	10.2											
SADW-44C	14										8	10	12	13									

# SHD SERIES



## High Torque Disk Coupling

### SHD vs SD

SHD Series is an advanced version of SD series with revised shape of its plate springs to disperse stress concentration and to enhance the stiffness and strength of the plate spring modules. In response to the advanced strength of SHD series, AL-7075-T6 material (Ultra high strength Aluminum Alloy) has been adopted as the body material to increase the overall durability.

#### 1. Advanced version of Plate Spring shape

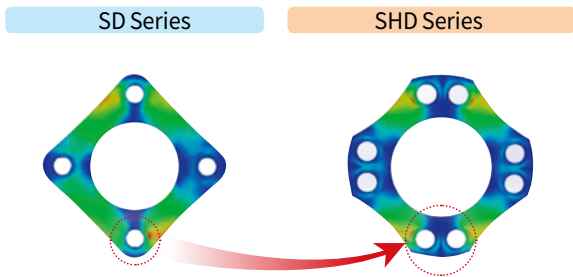

- Sung-il developed the improved version of plate spring with doubled assembly holes to disperse stress concentration, and it enhances both strength and stiffness to the higher extent.

#### 2. Improved durability with advanced body material

SD Series	AL2024
SHD Series	AL7075
	<b>Ratio (= AL7075 / AL2024)</b>
Yield Strength	1.7 ~ 1.8
Tensile Strength	1.3 ~ 1.4
Shearing Strength	1.15 ~ 1.2
Fatigue Strength	1.15 ~ 1.2

### Index

Clamping Methods		Set-screw		Side-clamp		Taper-ring
Size (OD)		56 ~ 110	126 ~ 144	50 ~ 110	126 ~ 144	56 ~ 110
Body Material		AL-7075-T6	Steel	AL-7075-T6	Steel	AL-7075-T6
Module	Single Disk (SHDS)					
	Double Disk (SHDW)					

# SHD SERIES (SHDS)

## Single Disk High Torque Disk Coupling

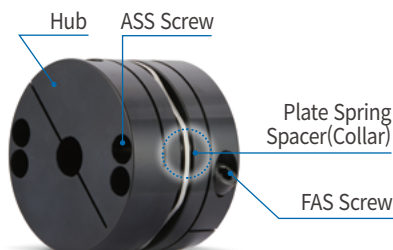

### Structure and Material - Size : 50 ~ 110

Structure	Material	Surface Treatment
Hub	Al-7075-T6	Anodizing
Plate Spring	Stainless Steel	-
Spacer(Collar)	Steel	Black Oxide
Assembly Screw	SCM435	Black Oxide
Fastening Screw	SCM435	Black Oxide

### Structure and Material - Size : 126 ~ 144

Structure	Material	Surface Treatment
Hub	Steel	Black Oxide (Standard)
Plate Spring	Stainless Steel	-
Spacer(Collar)	Steel	Black Oxide
Assembly Screw	SCM435	Black Oxide
Fastening Screw	SCM435	Black Oxide

※ Please contact Sung-il Customer Service team for eletroless nickel plating surface treatment option.

### Product Features & Application

Backlash free (Precision)		☆
High Torque (Durability)		☆
Torsional Stiffness		☆
Vibration Absorption		-
Misalignment Absorption		△
Applicable Motors	Servo	○
	Stepping	○
	Encoder	-
	General	○

**Application :** Cartesian Robot, Belt Drive, Machine tools, Index Table, Logistics facilities, Servo Press etc.

### Parts with Alternative Material Options

- Sung-il Machinery provides alternative material options for Coupling parts for customers who are worried about corrosion on Black oxide finish. Please see the below table for more details.

Mark	Material	Surface Treatment
No mark	Steel	Black Oxide
SUS/ASS	Stainless Steel	-



No mark



SUS/ASS

- Caution: Slip torque would become lower if the body material or surface treatment of screws are changed from the standard version.

### Clamping Methods

Set-screw (No mark)	General	△
	With Keyway	△
Side-clamp (C)	General	○
	Hub Split	○
	With Keyway	○
Taper-ring (T)		△

### How to Order

**SHDS - 56 CW - 20 W K6 x 25 W K8**

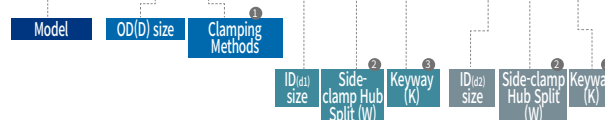

Clamping Methods	No mark	Set-screw
C	General Side-clamp	
CW	Side-clamp Hub Split	
T	Taper-ring	

Side-clamp Hub Split	No mark	Keyway
W	Not Split	No mark / No Keyway
	Split (Only applicable on Side-clamp Type)	K(b size) / Keyway processed according to the indicated b size. (Keyway is not applicable on Taper-ring type)

※ To verify the precise appearance of the product, please refer to the standard product drawing files provided on the top of our website's specification table or in the technical data section.

# SHD SERIES (SHDS)

## Single Disk High Torque Disk Coupling

### Set-Screw

#### Flange-shaped

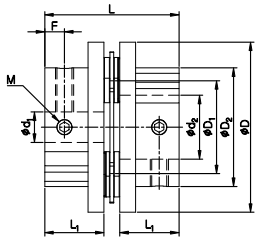

#### Cylinder-shaped

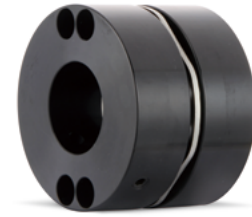
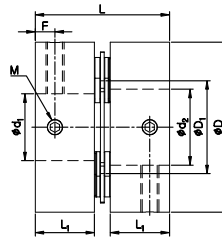

Size (OD)	56	66	88	110
Flange-shaped	< ID 22mm	< ID 26mm	< ID 32mm	< ID 48mm

Size (OD)	56	66	88	110
Cylinder-shaped	≥ ID 22mm	≥ ID 26mm	≥ ID 32mm	≥ ID 48mm

• Only flange-shaped products are available for OD126 and OD144

### Dimensions / Performance

Model	Size (±0.3mm)						Screw Size	Fastening Torque (N·m)	Permissible Torque (N·m)	Max. rpm (min <sup>-1</sup> )	Moment of Inertia (kg·m <sup>2</sup> )	Static Torsional Stiffness (N·m/rad)	Mass (g)	Permissible Misalignment		
	D	D <sub>1</sub>	D <sub>2</sub>	L	L <sub>1</sub>	F								Angular (°)	Parallel (mm)	End-play (mm)
SHDS-56	56	30.6	39	44.2	19.5	6.5	M6	7	35	7,700	2.9×10 <sup>-5</sup>	2.0×10 <sup>4</sup>	150	0.7	0.02	±0.3
SHDS-66	66	35.6	46	56.5	24.5	7.5	M8	15	60	7,000	8.0×10 <sup>-5</sup>	3.0×10 <sup>4</sup>	300	0.7	0.02	±0.3
SHDS-88	88	46	63	69.9	30	9.5	M8	15	180	5,500	2.9×10 <sup>-4</sup>	7.0×10 <sup>4</sup>	600	0.7	0.02	±0.3
SHDS-110	108	60.5	77	77.7	34.5	13	M10	30	280	4,000	2.0×10 <sup>-3</sup>	1.4×10 <sup>5</sup>	1,190	0.7	0.02	±0.5
SHDS-126	126	65	78/*92	91.2	40	12	M10	30	450	3,500	4.4×10 <sup>-3</sup>	4.4×10 <sup>5</sup>	3,200	1	0.02	±1.6
SHDS-144	144	75	88/*104	101.7	45	15	M10	30	600	3,000	8.4×10 <sup>-3</sup>	7.8×10 <sup>5</sup>	4,700	1	0.02	±1.8

- The Moment of Inertia and Mass values are based on products with max. Inner diameter.
- Permissible Torque is the value regarding to a coupling's self-durability and is not related to slip-torque between the coupling bore and the shaft. (Set-screw type is usually less durable than other clamping method, thus please consider it has a complementary option e.g. keyway along with.)
- OD 126 & 144: Please refer to \* marked values for D<sub>2</sub> when ID is over 55mm (OD126) and 66mm(OD144)

### Standard Inner Diameter (ID)

Model	Standard Inner Diameter (d <sub>1</sub> , d <sub>2</sub> ) (mm)																										
	10	11	12	14	15	16	18	19	20	22	24	25	26	28	30	32	35	38	40	42	45	48	50	55	60	65	70
SHDS-56	●	●	●	●	●	●	●	●	●	●	●																
SHDS-66					●	●	●	●	●	●	●	●	●	●	●	●											
SHDS-88									●	●	●	●	●	●	●	●	●	●	●	●	●						
SHDS-110															●	●	●	●	●	●	●	●	●	●	●	●	★
SHDS-126								●	●	●	●	●	●	●	●	●	●	●	●	●	●	●	●	●	●	●	
SHDS-144										●	●	●	●	●	●	●	●	●	●	●	●	●	●	●	●	●	●

- The recommended shaft tolerance is h7.
- Custom process (e.g. non-standard Inner diameter, special tolerance etc.) is also available upon a special request in prior to order placement.
- Keyway is available. (Optional)
- Due to interference of the middle parts, make sure the shaft is only inserted into L<sub>1</sub> depth for IDs with ★ mark. Consult us first if you're concerned about misalignment.

# SHD SERIES (SHDS)

## Single Disk High Torque Disk Coupling

### Side-clamp

| Cylinder-shaped |

| Flange-shaped (Low-inertia) |

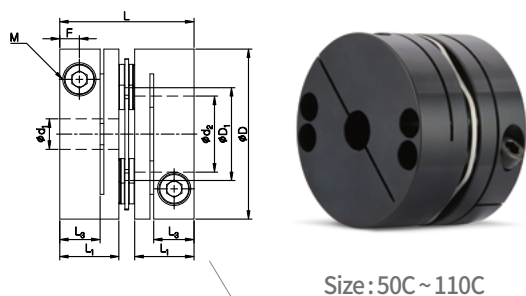

Size: 50C ~ 110C

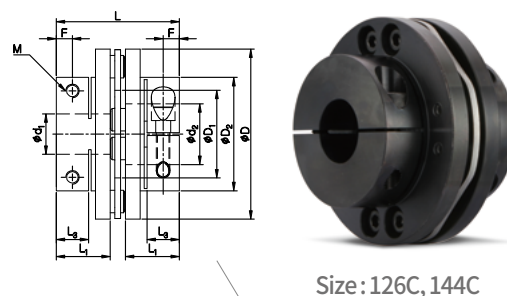

Size: 126C, 144C

### Dimensions / Performance

Model	Size (±0.3mm)							Screw Size	Fastening Torque (N·m)	Permissible Torque (N·m)	Max. rpm (min <sup>-1</sup> )	Moment of Inertia (kg·m <sup>2</sup> )	Static Torsional Stiffness (N·m/rad)	Mass (g)	Permissible Misalignment			Side-clamp Hub Split (W)
	D	D <sub>1</sub>	D <sub>2</sub>	L	L <sub>1</sub>	L <sub>3</sub>	F								Angular (°)	Parallel (mm)	End-play (mm)	
SHDS-50C	50	26.1	-	35.9	16.3	11	5.5	M5	8	25	7,500	5.3×10 <sup>-5</sup>	1.4×10 <sup>4</sup>	150	0.7	0.02	±0.3	○
SHDS-56C	56	30.6	-	44.2	19.5	13.3	6.5	M6	13	35	7,000	4.0×10 <sup>-5</sup>	2.0×10 <sup>4</sup>	210	0.7	0.02	±0.3	○
SHDS-66C	66	35.6	-	56.5	24.5	15.5	7.5	M6	13	60	6,500	1.0×10 <sup>-4</sup>	3.0×10 <sup>4</sup>	380	0.7	0.02	±0.3	○
SHDS-78C	78	41	-	60.5	27	17	8.5	M8	30	120	6,000	5.5×10 <sup>-4</sup>	5.0×10 <sup>4</sup>	584	0.7	0.02	±0.3	○
SHDS-88C	88	46	-	69.9	30	19	10	M8	30	180	5,500	9.5×10 <sup>-4</sup>	7.0×10 <sup>4</sup>	795	0.7	0.02	±0.3	○
SHDS-110C	108	60.5	-	77.7	34.5	21	10.5	M10	50	280	4,000	24.9×10 <sup>-4</sup>	1.4×10 <sup>5</sup>	1,320	0.7	0.02	±0.5	○
SHDS-126C	126	65	84/*100	91.2	40	24	12	M10	50	450	3,500	6.0×10 <sup>-3</sup>	4.4×10 <sup>5</sup>	4,000	1	0.02	±1.6	○
SHDS-144C	144	75	98/*110	101.7	45	28	14	M12	90	600	3,000	14.8×10 <sup>-3</sup>	7.8×10 <sup>5</sup>	5,500	1	0.02	±1.8	○

- The Moment of Inertia and Mass values are based on products with max. Inner diameter.
- Permissible Torque is the value regarding to a coupling's self-durability and is not related to slip-torque between the coupling bore and the shaft.
- For OD 126C & 144C products, please refer to D<sub>2</sub> values with \* mark when inner diameters are over 50mm.

### Standard Inner Diameter (ID)

Model	Standard Inner Diameter (d <sub>1</sub> , d <sub>2</sub> ) (mm)																										
	10	11	12	14	15	16	18	19	20	22	24	25	26	28	30	32	35	38	40	42	45	48	50	55	60	65	70
SHDS-50C	●	●	●	●	●	●	●	●	●	●																	
SHDS-56C	●	●	●	●	●	●	●	●	●	●	●																
SHDS-66C					●	●	●	●	●	●	●	●	●	●	●	●											
SHDS-78C							●	●	●	●	●	●	●	●	●	●	●	●	●								
SHDS-88C									●	●	●	●	●	●	●	●	●	●	●	●	●						
SHDS-110C																●	●	●	●	●	●	●	●	●	●	●	★
SHDS-126C																●	●	●	●	●	●	●	●	●	●	●	
SHDS-144C																	●	●	●	●	●	●	●	●	●	●	●

- The recommended shaft tolerance is h7.
- Custom process (e.g. non-standard Inner diameter, special tolerance etc.) is also available upon a special request in prior to order placement.
- Keyway is available. (Optional)
- Side-clamp Hub Split is available (Optional)
- Due to interference of the middle parts, make sure the shaft is only inserted into L<sub>1</sub> depth for IDs with ★ mark. Consult us first if you're concerned about misalignment.

# SHD SERIES (SHDS)

## Single Disk High Torque Disk Coupling

### Slip Torque

- The below table shows the actual permissible torque values when the slip torque value is lower than the coupling's permissible torque value.
- If the slip torque value is lower than the coupling's permissible torque value, please check and compare between the slip torque in the below table and the operating torque value of the connected motor. It is safer to size up the coupling or use a key/keyway when the slip torque value is lower than the motor's operating torque.
- The below slip torque values may be subject to change according to different testing conditions. (e.g. shaft tolerance, surface roughness, surface treatment or acceleration/deceleration of driving shafts). On the other hand, the values could be affected when a different kind of fastening screw is used (body material or surface treatment). Therefore, we recommend you test under the same conditions before mounting.

Model	Permissible Torque (N·m)	Slip Torque (N·m) by Inner Diameter (d <sub>1</sub> , d <sub>2</sub> )																									
		10	11	12	14	15	16	18	19	20	22	24	25	26	28	30	32	35	38	40	42	45	48	50	55	60	
SHDS-50C	25																										
SHDS-56C	35	30	30																								
SHDS-66C	60					45	50																				
SHDS-78C	120																										
SHDS-88C	180																										
SHDS-110C	280															162	170	182	199	221	235	247	253	273			
SHDS-126C	450															191	209	232	268	305	323	355	379	385	400	400	
SHDS-144C	600																										

### Side-clamp Hub Split(W) Option is available

- From certain outer diameter (OD) sizes, we can provide Side-clamp Hub Split products.
- Please refer to "HOW TO ORDER" page for more details.
- The no. of fastening screws for OD 50~110 products is only 1 each, however we provide 2 screws for Side-clamp Split (W) type according to the below drawing.

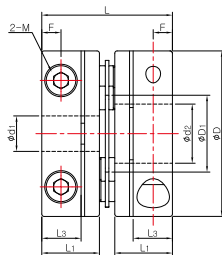

### Electroless Nickel Plating for Steel-body Products

- The standard surface treatment (finish) for steel-body product is **Black Oxide**.
- If corrosion is highly concerned, there is another surface treatment option of 'Electroless Nickel Plating' adding an additional code "NI" next to the part no. as shown below.

**SHDS - 126C - NI - 30 - 40**

- All other parts (collars, ASS screws and FAS screws) will be Electroless Nickel Plated as well.



- Caution: Slip torque would become lower if the body material or surface treatment of screws are changed from the standard version.

# SHD SERIES (SHDS)

## Single Disk High Torque Disk Coupling

### Taper-ring

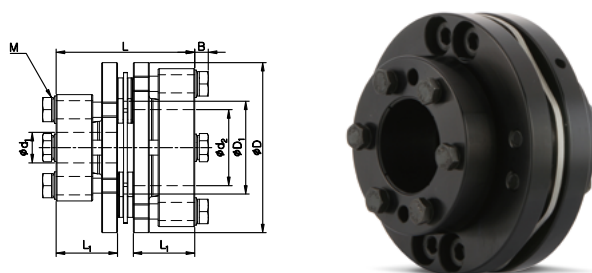

### Dimensions / Performance

Model	Size (±0.3mm)					Screw		Permissible Torque (N·m)	Max. rpm (min <sup>-1</sup> )	Moment of Inertia (kg·m <sup>2</sup> )	Static Torsional Stiffness (N·m/rad)	Mass (g)	Permissible Misalignment		
	D	D <sub>1</sub>	L	L <sub>1</sub>	B	Size	Fastening Torque (N·m)						Angular (°)	Parallel (mm)	End-play (mm)
SHDS-56T	56	30.6	45.6	20.2	4.5	M5	8	35	24,000	3.6×10 <sup>-5</sup>	2.0×10 <sup>4</sup>	190	0.7	0.02	±0.3
SHDS-66T	66	35.6	57.5	25	5	M6	13	60	20,000	8.6×10 <sup>-5</sup>	3.0×10 <sup>4</sup>	320	0.7	0.02	±0.3
SHDS-88T	88	46	69.9	30	5	M6	13	180	15,000	3.2×10 <sup>-4</sup>	7.0×10 <sup>4</sup>	670	0.7	0.02	±0.3
SHDS-110T	108	60.5	70.1	30.7	5	M6	13	280	12,000	1.6×10 <sup>-3</sup>	1.4×10 <sup>5</sup>	980	0.7	0.02	±0.5

- The Moment of Inertia and Mass values are based on products with max. Inner diameter.
- Due to the structure of Taper-ring, it's not allowed to have other complementary options to enhance clamping force such as keyway etc. This is the reason why the above-mentioned permissible torques are based on the slip torque at the min. standard inner diameter. (The bigger inner diameter, the higher permissible torque.)

### Standard Inner Diameter (ID)

Model	Standard Inner Diameter (d <sub>1</sub> , d <sub>2</sub> ) (mm)																								
	10	11	12	14	15	16	18	19	20	22	24	25	26	28	30	32	35	38	40	42	45	48	50	55	60
SHDS-56T	●	●	●	●	●	●	●	●	●	●	●														
SHDS-66T					●	●	●	●	●	●	●	●	●	●	●	●									
SHDS-88T									●	●	●	●	●	●	●	●	●	●	●	●	●	●			
SHDS-110T															●	●	●	●	●	●	●	●	●	●	★

- The recommended shaft tolerance is h7.
- Custom process (e.g. non-standard Inner diameter, special tolerance etc.) is also available upon a special request in prior to order placement.
- Keyway is **NOT** available
- Due to interference of the middle parts, make sure the shaft is only inserted into L<sub>1</sub> depth for IDs with ★ mark. Consult us first if you're concerned about misalignment.

### Slip Torque

- The below table shows the actual permissible torque values when the slip torque value is lower than the coupling's max. torque value.
- If the slip torque value is lower than the coupling's max. torque value, please check and compare between the slip torque in the below table and the operating torque value of the connected motor. It is safer to size up the coupling or use a key/keyway when the slip torque value is lower than the motor's operating torque.
- The below slip torque values may be subject to change according to different testing conditions. (e.g. shaft tolerance, surface roughness, surface treatment or acceleration/deceleration of driving shafts). On the other hand, the values could be affected when different kind of fastening screw is used. Therefore, we recommend you test under the same conditions before mounting.

Model	Permissible Torque (N·m)	Slip Torque (N.m) by Inner Diameter (d <sub>1</sub> , d <sub>2</sub> )																						
		10	11	12	14	15	16	18	19	20	22	24	25	26	28	30	32	35						
SHDS-56T	35																							
SHDS-66T	60																							
SHDS-88T	180									140	168	180												
SHDS-110T	280																			250	280			

# SHD SERIES (SHDW)

## Double Disk High Torque Disk Coupling

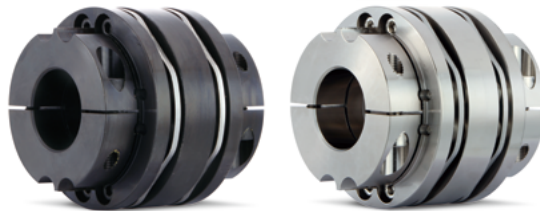
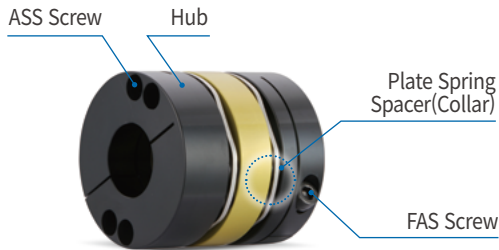

### Structure and Material Size : 50 ~ 110

Structure	Material	Surface Treatment
Hub	Al-7075-T6	Anodizing
Middle Hub	Al-7075-T6	
Plate Spring	Stainless Steel	-
Spacer(Collar)	Steel	Black Oxide
Assembly Screw	SCM435	Black Oxide
Fastening Screw	SCM435	Black Oxide

### Structure and Material Size : 126~144

Structure	Material	Surface Treatment
Hub	Steel	Black Oxide (Standard)
Middle Hub	Steel	
Plate Spring	Stainless Steel	-
Spacer(Collar)	Steel	Black Oxide
Assembly Screw	SCM435	Black Oxide
Fastening Screw	SCM435	Black Oxide

※ Please contact Sung-il Customer Service team for electroless nickel plating surface treatment option.

### Product Features & Application

Backlash free (Precision)		☆
High Torque (Durability)		☆
Torsional Stiffness		☆
Vibration Absorption		-
Misalignment Absorption		○
Applicable Motors	Servo	○
	Stepping	○
	Encoder	-
	General	○

**Application :** Cartesian Robot, Belt Drive, Machine tools, Index Table, Logistics facilities, Servo Press etc.

### Parts with Alternative Material Options

- Sung-il Machinery provides alternative material options for Coupling parts for customers who are worried about corrosion on Black oxide finish. Please see the below table for more details.

Mark	Material	Surface Treatment
No mark	Steel	Black Oxide
SUS/ASS	Stainless Steel	-

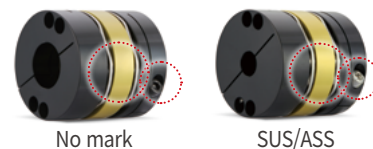

- Caution: Slip torque would become lower if the body material or surface treatment of screws are changed from the standard version.

### Clamping Methods

Set-screw (No mark)	General	△
	With Keyway	△
Side-clamp (C)	General	○
	Hub Split	○
	With Keyway	○
Taper-ring (T)		△

※ You may check the sizes that Side-clamp Hub Split type is applicable from the "Dimensions / Performance" tables in the following pages.

### How to Order

**SHDW - 56 CW - 20 W K6 x 25 W K8**

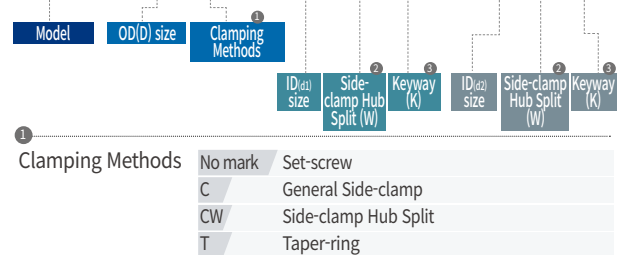

Clamping Methods	No mark	Set-screw
C	General Side-clamp	
CW	Side-clamp Hub Split	
T	Taper-ring	

Side-clamp Hub Split	No mark	Keyway
W	Not Split	No Keyway
	Split (Only applicable on Side-clamp Type)	K(b size) Keyway processed according to the indicated b size. (Keyway is not applicable on Taper-ring type)

※ To verify the precise appearance of the product, please refer to the standard product drawing files provided on the top of our website's specification table or in the technical data section.

# SHD SERIES (SHDW)

## Double Disk High Torque Disk Coupling

### Set-Screw

#### Flange-shaped

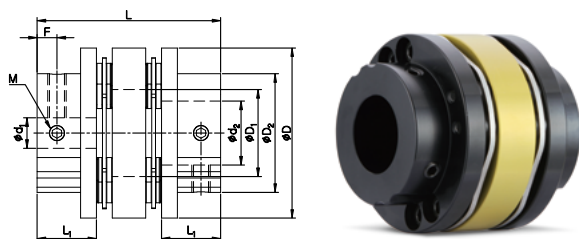

#### Cylinder-shaped

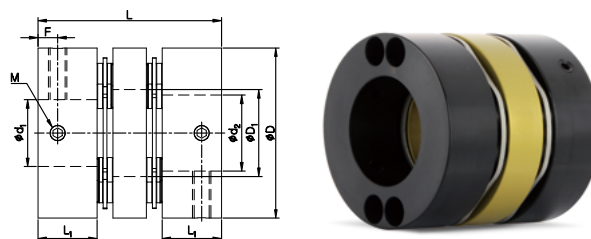

Size (OD)	56	66	88	110
Flange-shaped	< ID 22mm	< ID 26mm	< ID 32mm	< ID 48mm

Size (OD)	56	66	88	110
Cylinder-shaped	≥ ID 22mm	≥ ID 26mm	≥ ID 32mm	≥ ID 48mm

• Only flange-shaped products are available for OD126 and OD144

### Dimensions / Performance

Model	Size (±0.3mm)						Screw		Permissible Torque (N·m)	Max. rpm (min <sup>-1</sup> )	Moment of Inertia (kg·m <sup>2</sup> )	Static Torsional Stiffness (N·m/rad)	Mass (g)	Permissible Misalignment		
	D	D <sub>1</sub>	D <sub>2</sub>	L	L <sub>1</sub>	F	Size	Fastening Torque (N·m)						Angular (°)	Parallel (mm)	End-play (mm)
SHDW-56	56	28.6	39	60.4	19.5	6.5	M6	7	35	7,700	4.6×10 <sup>-5</sup>	1.0×10 <sup>4</sup>	240	1	0.2	±0.6
SHDW-66	66	35.6	46	80	24.5	7.5	M8	15	60	7,000	1.2×10 <sup>-4</sup>	1.5×10 <sup>4</sup>	440	1	0.2	±0.6
SHDW-88	88	46	63	99.8	30	9.5	M8	15	180	5,500	4.3×10 <sup>-4</sup>	3.5×10 <sup>4</sup>	900	1	0.2	±0.6
SHDW-110	108	60.5	77	111	34.5	13	M10	30	280	4,000	3.2×10 <sup>-3</sup>	7.0×10 <sup>4</sup>	1,750	1	0.25	±1
SHDW-126	126	65	78/*92	127.4	40	12	M10	30	450	3,500	1.0×10 <sup>-2</sup>	2.2×10 <sup>5</sup>	5,150	1	0.6	±3.2
SHDW-144	144	75	88/*104	143.4	45	15	M10	30	600	3,000	1.9×10 <sup>-2</sup>	3.9×10 <sup>5</sup>	7,600	1	0.6	±3.6

- The Moment of Inertia and Mass values are based on products with max. Inner diameter.
- Permissible Torque is the value regarding to a coupling's self-durability and is not related to slip-torque between the coupling bore and the shaft. (Set-screw type is usually less durable than other clamping method, thus please consider it has a complementary option e.g. keyway along with.)
- OD 126 & 144: Please refer to \* marked values for D2 when ID is over 55mm (OD126) and 66mm(OD144)

### Standard Inner Diameter (ID)

Model	Standard Inner Diameter (d <sub>1</sub> , d <sub>2</sub> ) (mm)																											
	10	11	12	14	15	16	18	19	20	22	24	25	26	28	30	32	35	38	40	42	45	48	50	55	60	65	70	
SHDW-56	●	●	●	●	●	●	●	●	●	●	●	●																
SHDW-66					●	●	●	●	●	●	●	●	●	●	●	●												
SHDW-88									●	●	●	●	●	●	●	●	●	●	●	●	●							
SHDW-110															●	●	●	●	●	●	●	●	●	●	●	●	●	★
SHDW-126								●	●	●	●	●	●	●	●	●	●	●	●	●	●	●	●	●	●	●	●	
SHDW-144										●	●	●	●	●	●	●	●	●	●	●	●	●	●	●	●	●	●	●

- The recommended shaft tolerance is h7.
- Custom process (e.g. non-standard Inner diameter, special tolerance etc.) is also available upon a special request in prior to order placement.
- Keyway is available. (Optional)
- Due to interference of the middle parts, make sure the shaft is only inserted into L<sub>1</sub> depth for IDs with ★ mark. Consult us first if you're concerned about misalignment.

# SHD SERIES (SHDW)

## Double Disk High Torque Disk Coupling

### Side-clamp

Cylinder-shaped

Flange-shaped (Low-inertia)

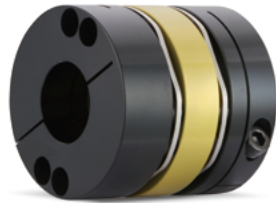
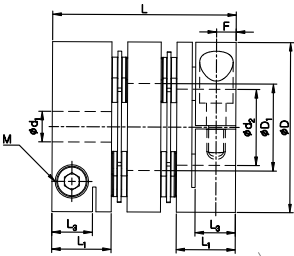

Size: 50C ~ 110C

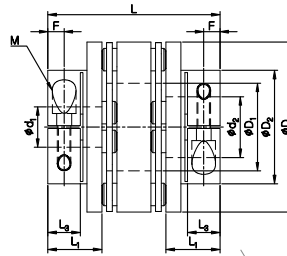

Size: 126C, 144C

### Dimensions / Performance

Model	Size (±0.3mm)							Screw		Permissible Torque (N·m)	Max. rpm (min <sup>-1</sup> )	Moment of Inertia (kg·m <sup>2</sup> )	Static Torsional Stiffness (N·m/rad)	Mass (g)	Permissible Misalignment			Side-clamp Hub Split (W)
	D	D <sub>1</sub>	D <sub>2</sub>	L	L <sub>1</sub>	L <sub>3</sub>	F	Size	Fastening Torque (N·m)						Angular (°)	Parallel (mm)	End-play (mm)	
SHDW-50C	50	24	-	50.2	16.3	11	5.5	M5	8	25	7,500	8.0×10 <sup>-5</sup>	8.5×10 <sup>3</sup>	220	1	0.2	±0.6	○
SHDW-56C	56	28.6	-	60.4	19.5	13.3	6.5	M6	13	35	7,000	5.8×10 <sup>-5</sup>	1.0×10 <sup>4</sup>	300	1	0.2	±0.6	○
SHDW-66C	66	35.6	-	80	24.5	15.5	7.5	M6	13	60	6,500	1.4×10 <sup>-4</sup>	1.5×10 <sup>4</sup>	520	1	0.2	±0.6	○
SHDW-78C	78	41	-	85	27	17	8.5	M8	30	120	6,000	7.9×10 <sup>-4</sup>	2.5×10 <sup>4</sup>	834	1	0.2	±0.6	○
SHDW-88C	88	46	-	99.8	30	19	10	M8	30	180	5,500	14.1×10 <sup>-4</sup>	3.5×10 <sup>4</sup>	1,170	1	0.2	±0.6	○
SHDW-110C	108	60.5	-	111	34.5	21	10.5	M10	50	280	4,000	37.6×10 <sup>-4</sup>	7.0×10 <sup>4</sup>	1,980	1	0.25	±1	○
SHDW-126C	126	65	84/*100	127.4	40	24	12	M10	50	450	3,500	1.3×10 <sup>-2</sup>	2.2×10 <sup>5</sup>	5,800	1	0.6	±3.2	○
SHDW-144C	144	75	98/*110	143.4	45	28	14	M12	90	600	3,000	25×10 <sup>-3</sup>	3.9×10 <sup>5</sup>	8,600	1	1	±3.6	○

- The Moment of Inertia and Mass values are based on products with max. Inner diameter.
- Permissible Torque is the value regarding to a coupling's self-durability and is not related to slip-torque between the coupling bore and the shaft.
- For OD 126C & 144C products, please refer to D2 values with \* mark when inner diameters are over 50mm.

### Standard Inner Diameter (ID)

Model	Standard Inner Diameter (d <sub>1</sub> , d <sub>2</sub> ) (mm)																											
	10	11	12	14	15	16	18	19	20	22	24	25	26	28	30	32	35	38	40	42	45	48	50	55	60	65	70	
SHDW-50C	●	●	●	●	●	●	●	●	●	●																		
SHDW-56C	●	●	●	●	●	●	●	●	●	●	●																	
SHDW-66C					●	●	●	●	●	●	●	●	●	●	●													
SHDW-78C							●	●	●	●	●	●	●	●	●	●	●	●	●									
SHDW-88C										●	●	●	●	●	●	●	●	●	●	●	●							
SHDW-110C																●	●	●	●	●	●	●	●	●	●	●	★	
SHDW-126C																●	●	●	●	●	●	●	●	●	●	●	●	
SHDW-144C																	●	●	●	●	●	●	●	●	●	●	●	

- The recommended shaft tolerance is h7.
- Custom process (e.g. non-standard Inner diameter, special tolerance etc.) is also available upon a special request in prior to order placement.
- Keyway is available. (Optional)
- Due to interference of the middle parts, make sure the shaft is only inserted into L<sub>1</sub> depth for IDs with ★ mark. Consult us first if you're concerned about misalignment.

# SHD SERIES (SHDW)

## Double Disk High Torque Disk Coupling

### Slip Torque

- The below table shows the actual permissible torque values when the slip torque value is lower than the coupling's permissible torque value.
- If the slip torque value is lower than the coupling's permissible torque value, please check and compare between the slip torque in the below table and the operating torque value of the connected motor. It is safer to size up the coupling or use a key/keyway when the slip torque value is lower than the motor's operating torque.
- The below slip torque values may be subject to change according to different testing conditions. (e.g. shaft tolerance, surface roughness, surface treatment or acceleration/deceleration of driving shafts). On the other hand, the values could be affected when different kind of fastening screw is used. Therefore, we recommend you test under the same conditions before mounting.

Model	Permissible Torque (N·m)	Slip Torque (N.m) by Inner Diameter ( $d_1, d_2$ )																									
		10	11	12	14	15	16	18	19	20	22	24	25	26	28	30	32	35	38	40	42	45	48	50	55	60	
SHDW-50C	25																										
SHDW-56C	35	30	30																								
SHDW-66C	60					45	50																				
SHDW-78C	120																										
SHDW-88C	180																										
SHDW-110C	280																162	170	182	199	221	235	247	253	273		
SHDW-126C	450																191	209	232	268	305	323	355	379	385	400	400
SHDW-144C	600																										

### Side-clamp Hub Split(W) Option is available

- From certain outer diameter (OD) sizes, we can provide Side-clamp Hub Split products.
- Please refer to "HOW TO ORDER" page for more details.
- The no. of fastening screws for OD 50~110 products is only 1 each, however we provide 2 screws for Side-clamp Split (W) type according to the below drawing.

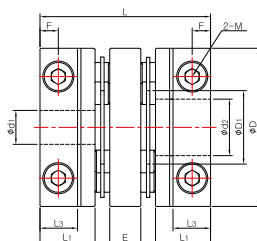

### Electroless Nickel Plating for Steel-body Products

- The standard surface treatment (finish) for steel-body product is **Black Oxide**.
- If corrosion is highly concerned, there is another surface treatment option of 'Electroless Nickel Plating' adding an additional code "NI" next to the part no. as shown below.

**SHDW - 126C - NI - 30 - 40**

- All other parts (collars, ASS screws and FAS screws) will be Electroless Nickel Plated as well.

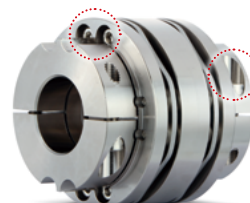

- Caution: Slip torque would become lower if the body material or surface treatment of screws are changed from the standard version.

# SHD SERIES (SHDW)

## Double Disk High Torque Disk Coupling

### Taper-ring

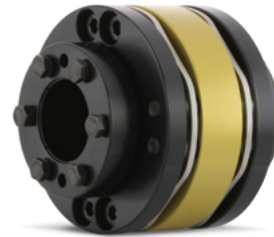
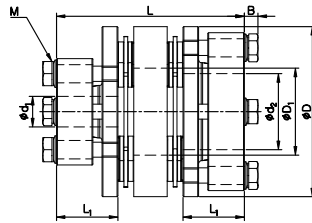

### Dimensions / Performance

Model	Size (±0.3mm)					Screw		Permissible Torque (N·m)	Max. rpm (min <sup>-1</sup> )	Moment of Inertia (kg·m <sup>2</sup> )	Static Torsional Stiffness (N·m/rad)	Mass (g)	Permissible Misalignment		
	D	D <sub>1</sub>	L	L <sub>1</sub>	B	Size	Fastening Torque (N·m)						Angular (°)	Parallel (mm)	End-play (mm)
SHDW-56T	56	28.6	61.8	20.2	4.5	M5	8	35	24,000	5.4×10 <sup>-5</sup>	1.0×10 <sup>4</sup>	280	1	0.2	±0.6
SHDW-66T	66	35.6	81	25	5	M6	13	60	20,000	1.2×10 <sup>-4</sup>	1.5×10 <sup>4</sup>	460	1	0.2	±0.6
SHDW-88T	88	46	99.8	30	5	M6	13	180	15,000	4.6×10 <sup>-4</sup>	3.5×10 <sup>4</sup>	970	1	0.2	±0.6
SHDW-110T	108	60.5	103.4	30.7	5	M6	13	280	12,000	3.7×10 <sup>-3</sup>	7.0×10 <sup>4</sup>	1,530	1	0.25	±1

- The Moment of Inertia and Mass values are based on products with max. Inner diameter.
- Due to the structure of Taper-ring, it's not allowed to have other complementary options to enhance clamping force such as keyway etc. This is the reason why the above-mentioned permissible torques are based on the slip torque at the min. standard inner diameter. (The bigger inner diameter, the higher permissible torque.)

### Standard Inner Diameter (ID)

Model	Standard Inner Diameter (d <sub>1</sub> , d <sub>2</sub> ) (mm)																								
	10	11	12	14	15	16	18	19	20	22	24	25	26	28	30	32	35	38	40	42	45	48	50	55	60
SHDW-56T	●	●	●	●	●	●	●	●	●	●	●	●													
SHDW-66T					●	●	●	●	●	●	●	●	●	●	●	●									
SHDW-88T									●	●	●	●	●	●	●	●	●	●	●	●	●	●	●	●	●
SHDW-110T															●	●	●	●	●	●	●	●	●	●	●★

- The recommended shaft tolerance is h7.
- Custom process (e.g. non-standard Inner diameter, special tolerance etc.) is also available upon a special request in prior to order placement.
- Keyway is **NOT** available
- Due to interference of the middle parts, make sure the shaft is only inserted into L<sub>1</sub> depth for IDs with ★ mark. Consult us first if you're concerned about misalignment.

### Slip Torque

- The below table shows the actual permissible torque values when the slip torque value is lower than the coupling's max. torque value.
- If the slip torque value is lower than the coupling's max. torque value, please check and compare between the slip torque in the below table and the operating torque value of the connected motor. It is safer to size up the coupling or use a key/keyway when the slip torque value is lower than the motor's operating torque.
- The below slip torque values may be subject to change according to different testing conditions. (e.g. shaft tolerance, surface roughness, surface treatment or acceleration/deceleration of driving shafts). On the other hand, the values could be affected when different kind of fastening screw is used. Therefore, we recommend you test under the same conditions before mounting.

Model	Permissible Torque (N·m)	Slip Torque (N·m) by Inner Diameter (d <sub>1</sub> , d <sub>2</sub> )																							
		10	11	12	14	15	16	18	19	20	22	24	25	26	28	30	32	35							
SHDW-56T	35																								
SHDW-66T	60																								
SHDW-88T	180									140	168	180													
SHDW-110T	280																					250	280		

## SCD SERIES



## Concentricity Disk Coupling

## SCD vs SD

SCD Series is an advanced version of the general Disk type Coupling (SD series), with its plate-spring structure and the hub shape modified to make the coupling more durable and stiff. This enhancement allows for more precise installation of the coupling and enables faster rotation.

## Advanced version of Plate Spring shape

SD Series

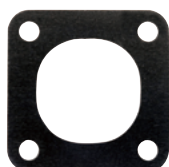

SCD Series



- The advanced plate spring with 6 assembly holes and these holes have narrower distance than 4-hole structure (SD series). Thus, SCD series is less flexible than SD series. On the other hand, increasing the number of assembly holes helps to disperse stress and it makes its module more durable and stiff. This advanced disk coupling is suitable for the purpose of enhanced performance, being able to replace similar sized disk couplings.

## How to Install

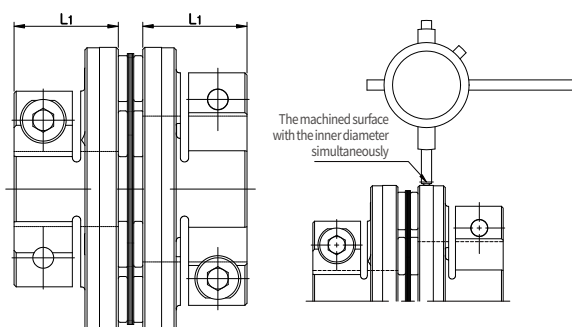

※ We recommend you only use the provided screws which are lubricated.

- Remove dust or oil substances from the surface of both the coupling and the shaft.
- Insert the shaft up to  $L_1$ . Make sure the plate spring doesn't get pressed by excessive force.
- After the shaft is inserted, pre-tighten two fastening screws alternately with limited torque, in order not to make it too loose.
- Place a dial gauge right on the surface which is machined with the inner diameter simultaneously (see figure), and fasten the screws alternately observing the gauge variation (run-out) is less than 0.02.
- Lastly, fasten the screws with full of fastening torque by using a torque wrench.
- Insert the opposite shaft while paying attention to the excessive force on the plate spring and fasten screws according to the above instruction.

## Classification: SCD Series

Model	Type	Plate-spring Modules	Clamping Methods	Feature	Transmission level of Torque	Shape
SCDS-C	Single Disk	1	Side-clamp	More stiff More durable	SCDS-C = SCDW-C Both types have higher level than similar sized SD series	
SCDW-C	Double Disk	2		More flexible (compared to SCDS-C)		

# SCD SERIES (SCDS)



## Concentricity Disk Coupling

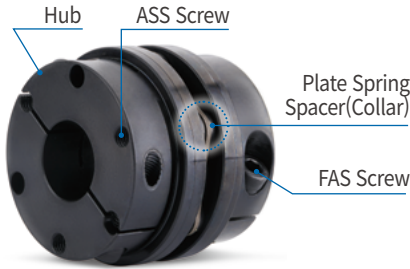

### Structure and Material

Structure	Material	Surface Treatment
Hub	Steel	Black Oxide
Plate Spring	Stainless Steel	-
Spacer(Collar)	Steel	Black Oxide
Assembly Screw	SCM435	Black Oxide
Fastening Screw	SCM435	Black Oxide

### Product Features & Application

Backlash free (Precision)	☆
High Torque (Durability)	☆
Torsional Stiffness	☆
Vibration Absorption	-
Misalignment Absorption	△

**Application :** Machine tools, Chip mounters, Cartesian Robot, Solar energy equipment

### Clamping Methods

Set-screw (No mark)	General	X
	With Keyway	X
Side-clamp (C)	General	○
	Hub Split	X
	With Keyway	X
Taper-ring (T)		X

### How to Order

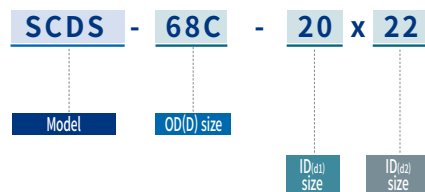

※ To verify the precise appearance of the product, please refer to the standard product drawing files provided on the top of our website's specification table or in the technical data section.

# SCD SERIES (SCDS)

## Concentricity Disk Coupling

### Side-clamp

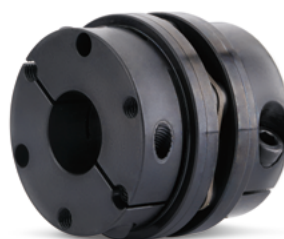
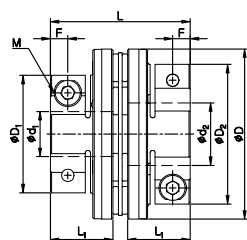

### Dimensions / Performance

Model	d <sub>1</sub> , d <sub>2</sub>	Size (±0.3mm)					Screw		Permissible Torque (N·m)	Max. rpm (min <sup>-1</sup> )	Moment of Inertia (kg·m <sup>2</sup> )	Static Torsional Stiffness (N·m/rad)	Mass (g)	Permissible Misalignment		
		D	D <sub>1</sub> , D <sub>2</sub>	L	L <sub>1</sub>	F	Size	Fastening Torque (N·m)						Angular (°)	Parallel (mm)	End-play (mm)
SCDS-68C	18 ~ 25	68	47	55.9	25	7	M6	14	90 / 100	18,000	0.42×10 <sup>-3</sup>	9.7×10 <sup>4</sup>	660	1	0.02	±0.5
	28 ~ 35		56													
SCDS-78C	22 ~ 26	78	52	67.7	30	8.5	M8	34	200	17,000	1.23×10 <sup>-3</sup>	2.1×10 <sup>5</sup>	1,400	1	0.02	±0.5
	28 ~ 35		70													
	38		74													
SCDS-88C	25 ~ 32	88	66	68.3	30	8.5	M8	34	250 / 300	15,000	1.6×10 <sup>-3</sup>	2.3×10 <sup>5</sup>	1,550	1	0.02	±0.5
	35 ~ 42		74													
SCDS-98C	32 ~ 48	98	84	90.2	40	12.5	M10	60	450	13,000	3.2×10 <sup>-3</sup>	3.0×10 <sup>5</sup>	2,510	1	0.02	±0.6
SCDS-118C	32 ~ 45	118	84	90.2	40	12.5	M10	60	520 / 600	11,000	6.8×10 <sup>-3</sup>	4.0×10 <sup>5</sup>	3,750	1	0.02	±0.8
	48 ~ 55		100													

- The Moment of Inertia and Mass values are based on products with max. Inner diameter.
- The permissible torque is determined by its inner diameter size. Please refer to the bottom of the page for more details.

### Standard Inner Diameter (ID)

Model	Permissible Torque (N·m)	Standard Inner Diameter (d <sub>1</sub> , d <sub>2</sub> ) (mm)																	
		18	19	20	22	24	25	26	28	30	32	35	38	40	42	45	48	50	55
SCDS-68C	90	●	●																
	100			●	●	●	●	●	●	●	●	●							
SCDS-78C	200				●	●	●	●	●	●	●	●							
SCDS-88C	250						●	●	●										
	300								●	●	●	●	●	●					
SCDS-98C	450									●	●	●	●	●	●				
SCDS-118C	520										●								
	600											●	●	●	●	●	●	●	●

- The recommended shaft tolerance is h7.
- Custom process (e.g. non-standard Inner diameter, special tolerance etc.) is also available upon a special request in prior to order placement.
- The permissible torque of a complete SCD coupling should be considered according to the smaller inner diameter's value.
- Keyway is NOT available for all sized SCD series.

# SCD SERIES (SCDW)



## Concentricity Disk Coupling

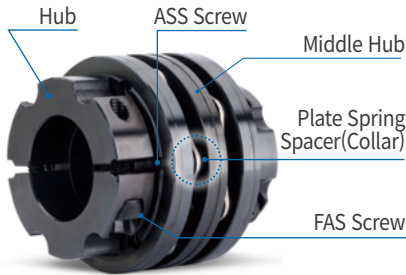

### Structure and Material

Structure	Material	Surface Treatment
Hub	Steel	Black Oxide
Middle Hub	Steel	Black Oxide
Plate Spring	Stainless Steel	-
Spacer(Collar)	Steel	Black Oxide
Assembly Screw	SCM435	Black Oxide
Fastening Screw	SCM435	Black Oxide

### Product Features & Application

Backlash free (Precision)	☆
High Torque (Durability)	☆
Torsional Stiffness	☆
Vibration Absorption	-
Misalignment Absorption	○

**Application :** Machine tools, Chip mounters, Cartesian Robot, Solar energy equipment

### Clamping Methods

Set-screw (No mark)	General	X
	With Keyway	X
Side-clamp (C)	General	○
	Hub Split	X
	With Keyway	X
Taper-ring (T)		X

### How to Order

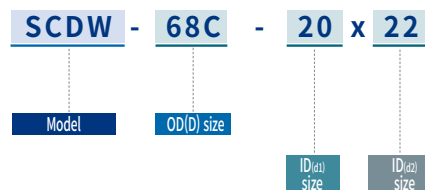

※ To verify the precise appearance of the product, please refer to the standard product drawing files provided on the top of our website's specification table or in the technical data section.

# SCD SERIES (SCDW)

## Concentricity Disk Coupling

### Side-clamp

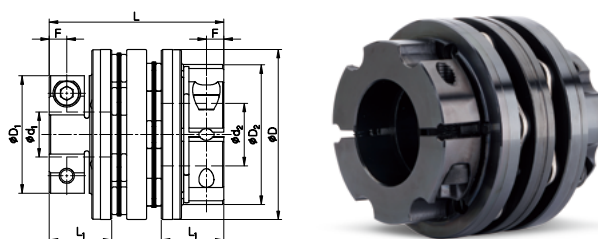

### Dimensions / Performance

Model	d <sub>1</sub> , d <sub>2</sub>	Size (±0.3mm)					Screw		Permissible Torque (N·m)	Max. rpm (min <sup>-1</sup> )	Moment of Inertia (kg·m <sup>2</sup> )	Static Torsional Stiffness (N·m/rad)	Mass (g)	Permissible Misalignment		
		D	D <sub>1</sub> , D <sub>2</sub>	L	L <sub>1</sub>	F	Size	Fastening Torque (N·m)						Angular (°)	Parallel (mm)	End-play (mm)
SCDW-68C	18~25	68	47	69.8	25	7	M6	14	90 / 100	14,000	0.54×10 <sup>-3</sup>	4.9×10 <sup>4</sup>	820	2	0.25	±1.0
	28~35		56													
SCDW-78C	22~25	78	52	85.4	30	8.5	M8	34	200	13,000	1.5×10 <sup>-3</sup>	1.0×10 <sup>5</sup>	1,700	2	0.3	±1.0
	28~35		70													
	38		74													
SCDW-88C	25~32	88	66	86.6	30	8.5	M8	34	250 / 300	12,000	2.1×10 <sup>-3</sup>	1.2×10 <sup>5</sup>	1,910	2	0.3	±1.2
	35~42		74													
SCDW-98C	32~48	98	84	112.4	40	12.5	M10	60	450	10,000	4.2×10 <sup>-3</sup>	1.5×10 <sup>5</sup>	3,130	2	0.3	±1.3
SCDW-118C	32~45	118	84	112.4	40	12.5	M10	60	520 / 600	9,000	8.6×10 <sup>-3</sup>	2.0×10 <sup>5</sup>	4,550	2	0.3	±1.6
	48~55		100													

- The Moment of Inertia and Mass values are based on products with max. Inner diameter.
- The permissible torque is determined by its inner diameter size. Please refer to the bottom of the page for more details.

### Standard Inner Diameter (ID)

Model	Permissible Torque (N·m)	Standard Inner Diameter (d <sub>1</sub> , d <sub>2</sub> ) (mm)																	
		18	19	20	22	24	25	26	28	30	32	35	38	40	42	45	48	50	55
SCDW-68C	90	●	●																
	100			●	●	●	●	●	●	●	●								
SCDW-78C	200				●	●	●	●	●	●	●	●							
SCDW-88C	250						●	●	●										
	300									●	●	●	●	●	●				
SCDW-98C	450										●	●	●	●	●	●			
SCDW-118C	520											●							
	600												●	●	●	●	●	●	●

- The recommended shaft tolerance is h7.
- Custom process (e.g. non-standard Inner diameter, special tolerance etc.) is also available upon a special request in prior to order placement.
- The permissible torque of a complete SCD coupling should be considered according to the smaller inner diameter's value.
- Keyway is NOT available for all sized SCD series.

# SJC SERIES



## Jaw Coupling



- Power transmission through the spider (sleeve) in the middle
- The highest durability comparing to other coupling series
- Various clamping methods available
- High precision with preloaded assembly

### Product Features & Application

Sleeve Material	Hytre	TPU
	(RD/GR)	(DG/BL)
Backlash free (Precision)	○	○
High Torque (Durability)	☆	☆
Torsional Stiffness	△	△
Vibration Absorption	△	○
Misalignment Absorption	△	△
Insulation of Electric Current	○	○
Applicable Motors	Servo	○
	Stepping	○
	Encoder	△
	General	☆
Permissible Temperature	-20°C ~ 120°C	-20°C ~ 70°C

**Application :** Machine tools, Press machine, Injection Molding machine, Pneumatic machine, Pump, Cartesian Robot, Belt Drive, Logistics facilities etc.

### Clamping Methods

Set-screw (No mark)	General	△
	With Keyway	△
Side-clamp (C)	General	○
	Hub Split	△
	With Keyway	○
Shaft-insertion (I)		△
Taper-ring (T)	General	△
	For High-Precision, High-Speed Spindles	△

※ △ symbol in the above table means that the availability is subject to differ according to each outer diameter size.

### HOW TO ORDER Set-screw / Side-clamp / Taper-ring

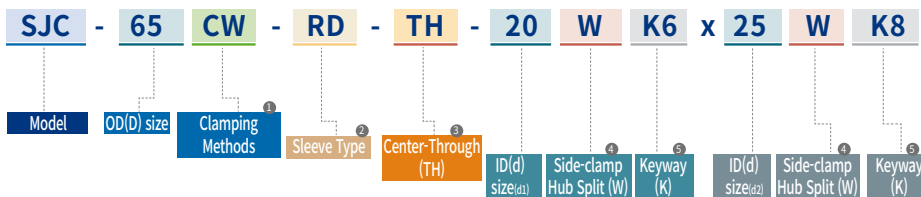

1	2	3	4	5
Clamping Methods	Sleeve Type (Shore Hardness)	Center-Through	Side-clamp Hub Split	Keyway
No mark Set-screw	RD Hytre, Sh63D	No mark Center-Solid	No mark Not Split	No mark No Keyway
C General Side-clamp	GR Hytre, Sh98A	TH Center-Through	W Split (Only applicable on Side-clamp Type)	K(b size) Keyway processed according to the indicated b size. (Keyway is not applicable on Taper-ring type)
CW Side-clamp Hub Split	DG TPU, Sh57D			
T Taper-ring	BL TPU, Sh98A			

※ For the taper-ring type (for high-precision / high-speed spindles), please refer to the product specification page.

# SJC SERIES

## Jaw Coupling

### Sleeve Material

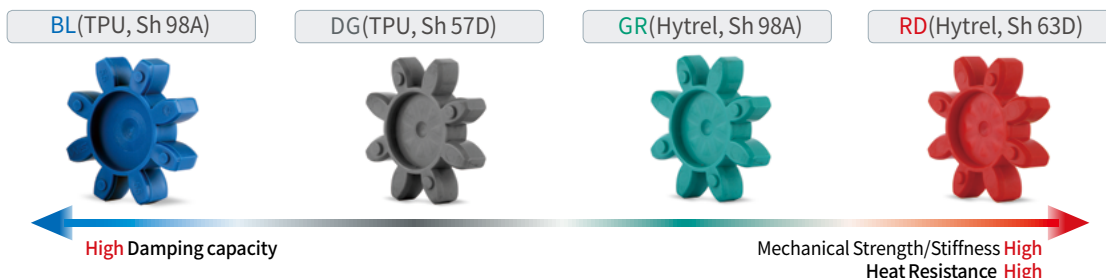

- A Sleeve (Spider) is the medium that transmits motion absorbing impact and misalignment and it is the core part of Jaw couplings.
- Hytrel® is superior in terms of **mechanical strength, abrasion resistance and heat resistance** whereas TPU (Thermoplastic polyurethane) has higher **damping capacity**.
- According to material and shore hardness, there are 4 types of sleeves, **RD**(Hytrel, Sh 63D), **GR**(Hytrel, Sh 98A), **DG**(TPU, Sh 57D), and **BL**(TPU, Sh 98A) respectively.

### Sleeve Types (General: Center-Solid / TH: Center-Through)

If the shaft has to be inserted deeper than  $L_1$  value, we can provide appropriate center-through sleeves. Please refer to “HOW TO ORDER” in the previous page. Either type has the identical value of transmittable torque and the same level of misalignment absorption. Due to the structural characteristics of the center-through (TH) type spacer, slight variations in static torsional stiffness values may occur.

Type	General : Center-Solid				TH : Center-Through				Model	Max. standard ID	Sleeve-TH ID
14-30	-				-				SJC-14	Φ5	-
	DG	BL	RD	GR	DG	BL	RD	GR	SJC-20	Φ8	Φ6
40	-				-				SJC-25	Φ10	Φ6.35
	DG	BL	RD	GR	DG	BL	RD	GR	SJC-30	Φ14	Φ8
48	-				-				SJC-40	Φ18	Φ15
	DG	BL	RD	GR	DG	BL	RD	GR	SJC-48	Φ28	Φ20
55-100									SJC-55	Φ28	Φ25
	DG	BL	RD	GR	DG	BL	RD	GR	SJC-65	Φ35	Φ25
120-135	-	-	-	-	-	-			SJC-80	Φ45	Φ32
	DG	BL	RD	GR	DG	BL	RD	GR	SJC-90	Φ50	Φ40
160	-	-	-	-	-	-			SJC-100	Φ60	Φ45
	DG	BL	RD	GR	DG	BL	RD	GR	SJC-120	Φ65	Φ55
160	-	-	-	-	-	-			SJC-135	Φ70	Φ65
	DG	BL	RD	GR	DG	BL	RD	GR	SJC-160	Φ80	Φ75

### Preload on Sleeves

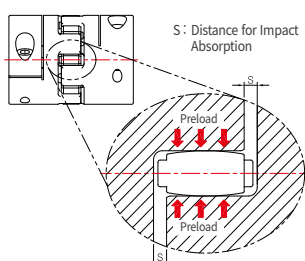

Sung-il's SJC Series is assembled with adequate preload and its outstanding features are as below.

1. Improved static torsional stiffness brings faster response
2. Minimized backlash as there is no clearance at the assembled area

Model	Distance S	Model	Distance S	Model	Distance S
SJC-14	1.0mm	SJC-40, 48, 55	2mm	SJC-100	3.5mm
SJC-20	1.0mm	SJC-65	2.5mm	SJC-120	4mm
SJC-25	1.2mm	SJC-80	3mm	SJC-135	4.5mm
SJC-30	1.5mm	SJC-90	3mm	SJC-160	5mm

# SJC SERIES

## Jaw Coupling

Performance table according to sleeve types

Model	Code	Material	Shore Hardness	Rated Torque (N·m)	Max. Torque (N·m)	Static Torsional Stiffness (N·m/rad)	Permissible Misalignment		
							Angular (°)	Parallel (mm)	End-play (mm)
SJC-14	BL	TPU	98A	2	4	22	1	0.05	-0.2 ~ +0.6
	GR	Hytrel	98A	2	4	25	1	0.05	-0.2 ~ +0.6
	RD	Hytrel	63D	2.5	5	34	1	0.03	-0.2 ~ +0.6
SJC-20	BL	TPU	98A	4	8	50	1	0.07	-0.3 ~ +0.8
	GR	Hytrel	98A	4	8	60	1	0.07	-0.3 ~ +0.8
	RD	Hytrel	63D	6	12	74	1	0.05	-0.3 ~ +0.8
SJC-25	BL	TPU	98A	9	18	220	1	0.07	-0.4 ~ +1.0
	GR	Hytrel	98A	9	18	260	1	0.07	-0.4 ~ +1.0
	RD	Hytrel	63D	12	24	300	1	0.05	-0.4 ~ +1.0
SJC-30	BL	TPU	98A	12	24	170	1	0.08	-0.5 ~ +1.0
	GR	Hytrel	98A	12	24	200	1	0.08	-0.5 ~ +1.0
	RD	Hytrel	63D	16	32	220	1	0.06	-0.5 ~ +1.0
SJC-40	BL	TPU	98A	17	34	1,500	1	0.06	-0.6 ~ +1.2
	GR	Hytrel	98A	17	34	1,600	1	0.06	-0.6 ~ +1.2
	RD	Hytrel	63D	21	42	1,750	1	0.04	-0.6 ~ +1.2
SJC-48	BL	TPU	98A	35	70	1,800	1	0.08	-0.6 ~ +1.3
	GR	Hytrel	98A	35	70	2,800	1	0.08	-0.6 ~ +1.3
	RD	Hytrel	63D	40	80	3,600	1	0.05	-0.6 ~ +1.3
SJC-55	BL	TPU	98A	60	120	3,000	1	0.09	-0.6 ~ +1.4
	DG	TPU	57D	60	120	4,500	1	0.08	-0.6 ~ +1.4
	GR	Hytrel	98A	60	120	4,500	1	0.09	-0.6 ~ +1.4
	RD	Hytrel	63D	75	150	6,000	1	0.06	-0.6 ~ +1.4
SJC-65	BL	TPU	98A	150	300	6,500	1	0.1	-0.6 ~ +1.5
	DG	TPU	57D	150	300	8,500	1	0.09	-0.6 ~ +1.5
	GR	Hytrel	98A	150	300	8,500	1	0.1	-0.6 ~ +1.5
	RD	Hytrel	63D	180	360	10,000	1	0.08	-0.6 ~ +1.5
SJC-80	BL	TPU	98A	300	600	8,000	1	0.1	-0.6 ~ +1.5
	DG	TPU	57D	300	600	12,000	1	0.09	-0.6 ~ +1.5
	GR	Hytrel	98A	300	600	12,000	1	0.1	-0.6 ~ +1.5
	RD	Hytrel	63D	380	760	14,000	1	0.08	-0.6 ~ +1.5
SJC-90	BL	TPU	98A	450	900	12,000	1	0.15	-0.6 ~ +2.0
	DG	TPU	57D	450	900	14,000	1	0.12	-0.6 ~ +2.0
	GR	Hytrel	98A	450	900	14,000	1	0.15	-0.6 ~ +2.0
	RD	Hytrel	63D	500	1,000	16,000	1	0.1	-0.6 ~ +2.0
SJC-100	BL	TPU	98A	500	1,000	24,000	1	0.15	-0.6 ~ +2.0
	DG	TPU	57D	500	1,000	24,000	1	0.12	-0.6 ~ +2.0
	GR	Hytrel	98A	500	1,000	30,000	1	0.15	-0.6 ~ +2.0
	RD	Hytrel	63D	600	1,200	40,000	1	0.1	-0.6 ~ +2.0
SJC-120	GR	Hytrel	98A	620	1,240	50,000	0.9	0.16	-1.0 ~ +2.2
	RD	Hytrel	63D	740	1,480	90,000	0.8	0.11	-1.0 ~ +2.2
SJC-135	GR	Hytrel	98A	850	1,700	60,000	0.9	0.17	-1.0 ~ +2.2
	RD	Hytrel	63D	1,050	2,100	100,000	0.8	0.12	-1.0 ~ +2.2
SJC-160	GR	Hytrel	98A	1,700	3,400	90,000	0.9	0.2	-1.5 ~ +3.0
	RD	Hytrel	63D	2,100	4,200	150,000	0.8	0.14	-1.5 ~ +3.0

## SJC SERIES



## Jaw Coupling

## Structure and Material of SJC Series

## Set-screw Size : 14 ~ 100



Structure	Material	Surface Treatment
Hub	High Strength Aluminum Alloy	Anodizing
Sleeve	Hytrel®(RD/GR) TPU (DG/BL)	-
Screw	SCM435	Black Oxide

## Side-clamp Size : 14C ~ 100C



Structure	Material	Surface Treatment
Hub	High Strength Aluminum Alloy	Anodizing
Sleeve	Hytrel®(RD/GR) TPU (DG/BL)	-
Screw	SCM435	Black Oxide

## Side-clamp Size : 120C ~ 160C



Structure	Material	Surface Treatment
Hub	Steel	Electroless Nickel Plating
Sleeve	Hytrel®(RD/GR)	-
Screw	SCM435	Electroless Nickel Plating

## Side-clamp (Space-saving) Size : M-55C ~ M-100C



Structure	Material	Surface Treatment
Hub	High Strength Aluminum Alloy	Anodizing
Sleeve	Hytrel®(RD/GR) TPU (DG/BL)	-
Screw	SCM435	Black Oxide

## Shaft-insertion Size : 25I ~ 65I



Structure	Material	Surface Treatment
Hub	High Strength Aluminum Alloy	Anodizing
Sleeve	Hytrel®(RD/GR) TPU (DG/BL)	-
Bushing	Stainless Steel	
Screw	SCM435	Black Oxide

## Taper-ring Size : 55T ~ 100T



Structure	Material	Surface Treatment
Hub	High Strength Aluminum Alloy	Anodizing
Sleeve	Hytrel®(RD/GR) TPU (DG/BL)	-
Screw	SCM435	Black Oxide

## Taper ring type coupling (for high-precision / high-speed spindles) Size : 55T ~ 100T



Structure	Material	Surface Treatment
Hub	Steel	-
Sleeve	Hytrel®(RD/GR) TPU (DG/BL)	-
Screw	SCM435	Black Oxide

※ Taper ring type coupling (for high-precision / high-speed spindles) is supplied as made-to-order. Hub and screw materials and surface treatments may vary depending on operating conditions.

# SJC SERIES

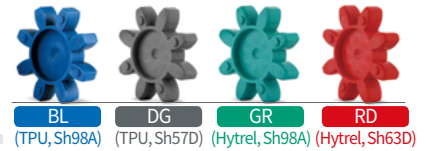

## Jaw Coupling

### Set-screw

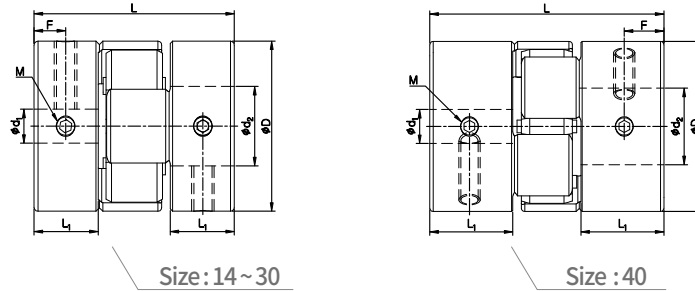

### Dimensions/Performance

Model	Size ( $\pm 0.3\text{mm}$ )				Screw		Rated Torque (N·m)	Max. Torque (N·m)	Max. rpm (min <sup>-1</sup> )	Moment of Inertia (kg·m <sup>2</sup> )	Static Torsional Stiffness (N·m/rad)	Mass (g)	Permissible Misalignment		
	D	L	L <sub>1</sub>	F	Size	Fastening Torque (N·m)							Angular (°)	Parallel (mm)	End-play (mm)
SJC-14-BL	14	22	7	3.5	M3	0.7	2	4	27,000	$2.1 \times 10^{-7}$	22	6.7	1	0.05	-0.2 ~ +0.6
SJC-14-GR	14	22	7	3.5	M3	0.7	2	4	27,000	$2.1 \times 10^{-7}$	25	6.7	1	0.05	-0.2 ~ +0.6
SJC-14-RD	14	22	7	3.5	M3	0.7	2.5	5	27,000	$2.1 \times 10^{-7}$	34	6.7	1	0.03	-0.2 ~ +0.6
SJC-20-BL	20	30	10	4.7	M3	0.7	4	8	19,000	$1.0 \times 10^{-6}$	50	18.3	1	0.07	-0.3 ~ +0.8
SJC-20-GR	20	30	10	4.7	M3	0.7	4	8	19,000	$1.0 \times 10^{-6}$	60	18.3	1	0.07	-0.3 ~ +0.8
SJC-20-RD	20	30	10	4.7	M3	0.7	6	12	19,000	$1.0 \times 10^{-6}$	74	18.3	1	0.05	-0.3 ~ +0.8
SJC-25-BL	25	31.3	10	5	M4	1.7	9	18	15,000	$2.7 \times 10^{-6}$	220	30	1	0.07	-0.4 ~ +1.0
SJC-25-GR	25	31.3	10	5	M4	1.7	9	18	15,000	$2.7 \times 10^{-6}$	260	30	1	0.07	-0.4 ~ +1.0
SJC-25-RD	25	31.3	10	5	M4	1.7	12	24	15,000	$2.7 \times 10^{-6}$	300	30	1	0.05	-0.4 ~ +1.0
SJCA-30-BL	30	35.3	11.3	5.6	M4	1.7	12	24	13,000	$6.2 \times 10^{-6}$	170	46	1	0.08	-0.4 ~ +1.0
SJCA-30-GR	30	35.3	11.3	5.6	M4	1.7	12	24	13,000	$6.2 \times 10^{-6}$	200	46	1	0.08	-0.4 ~ +1.0
SJCA-30-RD	30	35.3	11.3	5.6	M4	1.7	16	32	13,000	$6.2 \times 10^{-6}$	220	46	1	0.06	-0.4 ~ +1.0
SJCB-30-BL	30	44.7	16	7.3	M4	1.7	12	24	13,000	$8.2 \times 10^{-6}$	170	60	1	0.08	-0.4 ~ +1.0
SJCB-30-GR	30	44.7	16	7.3	M4	1.7	12	24	13,000	$8.2 \times 10^{-6}$	200	60	1	0.08	-0.4 ~ +1.0
SJCB-30-RD	30	44.7	16	7.3	M4	1.7	16	32	13,000	$8.2 \times 10^{-6}$	220	60	1	0.06	-0.4 ~ +1.0
SJCA-40-BL	40	55	19.5	9.3	M5	4	17	34	9,600	$3.3 \times 10^{-5}$	1,500	132	1	0.06	-0.5 ~ +1.2
SJCA-40-GR	40	55	19.5	9.3	M5	4	17	34	9,600	$3.3 \times 10^{-5}$	1,600	132	1	0.06	-0.5 ~ +1.2
SJCA-40-RD	40	55	19.5	9.3	M5	4	21	42	9,600	$3.3 \times 10^{-5}$	1,750	132	1	0.04	-0.5 ~ +1.2
SJCB-40-BL	40	66	25	11.6	M5	4	17	34	9,600	$4.0 \times 10^{-5}$	1,500	163	1	0.06	-0.5 ~ +1.2
SJCB-40-GR	40	66	25	11.6	M5	4	17	34	9,600	$4.0 \times 10^{-5}$	1,600	163	1	0.06	-0.5 ~ +1.2
SJCB-40-RD	40	66	25	11.6	M5	4	21	42	9,600	$4.0 \times 10^{-5}$	1,750	163	1	0.07	-0.5 ~ +1.2

- The Moment of Inertia and Mass values are based on products with max. Inner diameter.
- Please modify rated/max. torque value with temperature correction factor when it's higher than 30°C.
- Max. torque/rated torque is the value regarding to a coupling's self-durability and is not related to slip-torque between the coupling bore and the shaft. (Set-screw type is usually less durable than other clamping method, thus please consider it has a complementary option e.g. keyway along with.)

### Standard Inner Diameter (ID)

Model	Standard Inner Diameter (d <sub>1</sub> , d <sub>2</sub> ) (mm)																
	3	4	4.5	5	6	6.35	7	8	9	9.525	10	11	12	14	15	16	18
SJC□-14	●	●	●	●													
SJC□-20		●	●	●	●	●	●	●									
SJC□-25				●	●	●	●	●	●	●	●						
SJC□-30					●	●	●	●	●	●	●	●	●	●			
SJC□-40							●	●	●	●	●	●	●	●	●	●	●

- The recommended shaft tolerance is h7.
- Custom process (e.g. non-standard Inner diameter, special tolerance etc.) is also available upon a special request in prior to order placement.
- Keyway is available. (Optional)

# SJC SERIES

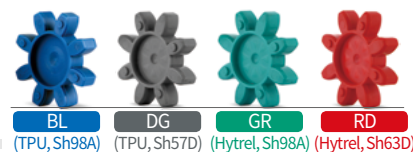

## Jaw Coupling

### Set-screw

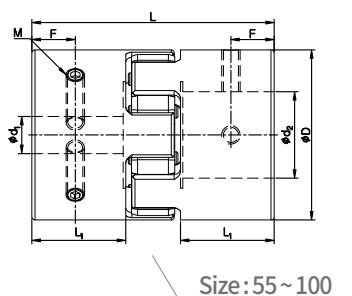

### Dimensions / Performance

Model	Size ( $\pm 0.3\text{mm}$ )				Screw Size	Fastening Torque (N·m)	Rated Torque (N·m)	Max. Torque (N·m)	Max. rpm ( $\text{min}^{-1}$ )	Moment of Inertia ( $\text{kg}\cdot\text{m}^2$ )	Static Torsional Stiffness (N·m/rad)	Mass (g)	Permissible Misalignment		
	D	L	L <sub>1</sub>	F									Angular (°)	Parallel (mm)	End-play (mm)
SJC-55-BL	55	78.3	30.3	14	M6	7	60	120	7,500	$1.7 \times 10^{-4}$	3,000	344	1	0.09	-0.5 ~ +1.4
SJC-55-DG	55	78.3	30.3	14	M6	7	60	120	7,500	$1.7 \times 10^{-4}$	4,500	344	1	0.08	-0.5 ~ +1.4
SJC-55-GR	55	78.3	30.3	14	M6	7	60	120	7,500	$1.7 \times 10^{-4}$	4,500	344	1	0.09	-0.5 ~ +1.4
SJC-55-RD	55	78.3	30.3	14	M6	7	75	150	7,500	$1.7 \times 10^{-4}$	6,000	344	1	0.06	-0.5 ~ +1.4
SJC-65-BL	65	90.3	35.3	17.2	M8	15	150	300	6,000	$3.9 \times 10^{-4}$	6,500	535	1	0.1	-0.6 ~ +1.5
SJC-65-DG	65	90.3	35.3	17.2	M8	15	150	300	6,000	$3.9 \times 10^{-4}$	8,500	535	1	0.09	-0.6 ~ +1.5
SJC-65-GR	65	90.3	35.3	17.2	M8	15	150	300	6,000	$3.9 \times 10^{-4}$	8,500	535	1	0.1	-0.6 ~ +1.5
SJC-65-RD	65	90.3	35.3	17.2	M8	15	180	360	6,000	$3.9 \times 10^{-4}$	10,000	535	1	0.08	-0.6 ~ +1.5
SJC-80-BL	80	114.2	45.2	21.7	M8	15	300	600	5,000	$1.1 \times 10^{-3}$	8,000	1,150	1	0.1	-0.6 ~ +1.5
SJC-80-DG	80	114.2	45.2	21.7	M8	15	300	600	5,000	$1.1 \times 10^{-3}$	12,000	1,150	1	0.09	-0.6 ~ +1.5
SJC-80-GR	80	114.2	45.2	21.7	M8	15	300	600	5,000	$1.1 \times 10^{-3}$	12,000	1,150	1	0.1	-0.6 ~ +1.5
SJC-80-RD	80	114.2	45.2	21.7	M8	15	380	760	5,000	$1.1 \times 10^{-3}$	14,000	1,150	1	0.08	-0.6 ~ +1.5
SJC-100-BL	104	140.2	56.2	27.3	M10	25	500	1,000	4,000	$4.8 \times 10^{-3}$	24,000	2,650	1	0.15	-0.6 ~ +2.0
SJC-100-DG	104	140.2	56.2	27.3	M10	25	500	1,000	4,000	$4.8 \times 10^{-3}$	24,000	2,650	1	0.12	-0.6 ~ +2.0
SJC-100-GR	104	140.2	56.2	27.3	M10	25	500	1,000	4,000	$4.8 \times 10^{-3}$	30,000	2,650	1	0.15	-0.6 ~ +2.0
SJC-100-RD	104	140.2	56.2	27.3	M10	25	600	1,200	4,000	$4.8 \times 10^{-3}$	40,000	2,650	1	0.1	-0.6 ~ +2.0

- The Moment of Inertia and Mass values are based on products with max. Inner diameter.
- Please modify rated/max. torque value with temperature correction factor when it's higher than 30°C.
- Max. torque/rated torque is the value regarding to a coupling's self-durability and is not related to slip-torque between the coupling bore and the shaft. (Set-screw type is usually less durable than other clamping method, thus please consider it has a complementary option e.g. keyway along with.)

### Standard Inner Diameter (ID)

Model	Standard Inner Diameter ( $d_1, d_2$ ) (mm)																		
	12	14	15	16	18	19	20	22	24	25	26	28	30	32	35	40	45	50	60
SJC-55	●	●	●	●	●	●	●	●	●	●	●	●							
SJC-65			●	●	●	●	●	●	●	●	●	●	●	●	●				
SJC-80			●	●	●	●	●	●	●	●	●	●	●	●	●	●	●		
SJC-100							●	●	●	●	●	●	●	●	●	●	●	●	●

- The recommended shaft tolerance is h7.
- Custom process (e.g. non-standard Inner diameter, special tolerance etc.) is also available upon a special request in prior to order placement.
- Keyway is available. (Optional)

# SJC SERIES

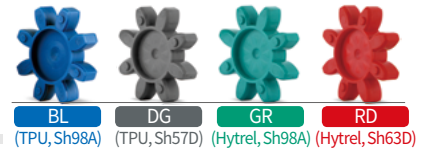

## Jaw Coupling

### Side-clamp

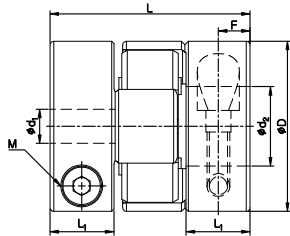

Size: 14C ~ A-30C

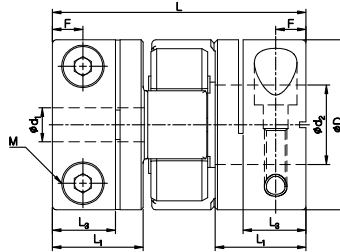

Size: B-30C

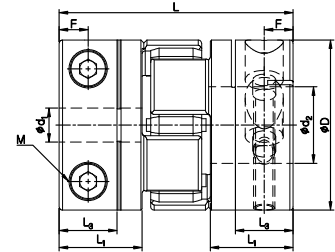

Size: 40C

### Dimensions / Performance

Model	Size (±0.3mm)					Screw Size	Fastening Torque (N·m)	Rated Torque (N·m)	Max. Torque (N·m)	Max. rpm (min <sup>-1</sup> )	Moment of Inertia (kg·m <sup>2</sup> )	Static Torsional Stiffness (N·m/rad)	Mass (g)	Permissible Misalignment			Side-clamp Hub Split (W)
	D	L	L <sub>1</sub>	L <sub>3</sub>	F									Angular (°)	Parallel (mm)	End-play (mm)	
SJC-14C-BL	14	22	7	-	3.5	M2	0.5	2	4	22,000	1.6×10 <sup>-7</sup>	22	6	1	0.05	-0.2 ~ +0.6	X
SJC-14C-GR	14	22	7	-	3.5	M2	0.5	2	4	22,000	1.6×10 <sup>-7</sup>	25	6	1	0.05	-0.2 ~ +0.6	X
SJC-14C-RD	14	22	7	-	3.5	M2	0.5	2.5	5	22,000	1.6×10 <sup>-7</sup>	34	6	1	0.03	-0.2 ~ +0.6	X
SJC-20C-BL	20	30	10	-	5	M2.6	1	4	8	15,000	1.1×10 <sup>-6</sup>	50	19	1	0.07	-0.3 ~ +0.8	X
SJC-20C-GR	20	30	10	-	5	M2.6	1	4	8	15,000	1.1×10 <sup>-6</sup>	60	19	1	0.07	-0.3 ~ +0.8	X
SJC-20C-RD	20	30	10	-	5	M2.6	1	6	12	15,000	1.1×10 <sup>-6</sup>	74	19	1	0.05	-0.3 ~ +0.8	X
SJC-25C-BL	25	31.3	10	-	5	M3	1.7	9	18	13,000	2.4×10 <sup>-6</sup>	220	25	1	0.07	-0.4 ~ +1.0	X
SJC-25C-GR	25	31.3	10	-	5	M3	1.7	9	18	13,000	2.4×10 <sup>-6</sup>	260	25	1	0.07	-0.4 ~ +1.0	X
SJC-25C-RD	25	31.3	10	-	5	M3	1.7	12	24	13,000	2.4×10 <sup>-6</sup>	300	25	1	0.05	-0.4 ~ +1.0	X
SJCA-30C-BL	30	35.3	11.3	-	5.6	M4	3.5	12	24	10,000	6.2×10 <sup>-6</sup>	170	50	1	0.08	-0.4 ~ +1.0	X
SJCA-30C-GR	30	35.3	11.3	-	5.6	M4	3.5	12	24	10,000	6.2×10 <sup>-6</sup>	200	50	1	0.08	-0.4 ~ +1.0	X
SJCA-30C-RD	30	35.3	11.3	-	5.6	M4	3.5	16	32	10,000	6.2×10 <sup>-6</sup>	220	50	1	0.06	-0.4 ~ +1.0	X
SJCB-30C-BL	30	44.7	16	11.1	5.4	M4	3.5	12	24	10,000	7.5×10 <sup>-6</sup>	170	55	1	0.08	-0.4 ~ +1.0	○
SJCB-30C-GR	30	44.7	16	11.1	5.4	M4	3.5	12	24	10,000	7.5×10 <sup>-6</sup>	200	55	1	0.08	-0.4 ~ +1.0	○
SJCB-30C-RD	30	44.7	16	11.1	5.4	M4	3.5	16	32	10,000	7.5×10 <sup>-6</sup>	220	55	1	0.06	-0.4 ~ +1.0	○
SJCA-40C-BL	40	55	19.5	13.6	6.8	M5	8	17	34	8,500	3.1×10 <sup>-5</sup>	1,500	135	1	0.06	-0.5 ~ +1.2	○
SJCA-40C-GR	40	55	19.5	13.6	6.8	M5	8	17	34	8,500	3.1×10 <sup>-5</sup>	1,600	135	1	0.06	-0.5 ~ +1.2	○
SJCA-40C-RD	40	55	19.5	13.6	6.8	M5	8	21	42	8,500	3.1×10 <sup>-5</sup>	1,750	135	1	0.04	-0.5 ~ +1.2	○
SJCB-40C-BL	40	66	25	16.5	8.4	M5	8	17	34	8,500	3.9×10 <sup>-5</sup>	1,500	160	1	0.06	-0.5 ~ +1.2	○
SJCB-40C-GR	40	66	25	16.5	8.4	M5	8	17	34	8,500	3.9×10 <sup>-5</sup>	1,600	160	1	0.06	-0.5 ~ +1.2	○
SJCB-40C-RD	40	66	25	16.5	8.4	M5	8	21	42	8,500	3.9×10 <sup>-5</sup>	1,750	160	1	0.04	-0.5 ~ +1.2	○

- The Moment of Inertia and Mass values are based on products with max. Inner diameter.
- Please modify rated/max. torque value with temperature correction factor when it's higher than 30°C.
- Max. torque/rated torque is the value regarding to a coupling's self-durability and is not related to slip-torque between the coupling bore and the shaft.

### Standard Inner Diameter (ID)

Model	Standard Inner Diameter (d <sub>1</sub> , d <sub>2</sub> ) (mm)																
	3	4	4.5	5	6	6.35	7	8	9	9.525	10	11	12	14	15	16	18
SJC□-14C	●	●	●	●													
SJC□-20C		●	●	●	●	●	●	●									
SJC□-25C				●	●	●	●	●	●	●	●						
SJC□-30C					●	●	●	●	●	●	●	●	●	●			
SJC□-40C								●	●	●	●	●	●	●	●	●	●

- The recommended shaft tolerance is h7.
- Custom process (e.g. non-standard Inner diameter, special tolerance etc.) is also available upon a special request in prior to order placement.
- Keyway is available. (Optional)

# SJC SERIES

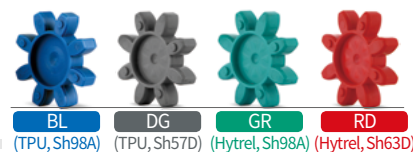

## Jaw Coupling

### Side-clamp

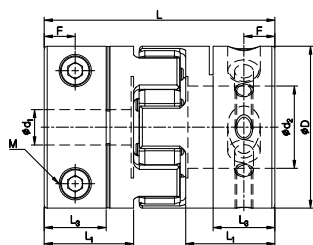

Size: 48C ~ 80C

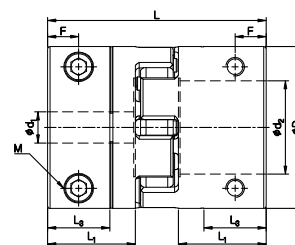

Size: 90C ~ 100C

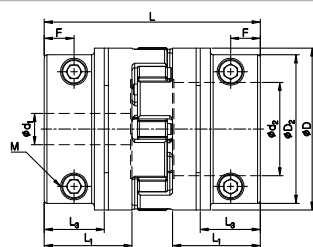

Size: 120C ~ 135C

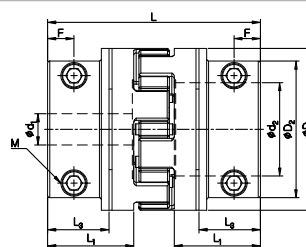

Size: 160C

### Dimensions / Performance

Model	Size (±0.3mm)						Screw		Rated Torque (N·m)	Max. Torque (N·m)	Max. rpm (min <sup>-1</sup> )	Moment of Inertia (kg·m <sup>2</sup> )	Static Torsional Stiffness (N·m/rad)	Mass (g)	Permissible Misalignment			Side-clamp Hub Split (W)
	D	L	D <sub>2</sub>	L <sub>1</sub>	L <sub>3</sub>	F	Size	Fastening Torque (N·m)							Angular (°)	Parallel (mm)	End-play (mm)	
SJC-48C-BL	48	66.8	-	25.3	17.4	9	M6	13	35	70	7,000	8.2×10 <sup>-5</sup>	1,800	224	1	0.08	-0.6 ~ +1.3	○
SJC-48C-GR	48	66.8	-	25.3	17.4	9	M6	13	35	70	7,000	8.2×10 <sup>-5</sup>	2,800	224	1	0.08	-0.6 ~ +1.3	○
SJC-48C-RD	48	66.8	-	25.3	17.4	9	M6	13	40	80	7,000	8.2×10 <sup>-5</sup>	3,600	224	1	0.05	-0.6 ~ +1.3	○
SJC-55C-BL	55	78.3	-	30.3	21	10.5	M6	13	60	120	6,500	1.6×10 <sup>-4</sup>	3,000	330	1	0.09	-0.5 ~ +1.4	○
SJC-55C-DG	55	78.3	-	30.3	21	10.5	M6	13	60	120	6,500	1.6×10 <sup>-4</sup>	4,500	330	1	0.08	-0.5 ~ +1.4	○
SJC-55C-GR	55	78.3	-	30.3	21	10.5	M6	13	60	120	6,500	1.6×10 <sup>-4</sup>	4,500	330	1	0.09	-0.5 ~ +1.4	○
SJC-55C-RD	55	78.3	-	30.3	21	10.5	M6	13	75	150	6,500	1.6×10 <sup>-4</sup>	6,000	330	1	0.06	-0.5 ~ +1.4	○
SJC-65C-BL	65	90.3	-	35.3	25.6	12.5	M8	30	150	300	5,500	3.8×10 <sup>-4</sup>	6,500	560	1	0.1	-0.6 ~ +1.5	○
SJC-65C-DG	65	90.3	-	35.3	25.6	12.5	M8	30	150	300	5,500	3.8×10 <sup>-4</sup>	8,500	560	1	0.09	-0.6 ~ +1.5	○
SJC-65C-GR	65	90.3	-	35.3	25.6	12.5	M8	30	150	300	5,500	3.8×10 <sup>-4</sup>	8,500	560	1	0.1	-0.6 ~ +1.5	○
SJC-65C-RD	65	90.3	-	35.3	25.6	12.5	M8	30	180	360	5,500	3.8×10 <sup>-4</sup>	10,000	560	1	0.08	-0.6 ~ +1.5	○
SJC-80C-BL	80	114.2	-	45.2	30.2	14.7	M10	50	300	600	4,500	1.0×10 <sup>-3</sup>	8,000	1,050	1	0.1	-0.6 ~ +1.5	○
SJC-80C-DG	80	114.2	-	45.2	30.2	14.7	M10	50	300	600	4,500	1.0×10 <sup>-3</sup>	12,000	1,050	1	0.09	-0.6 ~ +1.5	○
SJC-80C-GR	80	114.2	-	45.2	30.2	14.7	M10	50	300	600	4,500	1.0×10 <sup>-3</sup>	12,000	1,050	1	0.1	-0.6 ~ +1.5	○
SJC-80C-RD	80	114.2	-	45.2	30.2	14.7	M10	50	380	760	4,500	1.0×10 <sup>-3</sup>	14,000	1,050	1	0.08	-0.6 ~ +1.5	○
SJC-90C-BL	95	126	-	50	35	18	M10	50	450	900	3,500	2.3×10 <sup>-3</sup>	12,000	1,640	1	0.15	-0.6 ~ +2.0	○
SJC-90C-DG	95	126	-	50	35	18	M10	50	450	900	3,500	2.3×10 <sup>-3</sup>	14,000	1,640	1	0.12	-0.6 ~ +2.0	○
SJC-90C-GR	95	126	-	50	35	18	M10	50	450	900	3,500	2.3×10 <sup>-3</sup>	14,000	1,640	1	0.15	-0.6 ~ +2.0	○
SJC-90C-RD	95	126	-	50	35	18	M10	50	500	1,000	3,500	2.3×10 <sup>-3</sup>	16,000	1,640	1	0.1	-0.6 ~ +2.0	○
SJC-100C-BL	104	140.2	-	56.2	39.9	19.9	M12	90	500	1,000	3,500	4.6×10 <sup>-3</sup>	24,000	2,550	1	0.15	-0.6 ~ +2.0	○
SJC-100C-DG	104	140.2	-	56.2	39.9	19.9	M12	90	500	1,000	3,500	4.6×10 <sup>-3</sup>	24,000	2,550	1	0.12	-0.6 ~ +2.0	○
SJC-100C-GR	104	140.2	-	56.2	39.9	19.9	M12	90	500	1,000	3,500	4.6×10 <sup>-3</sup>	30,000	2,550	1	0.15	-0.6 ~ +2.0	○
SJC-100C-RD	104	140.2	-	56.2	39.9	19.9	M12	90	600	1,200	3,500	4.6×10 <sup>-3</sup>	40,000	2,550	1	0.1	-0.6 ~ +2.0	○
SJC-120C-GR	120	160	110	65	44.5	22	M12	115	620	1,240	3,150	2.4×10 <sup>-2</sup>	50,000	7,390	0.9	0.16	-1.0 ~ +2.2	○
SJC-120C-RD	120	160	110	65	44.5	22	M12	115	740	1,480	3,150	2.4×10 <sup>-2</sup>	90,000	7,390	0.8	0.11	-1.0 ~ +2.2	○
SJC-135C-GR	135	185	115	75	54.5	27	M12	115	850	1,700	2,800	4.0×10 <sup>-2</sup>	60,000	9,900	0.9	0.17	-1.0 ~ +2.6	○
SJC-135C-RD	135	185	115	75	54.5	27	M12	115	1,050	2,100	2,800	4.0×10 <sup>-2</sup>	100,000	9,900	0.8	0.12	-1.0 ~ +2.6	○
SJC-160C-GR	160	210	135	85	60.5	26	M16	280	1,700	3,400	2,350	8.6×10 <sup>-2</sup>	90,000	16,300	0.9	0.2	-1.5 ~ +3.0	○
SJC-160C-RD	160	210	135	85	60.5	26	M16	280	2,100	4,200	2,350	8.6×10 <sup>-2</sup>	150,000	16,300	0.8	0.14	-1.5 ~ +3.0	○

- The Moment of Inertia and Mass values are based on products with max. Inner diameter.
- Please modify rated/max. torque value with temperature correction factor when it's higher than 30°C.
- Max. torque/rated torque is the value regarding to a coupling's self-durability and is not related to slip-torque between the coupling bore and the shaft.

# SJC SERIES

## Jaw Coupling

### Standard Inner Diameter (ID)

Model	Standard Inner Diameter (d <sub>1</sub> , d <sub>2</sub> ) (mm)																							
	10	12	14	15	16	18	19	20	22	24	25	26	28	30	32	35	40	45	50	60	65	70	75	80
SJC-48C	●	●	●	●	●	●	●	●	●	●														
SJC-55C		●	●	●	●	●	●	●	●	●	●	●												
SJC-65C				●	●	●	●	●	●	●	●	●	●	●	●									
SJC-80C				●	●	●	●	●	●	●	●	●	●	●	●	●	●	●						
SJC-100C							●	●	●	●	●	●	●	●	●	●	●	●	●	●				
SJC-120C															●	●	●	●	●	●	●	●		
SJC-135C																●	●	●	●	●	●	●	●	
SJC-160C																	●	●	●	●	●	●	●	●

- The recommended shaft tolerance is h7.
- Custom process (e.g. non-standard Inner diameter, special tolerance etc.) is also available upon a special request in prior to order placement.
- Keyway is available. (Optional)
- Side-clamp Hub Split is available (Optional)

### Slip Torque

- The below table shows the actual permissible torque values when the slip torque value is lower than the coupling's max. torque value.
- If the slip torque value is lower than the coupling's max. torque value, please check and compare between the slip torque in the below table and the operating torque value of the connected motor. It is safer to size up the coupling or use a key/keyway when the slip torque value is lower than the motor's operating torque.
- The below slip torque values may be subject to change according to different testing conditions. (e.g. shaft tolerance, surface roughness, surface treatment or acceleration/deceleration of driving shafts). On the other hand, the values could be affected when a different kind of fastening screw is used (body material or surface treatment). Therefore, we recommend you test under the same conditions before mounting.

Model	Max. Torque (N.m) RD Sleeve	Slip Torque (N.m) by Inner Diameter (d <sub>1</sub> , d <sub>2</sub> )															
		3	4	4.5	5	6	6.35	7	8	9.525	10	11	12	14	15	16	18
SJC□-14C	4.8	0.6	0.8	0.9	1	1.2											
SJC□-20C	12		1	1.5	2.5	3	3	3.5	5								
SJC□-25C	24				3.5	4	4.5	4.5	5	8	9						
SJC□-30C	32					6	6.5	7	8	9.5	11	12	14	16			
SJC□-40C	42								22	25	28	30	32				

Model	Max. Torque (N.m) RD Sleeve	Slip Torque (N.m) by Inner Diameter (d <sub>1</sub> , d <sub>2</sub> )																					
		10	12	14	15	16	18	19	20	22	24	25	26	28	30	32	35	40	45	50	60		
SJC-48C	80	40	48	65	70	75																	
SJC-55C	150		50	60	65	70	75	80	90	100	110	120	130	140									
SJC-65C	360				80	85	90	100	120	150	160	170	170	180	190	200	250						
SJC-80C	760				90	95	100	110	121	132	141	150	162	175	180	187	193	200	250				
SJC-90C	1000						140	176	208	230	240	245	250	250	265	300	320	360	370	460			
SJC-100C	1200								300	330	350	390	390	400	410	420	430	450	470	490	550		

### Side-clamp Hub Split(W) Option is available

- From certain outer diameter (OD) sizes, we can provide Side-clamp Hub Split products.
- Please refer to "HOW TO ORDER" page for more details.

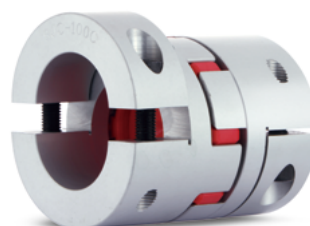

# SJC SERIES (SJCM)

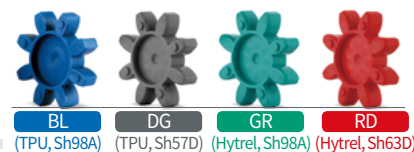

## Jaw Coupling

### Side-clamp (Spacer-saving)

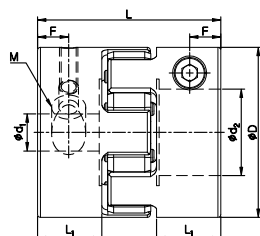

Size: 55C ~ 80C

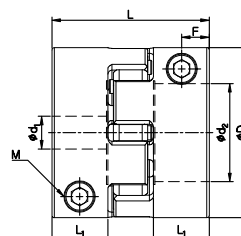

Size: 100C

### Dimensions / Performance

Model	Size (±0.3mm)				Screw		Rated Torque (N·m)	Max. Torque (N·m)	Max. rpm (min <sup>-1</sup> )	Moment of Inertia (kg·m <sup>2</sup> )	Static Torsional Stiffness (N·m/rad)	Mass (g)	Permissible Misalignment		
	D	L	L <sub>1</sub>	F	Size	Fastening Torque (N·m)							Angular (°)	Parallel (mm)	End-play (mm)
SJCM-55C-BL	55	59.3	20.8	10.1	M6	13	60	120	4,000	1.3×10 <sup>-4</sup>	3,000	280	1	0.09	-0.5 ~ +1.4
SJCM-55C-DG	55	59.3	20.8	10.1	M6	13	60	120	4,000	1.3×10 <sup>-4</sup>	4,500	280	1	0.08	-0.5 ~ +1.4
SJCM-55C-GR	55	59.3	20.8	10.1	M6	13	60	120	4,000	1.3×10 <sup>-4</sup>	4,500	280	1	0.09	-0.5 ~ +1.4
SJCM-55C-RD	55	59.3	20.8	10.1	M6	13	75	150	4,000	1.3×10 <sup>-4</sup>	6,000	280	1	0.06	-0.5 ~ +1.4
SJCM-65C-BL	65	63.3	21.8	10.5	M8	30	150	300	3,500	2.6×10 <sup>-4</sup>	6,500	400	1	0.1	-0.6 ~ +1.5
SJCM-65C-DG	65	63.3	21.8	10.5	M8	30	150	300	3,500	2.6×10 <sup>-4</sup>	8,500	400	1	0.09	-0.6 ~ +1.5
SJCM-65C-GR	65	63.3	21.8	10.5	M8	30	150	300	3,500	2.6×10 <sup>-4</sup>	8,500	400	1	0.1	-0.6 ~ +1.5
SJCM-65C-RD	65	63.3	21.8	10.5	M8	30	180	360	3,500	2.6×10 <sup>-4</sup>	10,000	400	1	0.08	-0.6 ~ +1.5
SJCM-80C-BL	80	87.2	31.7	15.5	M10	50	300	600	3,000	8.7×10 <sup>-4</sup>	8,000	860	1	0.1	-0.6 ~ +1.5
SJCM-80C-DG	80	87.2	31.7	15.5	M10	50	300	600	3,000	8.7×10 <sup>-4</sup>	12,000	860	1	0.09	-0.6 ~ +1.5
SJCM-80C-GR	80	87.2	31.7	15.5	M10	50	300	600	3,000	8.7×10 <sup>-4</sup>	12,000	860	1	0.1	-0.6 ~ +1.5
SJCM-80C-RD	80	87.2	31.7	15.5	M10	50	380	760	3,000	8.7×10 <sup>-4</sup>	14,000	860	1	0.08	-0.6 ~ +1.5
SJCM-100C-BL	104	96.2	34.2	16.9	M12	90	500	1,000	3,000	3.1×10 <sup>-3</sup>	24,000	1,700	1	0.15	-0.6 ~ +2.0
SJCM-100C-DG	104	96.2	34.2	16.9	M12	90	500	1,000	3,000	3.1×10 <sup>-3</sup>	24,000	1,700	1	0.12	-0.6 ~ +2.0
SJCM-100C-GR	104	96.2	34.2	16.9	M12	90	500	1,000	3,000	3.1×10 <sup>-3</sup>	30,000	1,700	1	0.15	-0.6 ~ +2.0
SJCM-100C-RD	104	96.2	34.2	16.9	M12	90	600	1,200	3,000	3.1×10 <sup>-3</sup>	40,000	1,700	1	0.1	-0.6 ~ +2.0

### Standard Inner Diameter (ID)

Model	Standard Inner Diameter (d <sub>1</sub> , d <sub>2</sub> ) (mm)																		
	12	14	15	16	18	19	20	22	24	25	26	28	30	32	35	40	45	50	60
SJCM-55C	●	●	●	●	●	●	●	●	●	●	●	●							
SJCM-65C			●	●	●	●	●	●	●	●	●	●	●	●	●				
SJCM-80C			●	●	●	●	●	●	●	●	●	●	●	●	●	●	●		
SJCM-100C						●	●	●	●	●	●	●	●	●	●	●	●	●	●

- The recommended shaft tolerance is h7.
- Keyway is available. (Optional)
- Custom process (e.g. non-standard Inner diameter, special tolerance etc.) is also available upon a special request in prior to order placement.
- Side-clamp Hub Split is **NOT** available

### Slip Torque

- The below table shows the actual permissible torque values when the slip torque value is lower than the coupling's max. torque value.
- If the slip torque value is lower than the coupling's max. torque value, please check and compare between the slip torque in the below table and the operating torque value of the connected motor. It is safer to size up the coupling or use a key/keyway when the slip torque value is lower than the motor's operating torque.
- The below slip torque values may be subject to change according to different testing conditions. (e.g. shaft tolerance, surface roughness, surface treatment or acceleration/deceleration of driving shafts). On the other hand, the values could be affected when a different kind of fastening screw is used (body material or surface treatment). Therefore, we recommend you test under the same conditions before mounting.

Model	Max. Torque (N·m) RD Sleeve	Slip Torque (N·m) by Inner Diameter (d <sub>1</sub> , d <sub>2</sub> )																		
		12	14	15	16	18	19	20	22	24	25	26	28	30	32	35	40	45	50	60
SJCM-55C	150	40	55	65	75	95	100	110	120	120	120	120								
SJCM-65C	360			55	60	70	75	80	85	94	98	103	110	118	125	130				
SJCM-80C	760			90	100	110	118	125	130	150	155	160	175	185	200	220	250	280		
SJCM-100C	1200							200	230	260	290	320	360	390	410	435	450	460	480	550

# SJC SERIES

## Jaw Coupling

### Taper-ring

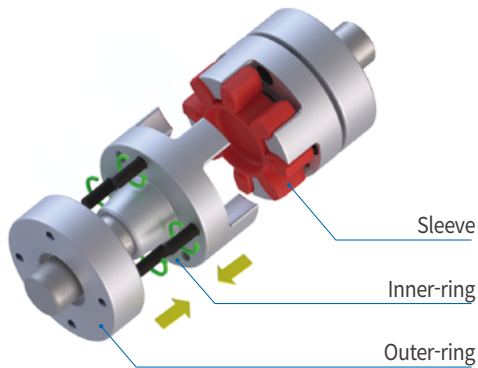

#### Principles

- When inner screws are fastened, the inner ring and outer ring move closer each other by the thrust of screws and the taper ring structure.
- The inner ring shrinks evenly and gives contact pressure on shafts and then the shaft and the coupling are tightly interlocked.
- Perfect symmetry for the rotating shafts.

#### Feature 1 Perfect Rotation Balancing

Example) Comparison between 2 products with the identical OD (55mm) and different clamping methods shows the results as below.

Model name	Clamping Methods	Unbalance (g·mm)
SJC-55T	Taper-ring	0.7
SJC-55C	Side-clamp	21.6

- Unbalance is the main reason that causes noise and vibration on high speed rotating applications
- The Taper type product has the structure of complete symmetry which leads to nearly zero-unbalance

※ The above values may be subject to change based on test conditions (e.g. shaft material or tolerance)

#### Feature 2 Stronger Clamping Force on Shafts

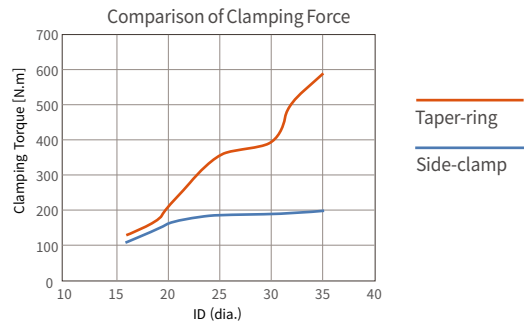

- Excellent Clamping force comparing to Set-screw or Side-clamp type
- Enough clamping force is granted without keyway

### HOW TO INSTALL

- Step 1. Firstly remove dust or oil substances from the surface where outer and inner ring hubs face each other as well as the surface of the inserting shaft.
- Step 2. Spread oil thinly on the surface where outer and inner ring hubs face each other as well as the surface of the inserting shaft. (Any oil type which includes molybdenum-sulfur compounds or silicone is prohibited)
- Step 3. Insert the shaft up to L<sub>1</sub> of the inner ring hub.
- Step 4. Fasten the screws with 1/2 of fastening torque one time each in sequential order as shown on the below Fig.(1)

Fig.(1)

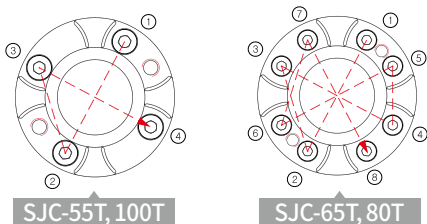

- Step 5. Fasten the screws with full of fastening torque one time each in sequential order as shown on the below Fig.(1)
- Step 6. Fasten the screws with full of fastening torque in sequential order as shown on the below Fig.(2). Repeat Step 6 until all screws are fastened appropriately.

※ Please refer to "Dimensions / Performance" tables for fastening torques.

Fig.(2)

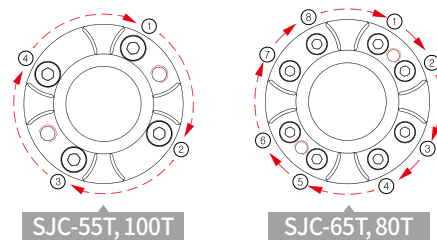

# SJC SERIES

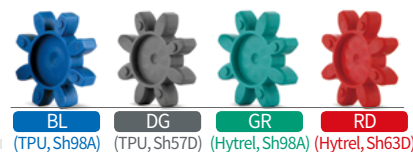

## Jaw Coupling

### Taper-ring

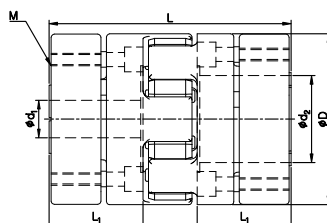

### Dimensions / Performance

Model	Size (±0.3mm)			Screw		Rated Torque (N·m)	Max. Torque (N·m)	Max. rpm (min <sup>-1</sup> )	Moment of Inertia (kg·m <sup>2</sup> )	Static Torsional Stiffness (N·m/rad)	Mass (g)	Permissible Misalignment		
	D	L	L <sub>1</sub>	Size	Fastening Torque (N·m)							Angular (°)	Parallel (mm)	End-play (mm)
SJC-55T-BL	55	78.3	30.3	M5	8	60	120	14,000	1.59×10 <sup>-4</sup>	3,000	345	1	0.09	-0.5 ~ +1.4
SJC-55T-DG	55	78.3	30.3	M5	8	60	120	14,000	1.59×10 <sup>-4</sup>	4,500	345	1	0.08	-0.5 ~ +1.4
SJC-55T-GR	55	78.3	30.3	M5	8	60	120	14,000	1.59×10 <sup>-4</sup>	4,500	345	1	0.09	-0.5 ~ +1.4
SJC-55T-RD	55	78.3	30.3	M5	8	75	150	14,000	1.59×10 <sup>-4</sup>	6,000	345	1	0.06	-0.5 ~ +1.4
SJC-65T-BL	65	90.3	35.3	M5	8	150	300	12,000	3.75×10 <sup>-4</sup>	6,500	536	1	0.1	-0.6 ~ +1.5
SJC-65T-DG	65	90.3	35.3	M5	8	150	300	12,000	3.75×10 <sup>-4</sup>	8,500	536	1	0.09	-0.6 ~ +1.5
SJC-65T-GR	65	90.3	35.3	M5	8	150	300	12,000	3.75×10 <sup>-4</sup>	8,500	536	1	0.1	-0.6 ~ +1.5
SJC-65T-RD	65	90.3	35.3	M5	8	180	360	12,000	3.75×10 <sup>-4</sup>	10,000	536	1	0.08	-0.6 ~ +1.5
SJC-80T-BL	80	114.2	45.2	M6	13	300	600	9,500	1.09×10 <sup>-3</sup>	8,000	1,043	1	0.1	-0.6 ~ +1.5
SJC-80T-DG	80	114.2	45.2	M6	13	300	600	9,500	1.09×10 <sup>-3</sup>	12,000	1,043	1	0.09	-0.6 ~ +1.5
SJC-80T-GR	80	114.2	45.2	M6	13	300	600	9,500	1.09×10 <sup>-3</sup>	12,000	1,043	1	0.1	-0.6 ~ +1.5
SJC-80T-RD	80	114.2	45.2	M6	13	380	760	9,500	1.09×10 <sup>-3</sup>	14,000	1,043	1	0.08	-0.6 ~ +1.5
SJC-100T-BL	104	140.2	56	M10	50	500	1,000	7,500	3.70×10 <sup>-3</sup>	24,000	2,126	1	0.15	-0.6 ~ +2.0
SJC-100T-DG	104	140.2	56	M10	50	500	1,000	7,500	3.70×10 <sup>-3</sup>	24,000	2,126	1	0.12	-0.6 ~ +2.0
SJC-100T-GR	104	140.2	56	M10	50	500	1,000	7,500	3.70×10 <sup>-3</sup>	30,000	2,126	1	0.15	-0.6 ~ +2.0
SJC-100T-RD	104	140.2	56	M10	50	600	1,200	7,500	3.70×10 <sup>-3</sup>	40,000	2,126	1	0.1	-0.6 ~ +2.0

- The Moment of Inertia and Mass values are based on products with max. Inner diameter.
- Please modify rated/max. torque value with temperature correction factor when it's higher than 30°C.
- Max. torque/rated torque is the value regarding to a coupling's self-durability and is not related to slip-torque between the coupling bore and the shaft.

### Standard Inner Diameter (ID)

Model	Standard Inner Diameter (d <sub>1</sub> , d <sub>2</sub> ) (mm)																		
	12	14	15	16	18	19	20	22	24	25	26	28	30	32	35	40	45	50	55
SJC-55T	●	●	●	●	●	●	●	●	●	●	●	●							
SJC-65T			●	●	●	●	●	●	●	●	●	●	●	●	●				
SJC-80T			●	●	●	●	●	●	●	●	●	●	●	●	●	●	●		
SJC-100T							●	●	●	●	●	●	●	●	●	●	●	●	●

- The recommended shaft tolerance is h7.
- Custom process (e.g. non-standard Inner diameter, special tolerance etc.) is also available upon a special request in prior to order placement.
- Keyway is **NOT** available.

### Slip Torque

- The below table shows the actual permissible torque values when the slip torque value is lower than the coupling's max. torque value.
- If the slip torque value is lower than the coupling's max. torque value, please check and compare between the slip torque in the below table and the operating torque value of the connected motor. It is safer to size up the coupling or use a key/keyway when the slip torque value is lower than the motor's operating torque.
- The below slip torque values may be subject to change according to different testing conditions. (e.g. shaft tolerance, surface roughness, surface treatment or acceleration/deceleration of driving shafts). On the other hand, the values could be affected when a different kind of fastening screw is used (body material or surface treatment). Therefore, we recommend you test under the same conditions before mounting.

Model	Max. Torque (N·m) RD Sleeve	Slip Torque (N·m) by Inner Diameter (d <sub>1</sub> , d <sub>2</sub> )																		
		12	14	15	16	18	19	20	22	24	25	26	28	30	32	35	40	45	50	55
SJC-55T	150	65	65	80	80	100	105	125	125	125	130									
SJC-65T	360			100	110	120	130	150	200	240	250	260	270	280	290	300				
SJC-80T	760			150	160	180	190	210	330	350	380	400	450	540	540	580	600	620		
SJC-100T	1200							420	450	480	500	530	590	650	700	700	700	700	700	

# SJC SERIES

## Jaw Coupling

### Shaft-insertion

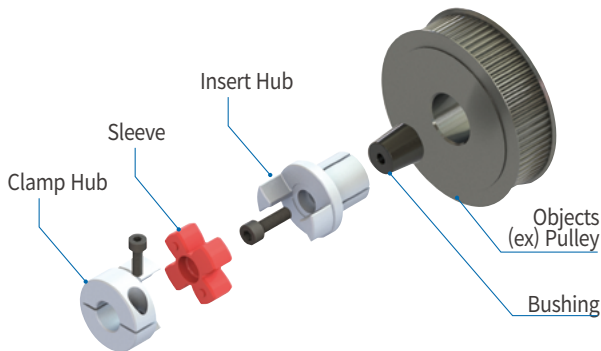

#### Features of SJC-I Series

- Easy attachment to various hub types e.g. Pulleys, Gears, Sprockets, or Hollow shafts
- Space-saving design
- Simple clamping methods by tightening a single bolt
- Self-centering function by the taper structure
- Various types of coupling hubs (e.g. Side-clamp, Set-screw) can be combined

#### Principles

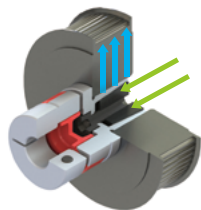

- Bushing and Insert hub are tightly coupled by the thrust of fastening screws.
- And then the insert part gets spread outward due to the taper structure and clamped into the inner diameter on the other side.

#### Dimensions

Model	Coupling hub OD	Shaft-insertion hub OD
SJC-25I□	25mm	10mm
SJC□-30I□	30mm	12mm
SJC□-40I□	40mm	20mm
SJC-55I□	55mm	25mm
SJC-65I□	65mm	35mm

※ OD: Outer Diameter  
 ※ Please contact Sung-il Customer Service team for non-standard Inserted hub OD products.

#### How to Disassemble

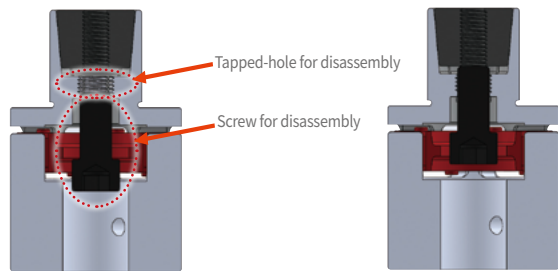

① Please refer to the below table.

Model	Fastening screw	Screw for disassembly
SJC-25I	M3	M4
SJC-30I	M4	M5
SJC-40I	M6	M8
SJC-55I	M8	M10
SJC-65I	M10	M12

② After removing fastening screws, insert a screw for disassembly and fasten it into the tapped-hole for disassembly. And then, bushing comes out being disassembled by thrust of the screw.

#### HOW TO ORDER

**Shaft-insertion x Side-clamp**

SJC - 65 - IC - RD - TH - 35 I x 25 C W K8

Model - OD(D) size - Clamping Methods - Sleeve Type - Center-Through (TH) - OD(D2) size - Shaft-insertion - ID(D1) size - Side-clamp - Split - Keyway (K)

---

**Shaft-insertion x Set-screw**

SJC - 65 - IS - RD - TH - 35 I x 25 S K8

Model - OD(D) size - Clamping Methods - Sleeve Type - Center-Through (TH) - OD(D2) size - Shaft-insertion - ID(D1) size - Set-screw - Keyway (K)

---

**Shaft-insertion x Taper-ring**

SJC - 65 - IT - RD - TH - 35 I x 25 T

Model - OD(D) size - Clamping Methods - Sleeve Type - Center-Through (TH) - OD(D2) size - Shaft-insertion - ID(D1) size - Taper-ring

※ The standard spacer for the SJC-I series is a center-through (TH) type.

# SJC SERIES

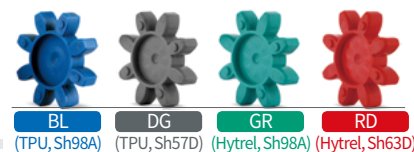

## Jaw Coupling

### Shaft-insertion x Side-clamp

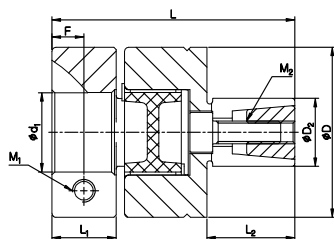

Size: 25IC ~ A-30IC

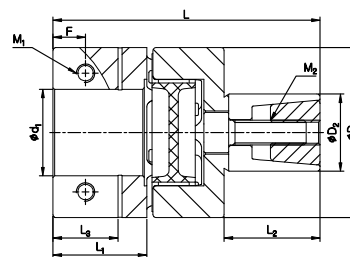

Size: B-30IC ~ 65IC

### Dimensions / Performance

Model	Size ( $\pm 0.3\text{mm}$ )							Screw		Screw (Shaft-insertion)		Slip Torque (N-m)	Max. rpm ( $\text{min}^{-1}$ )	Moment of Inertia ( $\text{kg}\cdot\text{m}^2$ )	Static Torsional Stiffness (N-m/rad)	Mass (g)	Permissible Misalignment			Side-clamp Hub Split (W)
	D	L	L <sub>1</sub>	L <sub>3</sub>	F	L <sub>2</sub>	D <sub>2</sub>	Size (M <sub>1</sub> )	Fastening Torque (N-m)	Size (M <sub>2</sub> )	Fastening Torque (N-m)						Angular (°)	Parallel (mm)	End-play (mm)	
SJC-25IC-BL	25	41.2	10	-	5	15.5	10	M3	1.7	M3	1.2	7	13,000	$4.7 \times 10^6$	220	30	1	0.07	-0.4 ~ +1.0	X
SJC-25IC-GR	25	41.2	10	-	5	15.5	10	M3	1.7	M3	1.2	7	13,000	$4.7 \times 10^6$	260	30	1	0.07	-0.4 ~ +1.0	X
SJC-25IC-RD	25	41.2	10	-	5	15.5	10	M3	1.7	M3	1.2	7	13,000	$4.7 \times 10^6$	300	30	1	0.05	-0.4 ~ +1.0	X
SJCA-30IC-BL	30	42.8	11.3	-	5.6	15.5	12	M4	3.5	M4	2.5	7.5	10,000	$9.3 \times 10^6$	170	46	1	0.08	-0.4 ~ +1.0	X
SJCA-30IC-GR	30	42.8	11.3	-	5.6	15.5	12	M4	3.5	M4	2.5	7.5	10,000	$9.3 \times 10^6$	200	46	1	0.08	-0.4 ~ +1.0	X
SJCA-30IC-RD	30	42.8	11.3	-	5.6	15.5	12	M4	3.5	M4	2.5	7.5	10,000	$9.3 \times 10^6$	220	46	1	0.06	-0.4 ~ +1.0	X
SJCB-30IC-BL	30	47.5	16	11.1	5.4	15.5	12	M4	3.5	M4	2.5	7.5	10,000	$1.2 \times 10^5$	170	52	1	0.08	-0.4 ~ +1.0	○
SJCB-30IC-GR	30	47.5	16	11.1	5.4	15.5	12	M4	3.5	M4	2.5	7.5	10,000	$1.2 \times 10^5$	200	52	1	0.08	-0.4 ~ +1.0	○
SJCB-30IC-RD	30	47.5	16	11.1	5.4	15.5	12	M4	3.5	M4	2.5	7.5	10,000	$1.2 \times 10^5$	220	52	1	0.06	-0.4 ~ +1.0	○
SJCA-40IC-BL	40	63.5	19.5	13.6	6.8	21	20	M5	8	M6	10	35	8,500	$5.6 \times 10^5$	1,500	136	1	0.06	-0.5 ~ +1.2	○
SJCA-40IC-GR	40	63.5	19.5	13.6	6.8	21	20	M5	8	M6	10	35	8,500	$5.6 \times 10^5$	1,600	136	1	0.06	-0.5 ~ +1.2	○
SJCA-40IC-RD	40	63.5	19.5	13.6	6.8	21	20	M5	8	M6	10	35	8,500	$5.6 \times 10^5$	1,750	136	1	0.04	-0.5 ~ +1.2	○
SJCB-40IC-BL	40	69	25	16.5	8.4	21	20	M5	8	M6	10	35	8,500	$7.4 \times 10^5$	1,500	151	1	0.06	-0.5 ~ +1.2	○
SJCB-40IC-GR	40	69	25	16.5	8.4	21	20	M5	8	M6	10	35	8,500	$7.4 \times 10^5$	1,600	151	1	0.06	-0.5 ~ +1.2	○
SJCB-40IC-RD	40	69	25	16.5	8.4	21	20	M5	8	M6	10	35	8,500	$7.4 \times 10^5$	1,750	151	1	0.04	-0.5 ~ +1.2	○
SJC-55IC-BL	55	86.3	30.3	21	10.5	31	25	M6	13	M8	20	80	6,500	$1.2 \times 10^4$	3,000	310	1	0.09	-0.5 ~ +1.4	○
SJC-55IC-DG	55	86.3	30.3	21	10.5	31	25	M6	13	M8	20	80	6,500	$1.2 \times 10^4$	4,500	310	1	0.08	-0.5 ~ +1.4	○
SJC-55IC-GR	55	86.3	30.3	21	10.5	31	25	M6	13	M8	20	80	6,500	$1.2 \times 10^4$	4,500	310	1	0.09	-0.5 ~ +1.4	○
SJC-55IC-RD	55	86.3	30.3	21	10.5	31	25	M6	13	M8	20	80	6,500	$1.2 \times 10^4$	6,000	310	1	0.06	-0.5 ~ +1.4	○
SJC-65IC-BL	65	99.3	35.3	25.6	12.5	37	35	M8	30	M10	40	180	5,500	$1.7 \times 10^4$	6,500	400	1	0.1	-0.6 ~ +1.5	○
SJC-65IC-DG	65	99.3	35.3	25.6	12.5	37	35	M8	30	M10	40	180	5,500	$1.7 \times 10^4$	8,500	400	1	0.09	-0.6 ~ +1.5	○
SJC-65IC-GR	65	99.3	35.3	25.6	12.5	37	35	M8	30	M10	40	180	5,500	$1.7 \times 10^4$	8,500	400	1	0.1	-0.6 ~ +1.5	○
SJC-65IC-RD	65	99.3	35.3	25.6	12.5	37	35	M8	30	M10	40	180	5,500	$1.7 \times 10^4$	10,000	400	1	0.08	-0.6 ~ +1.5	○

- The Moment of Inertia and Mass values are based on products with max. Inner diameter.
- Please modify rated/max. torque value with temperature correction factor when it's higher than 30°C.
- It's not allowed to have other complementary options to enhance clamping force such as keyway etc. on the shaft-insertion hub.
- Please contact Sung-il Customer Service team for non-standard Inserted hub OD(D<sub>2</sub>) products.
- Please refer to previous pages for the standard ID range of Side-clamp hubs.
- It's also possible to assemble with space-saving side-clamp, set-screw and taper-ring hubs.

# SJC SERIES (SJCP-T)

Jaw Coupling (For High-Precision, High-Speed Spindles)

## Taper-ring (For High-Precision, High-Speed Spindles)

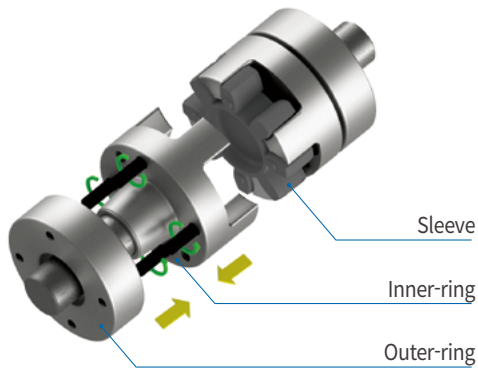

### Structure and Features

- Optimized for spindle drive systems requiring high precision and high speed
- Excellent centering accuracy and precise concentricity maintained through the combination of precision-machined hub and sleeve
- The tapered hub design, combined with inner and outer rings, provides simple yet strong fastening through bolt tightening

### Feature 1 Optimized for High-Precision / High-Speed Rotation

- Ensures highly accurate shaft fastening by applying IT6 tolerance to the bore
- Minimizes rotational vibration through strict control of inner and outer diameter run-out
- Enhances balance performance through structural symmetry and high precision

### Feature 2 Reliability / Assembly Efficiency

- Designed with consideration of appropriate axial assembly force, enabling easy installation and maintenance
- Improves backlash control and drive accuracy through optimized preload
- Ensures high reliability with excellent heat resistance, fatigue strength, and impact resistance

### Feature 3 Various Sleeve Options

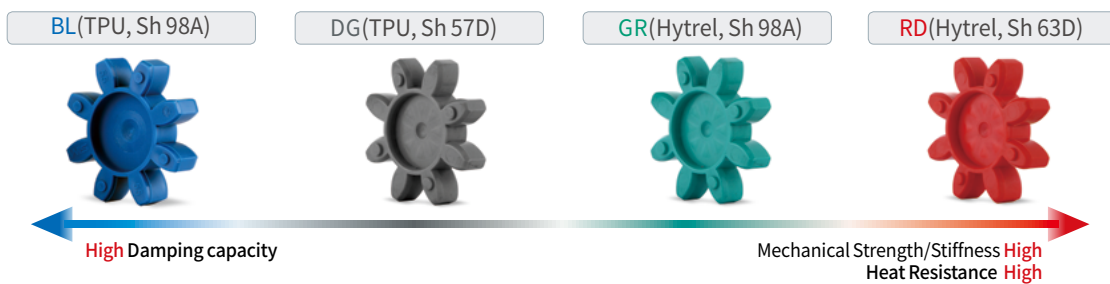

- A Sleeve (Spider) is the medium that transmits motion absorbing impact and misalignment and it is the core part of Jaw couplings.
- Hytrel® is superior in terms of **mechanical strength, abrasion resistance and heat resistance** whereas TPU (Thermoplastic polyurethane) has higher **damping capacity**.
- According to material and shore hardness, there are 4 types of sleeves, **RD**(Hytrel, Sh 63D), **GR**(Hytrel, Sh 98A), **DG**(TPU, Sh 57D), and **BL**(TPU, Sh 98A) respectively.

### ※ Made-to-Order (Customization) Support

- Connection method and fit tolerance can be customized.
- Balancing tab machining is available for high-speed rotation.
- Material, geometry, surface treatment, and other specifications can be customized.



# SJC SERIES (SJCP-T)

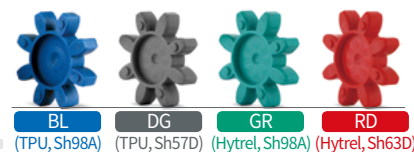

Jaw Coupling (For High-Precision, High-Speed Spindles)

## Taper-ring (For High-Precision, High-Speed Spindles)

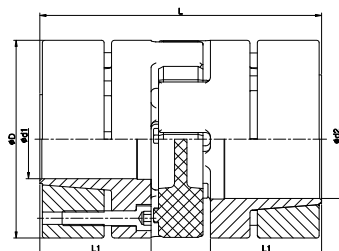

### Dimensions / Performance

Model	Size (±0.3mm)			d1, d2 (mm)		Screws			Rated Torque (N·m)	Max. Torque (N·m)	Moment of Inertia (kg·m <sup>2</sup> )	Static Torsional Stiffness (N·m/rad)	Mass (g)	Permissible Misalignment		
	D	L	L1	Min.	Max.	Size	The no. of Screws	Fastening Torque (N·m)						Angular (°)	Parallel (mm)	End-play (mm)
SJCP-55T-BL-TH	55	78	30	14	28	M5	4	8	60	120	4.11×10 <sup>4</sup>	3,000	850	1	0.09	-0.5 ~ +1.4
SJCP-55T-DG-TH	55	78	30	14	28	M5	4	8	60	120	4.11×10 <sup>4</sup>	4,500	850	1	0.08	-0.5 ~ +1.4
SJCP-55T-GR-TH	55	78	30	14	28	M5	4	8	60	120	4.11×10 <sup>4</sup>	4,500	850	1	0.09	-0.5 ~ +1.4
SJCP-55T-RD-TH	55	78	30	14	28	M5	4	8	75	150	4.11×10 <sup>4</sup>	6,000	850	1	0.06	-0.5 ~ +1.4
SJCP-65T-BL-TH	65	90	35	15	38	M5	8	8	150	300	8.76×10 <sup>4</sup>	6,500	1,240	1	0.1	-0.6 ~ +1.5
SJCP-65T-DG-TH	65	90	35	15	38	M5	8	8	150	300	8.76×10 <sup>4</sup>	8,500	1,240	1	0.09	-0.6 ~ +1.5
SJCP-65T-GR-TH	65	90	35	15	38	M5	8	8	150	300	8.76×10 <sup>4</sup>	8,500	1,240	1	0.1	-0.6 ~ +1.5
SJCP-65T-RD-TH	65	90	35	15	38	M5	8	8	180	360	8.76×10 <sup>4</sup>	10,000	1,240	1	0.08	-0.6 ~ +1.5
SJCP-80T-BL-TH	80	114	45	20	45	M6	8	13	300	600	2.58×10 <sup>3</sup>	8,000	2,380	1	0.1	-0.6 ~ +1.5
SJCP-80T-DG-TH	80	114	45	20	45	M6	8	13	300	600	2.58×10 <sup>3</sup>	12,000	2,380	1	0.09	-0.6 ~ +1.5
SJCP-80T-GR-TH	80	114	45	20	45	M6	8	13	300	600	2.58×10 <sup>3</sup>	12,000	2,380	1	0.1	-0.6 ~ +1.5
SJCP-80T-RD-TH	80	114	45	20	45	M6	8	13	380	760	2.58×10 <sup>3</sup>	14,000	2,380	1	0.08	-0.6 ~ +1.5
SJCP-90T-BL-TH	95	126	50	25	50	M8	4	30	450	900	5.93×10 <sup>3</sup>	12,000	4,090	1	0.15	-0.6 ~ +2.0
SJCP-90T-DG-TH	95	126	50	25	50	M8	4	30	450	900	5.93×10 <sup>3</sup>	14,000	4,090	1	0.12	-0.6 ~ +2.0
SJCP-90T-GR-TH	95	126	50	25	50	M8	4	30	450	900	5.93×10 <sup>3</sup>	14,000	4,090	1	0.15	-0.6 ~ +2.0
SJCP-90T-RD-TH	95	126	50	25	50	M8	4	30	500	1,000	5.93×10 <sup>3</sup>	16,000	4,090	1	0.1	-0.6 ~ +2.0
SJCP-100T-BL-TH	104	140	56	30	55	M10	4	50	500	1,000	9.68×10 <sup>3</sup>	24,000	5,540	1	0.15	-0.6 ~ +2.0
SJCP-100T-DG-TH	104	140	56	30	55	M10	4	50	500	1,000	9.68×10 <sup>3</sup>	24,000	5,540	1	0.12	-0.6 ~ +2.0
SJCP-100T-GR-TH	104	140	56	30	55	M10	4	50	500	1,000	9.68×10 <sup>3</sup>	30,000	5,540	1	0.15	-0.6 ~ +2.0
SJCP-100T-RD-TH	104	140	56	30	55	M10	4	50	600	1,200	9.68×10 <sup>3</sup>	40,000	5,540	1	0.1	-0.6 ~ +2.0

The SJCP series is supplied on a made-to-order basis, and the above specification table is for reference only.

### HOW TO ORDER

#### Taper-ring (For High-Precision, High-Speed Spindles)

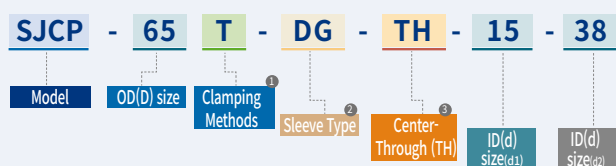

- 1 Clamping Methods
  - T Taper-ring
- 2 Sleeve Type (Shore Hardness)
  - RD Hytrel, Sh63D
  - GR Hytrel, Sh98A
  - DG TPU, Sh57D
  - BL TPU, Sh98A
- 3 Center-Through
  - No mark Center-Solid
  - TH Center-Through

# SOH SERIES



## Oldham Coupling

### SOH Series Classification

SOH series transmits motion through the middle spacer and is particularly excellent for absorption of parallel misalignment. It has a simple structure for easier self-maintenance. It enables reaction force on the shaft to be reduced by moving the spacer even though there is parallel misalignment. Sung-il Machinery provides various spacer types which are allowed to be used in special circumstances.

Spacer Material	Model	Hub Material	Set-screw	Side-clamp
Polyacetal(POM) / General	SOH	High Strength Aluminum Alloy		
	SOHM (Spacer-saving)		-	
PEEK / For Vacuum application	SOHMP		-	
VESPEL(PI) / For High-temperature application	SOHSV	Stainless Steel	-	

### Center-Through Spacer Option is available



- If the shaft has to be inserted deeper than L<sub>1</sub> value, we can provide appropriate center-through sleeves.
- Please indicate additional mark (TH) next to the part no. Please refer to "HOW TO ORDER" for more details.
- Due to the structural characteristics of the center-through (TH) type spacer, slight variations in static torsional stiffness values may occur.
- Center-Through (TH) is standard for the following models, SOH-6,8,10,12, SOHM-12C, SOH□-70□, SOH-90C, SOH-120C and all sizes of SOHMP, SOHSV.
- The standard color of spacer for SOH-6, 8, 10, 12 is white, but the material is the identical Polyacetal(POM).

Model	Max. standard ID	Spacer-TH ID
SOH-16	Φ6	Φ7
SOH-20	Φ8	Φ10
SOH-25	Φ10	Φ14
SOH-32	Φ15	Φ16
SOH-43	Φ19	Φ21
SOH-53	Φ25	Φ24
SOH-57	Φ28	Φ26
SOH-70	Φ40	Φ35
SOH-90	Φ50	Φ40
SOH-120	Φ60	Φ50

# SOH SERIES

## Oldham Coupling

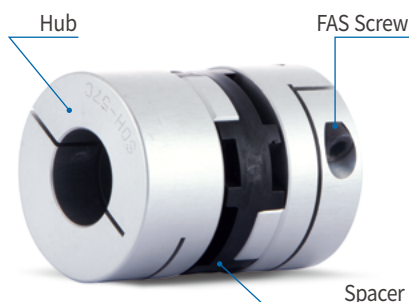

### Structure and Material

Structure	Material	Surface Treatment
Hub	High Strength Aluminum Alloy	Anodizing
Spacer	Polyacetal(POM)	-
Screw	SCM435	Black Oxide

※ There is no surface treatment for SOH-6,8,10,12 (Set-screw) and SOHM-12C(Side-clamp).

### Product Features & Application

High Torque (Durability)		○
Torsional Stiffness		△
Vibration Absorption		○
Misalignment Absorption		☆
Insulation of Electric Current		○
Minimized Reaction Force		☆
Oil Resistance		△
Applicable Motors	Servo	△
	Stepping	○
	Encoder	○
	General	☆
Permissible Temperature		-20°C ~ 80°C

Application : Part feeder, Cartesian Robot, Logistics facilities

### Temperature Correction Factor

- Please modify rated/max. torque value with the below temperature correction factor when it's higher than 30°C.

Ambient Temperature	Correction Factor
-20 °C ~ 30 °C	1.0
30 °C ~ 40 °C	0.8
40 °C ~ 60 °C	0.7
60 °C ~ 80 °C	0.55

### Clamping Methods

Set-screw (No mark)	General	△
	With Keyway	△
Side-clamp (C)	General	△
	Hub Split	△
	With Keyway	△
Taper-ring (T)		X

※ You may check the sizes that Side-clamp Hub Split type is applicable from the "Dimensions / Performance" tables in the following pages.

### How to Order

**SOH - 70 CW - TH - 20 W K6 x 25 W K8**

<b>1 Clamping Methods</b> No mark Set-screw C General Side-clamp CW Side-clamp Hub Split		<b>2 Center-Through</b> No mark Center-Solid TH Center-Through	
<b>3 Side-clamp Hub Split</b> No mark Not Split W Split (Only applicable on Side-clamp Type)		<b>4 Keyway</b> No mark No Keyway K(b size) Keyway processed according to the indicated b size.	

# SOH SERIES

## Oldham Coupling

### Set-screw

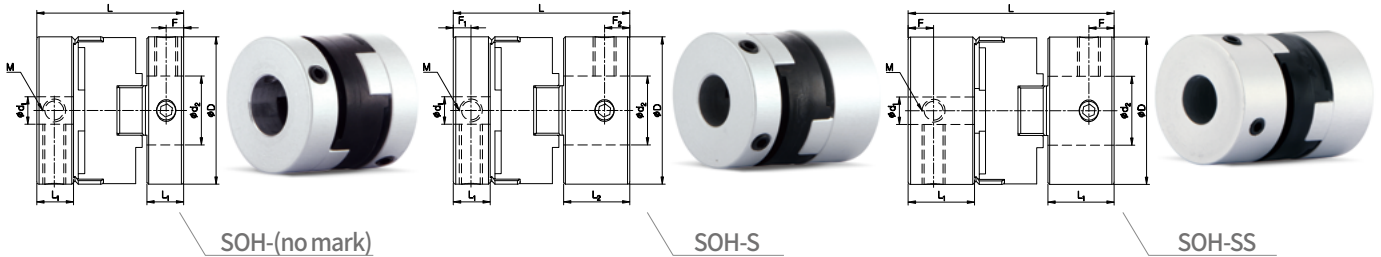

### Dimensions / Performance

#### SOH-(no mark)

Model	Size ( $\pm 0.3\text{mm}$ )				Screw		Rated Torque (N·m)	Max. Torque (N·m)	Max. rpm ( $\text{min}^{-1}$ )	Moment of Inertia ( $\text{kg}\cdot\text{m}^2$ )	Static Torsional Stiffness (N·m/rad)	Mass (g)	Permissible Misalignment		
	D	L	L <sub>1</sub>	F	Size	Fastening Torque (N·m)							Angular (°)	Parallel (mm)	End-play (mm)
SOH-6	5.9	8.4	2.5	1.3	M2	0.3	0.2	0.4	22,000	$2.5 \times 10^{-9}$	5	0.5	1.5	0.5	0.05
SOH-8	7.9	9.8	2.5	1.3	M2	0.3	0.5	1	20,000	$8.4 \times 10^{-9}$	10	0.9	1.5	0.7	0.05
SOH-10	9.9	10.4	2.9	1.5	M2	0.3	0.7	1.4	18,000	$2.4 \times 10^{-8}$	25	1.7	1.5	0.9	0.05
SOH-12	11.9	14.5	3.9	2	M3	0.7	0.9	1.8	15,000	$6.3 \times 10^{-8}$	55	3	1.5	1	0.05
SOH-16	16	17.9	4.7	2.2	M3	0.7	1	2	13,000	$2.4 \times 10^{-7}$	65	7	1.5	1	0.1
SOH-20	20	19.9	5.1	2.4	M4	1.7	1.5	3	11,000	$6.4 \times 10^{-7}$	120	12	1.5	1.5	0.1
SOH-25	25.5	25.4	6.9	3.1	M4	1.7	2.5	5	10,000	$2.2 \times 10^{-6}$	200	24	1.5	2	0.1
SOH-32	32	31.9	8	3.8	M5	4	7	14	9,000	$6.3 \times 10^{-6}$	620	41	1.5	2.5	0.2
SOH-43	43	52	16.5	7.1	M5	4	12.5	25	8,000	$3.7 \times 10^{-5}$	1,200	135	1.5	3	0.15
SOH-53	53	58.3	19.5	7.5	M6	7	20	40	7,000	$1.0 \times 10^{-4}$	1,400	228	1.5	3.2	0.15
SOH-57	57	76.2	26.9	9.9	M8	15	34	68	6,000	$1.8 \times 10^{-4}$	2,600	345	1.5	3.5	0.2
SOH-70	73	75.5	25	12.2	M8	15	65	130	4,500	$4.5 \times 10^{-4}$	5,000	567	1.5	3.5	0.2

#### SOH-S

Model	Size ( $\pm 0.3\text{mm}$ )						Screw		Rated Torque (N·m)	Max. Torque (N·m)	Max. rpm ( $\text{min}^{-1}$ )	Moment of Inertia ( $\text{kg}\cdot\text{m}^2$ )	Static Torsional Stiffness (N·m/rad)	Mass (g)	Permissible Misalignment		
	D	L	L <sub>1</sub>	L <sub>2</sub>	F <sub>1</sub>	F <sub>2</sub>	Size	Fastening Torque (N·m)							Angular (°)	Parallel (mm)	End-play (mm)
SOH-16S	16	20.9	4.7	7.7	2.2	3.8	M3	0.7	1	2	13,000	$2.7 \times 10^{-7}$	65	7.9	1.5	1	0.1
SOH-20S	20	22.8	5.1	8	2.4	3.6	M4	1.7	1.5	3	11,000	$7.5 \times 10^{-7}$	120	13	1.5	1.5	0.1
SOH-25S	25.5	28.7	6.9	10.2	3.1	4.9	M4	1.7	2.5	5	10,000	$2.6 \times 10^{-6}$	200	27.2	1.5	2	0.1
SOH-32S	32	38.3	8	14.4	3.8	5.5	M5	4	7	14	9,000	$8.1 \times 10^{-6}$	620	52	1.5	2.5	0.2

#### SOH-SS

Model	Size ( $\pm 0.3\text{mm}$ )				Screw		Rated Torque (N·m)	Max. Torque (N·m)	Max. rpm ( $\text{min}^{-1}$ )	Moment of Inertia ( $\text{kg}\cdot\text{m}^2$ )	Static Torsional Stiffness (N·m/rad)	Mass (g)	Permissible Misalignment		
	D	L	L <sub>1</sub>	F	Size	Fastening Torque (N·m)							Angular (°)	Parallel (mm)	End-play (mm)
SOH-8SS	7.9	12.6	4.6	2.3	M3	0.7	0.5	1	20,000	$1.3 \times 10^{-8}$	10	1.5	1.5	0.7	0.05
SOH-16SS	16	23.9	7.7	3.8	M3	0.7	1	2	13,000	$3.4 \times 10^{-7}$	65	9.3	1.5	1	0.1
SOH-20SS	20	25.7	8	3.6	M4	1.7	1.5	3	11,000	$8.9 \times 10^{-7}$	120	15	1.5	1.5	0.1
SOH-25SS	25.5	32	10.2	4.9	M4	1.7	2.5	5	10,000	$2.9 \times 10^{-6}$	200	31	1.5	2	0.1
SOH-32SS	32	44.7	14.4	5.5	M5	4	7	14	9,000	$9.5 \times 10^{-6}$	620	63	1.5	2.5	0.2

- The Moment of Inertia and Mass values are based on products with max. Inner diameter.
- Please modify rated/max. torque value with temperature correction factor when it's higher than 30°C.
- Max. torque/rated torque is the value regarding to a coupling's self-durability and is not related to slip-torque between the coupling bore and the shaft. (Set-screw type is usually less durable than other clamping method, thus please consider it has a complementary option e.g. keyway along with.)

# SOH SERIES

## Oldham Coupling

### Standard Inner Diameter (ID)

Model	Standard Inner Diameter ( $d_1, d_2$ ) (mm)																	
	1	1.5	2	2.5	3	4	4.5	5	6	6.35	8	9	9.525	10	11	12	14	15
SOH-6□□	●	●	●															
SOH-8□□	●		●	●	●													
SOH-10□□			●		●	●												
SOH-12□□					●	●	●	●										
SOH-16□□					●	●		●	●									
SOH-20□□						●		●	●	●	●							
SOH-25□□								●	●	●	●	●	●	●				
SOH-32□□									●	●	●	●	●	●	●	●	●	●

Model	Standard Inner Diameter ( $d_1, d_2$ ) (mm)																			
	8	9	9.525	10	11	12	14	15	16	18	19	20	22	24	25	25.4	28	30	32	35
SOH-43□□	●	●	●	●	●	●	●	●	●	●	●									
SOH-53□□				●	●	●	●	●	●	●	●	●	●	●	●					
SOH-57□□								●	●	●	●	●	●	●	●	●	●			
SOH-70								●	●	●	●	●	●	●	●	●	●	●	●	●

- The recommended shaft tolerance is h7.
- Custom process (e.g. non-standard Inner diameter, special tolerance etc.) is also available upon a special request in prior to order placement.  
(※ Exception Item: SOH-6□□, SOH-8□□, SOH-10□□, SOH-12□□)
- Keyway is available. (Optional)

# SOH SERIES

## Oldham Coupling

### Side-clamp

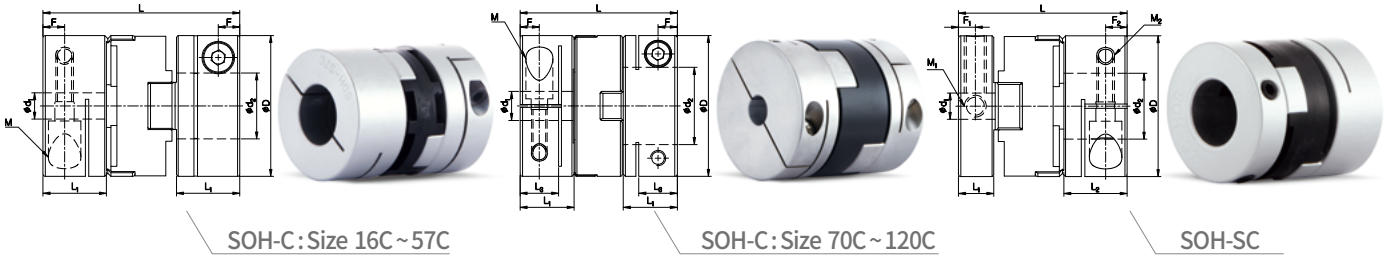

### Dimensions / Performance

#### SOH-C

Model	Size (±0.3mm)					Screw		Rated Torque (N·m)	Max. Torque (N·m)	Max. rpm (min <sup>-1</sup> )	Moment of Inertia (kg·m <sup>2</sup> )	Static Torsional Stiffness (N·m/rad)	Mass (g)	Permissible Misalignment			Side-clamp Hub Split (W)
	D	L	L <sub>1</sub>	L <sub>3</sub>	F	Size	Fastening Torque (N·m)							Angular (°)	Parallel (mm)	End-play (mm)	
SOH-16C	16	23.9	7.7	-	2.7	M2.6	1	1	2	13,000	3.1×10 <sup>-7</sup>	65	8.5	1.5	1	0.1	X
SOH-20C	20	25.7	8	-	2.8	M2.6	1	1.5	3	11,000	8.2×10 <sup>-7</sup>	120	14.2	1.5	1.5	0.1	X
SOH-25C	25.5	32	10.2	-	3.5	M3	1.7	2.5	5	10,000	2.7×10 <sup>-6</sup>	200	29.3	1.5	2	0.1	X
SOH-32C	32	44.7	14.4	-	4.9	M4	3.5	7	14	9,000	9.2×10 <sup>-6</sup>	620	59.6	1.5	2.5	0.15	X
SOH-43C	43	52	16.5	-	5.8	M5	8	12.5	25	8,000	3.4×10 <sup>-5</sup>	1,200	127	1.5	3	0.15	X
SOH-53C	53	58.3	19.5	-	6.3	M5	8	20	40	7,000	9.1×10 <sup>-5</sup>	1,400	217	1.5	3.2	0.2	X
SOH-57C	57	76.2	26.9	-	7.7	M6	13	34	68	6,000	1.6×10 <sup>-4</sup>	2,600	329	1.5	3.5	0.2	X
SOH-70C	73	81.5	28	20	10	M8	30	65	130	4,500	5.4×10 <sup>-4</sup>	5,000	670	1.5	3.5	0.3	○
SOH-90C	88	97	33.5	25	12	M10	50	105	210	4,500	1.2×10 <sup>-3</sup>	7,500	1,240	1.5	4	0.35	○
SOH-120C	118	138	40.5	26.5	13	M12	90	200	400	3,500	6.5×10 <sup>-3</sup>	14,000	2,600	1.5	4.5	0.4	○

- The Moment of Inertia and Mass values are based on products with max. Inner diameter.
- Please modify rated/max. torque value with temperature correction factor when it's higher than 30°C.
- Max. torque/rated torque is the value regarding to a coupling's self-durability and is not related to slip-torque between the coupling bore and the shaft.

#### SOH-SC (Combination)

Model	Size (±0.3mm)						Screw				Rated Torque (N·m)	Max. Torque (N·m)	Max. rpm (min <sup>-1</sup> )	Moment of Inertia (kg·m <sup>2</sup> )	Static Torsional Stiffness (N·m/rad)	Mass (g)	Permissible Misalignment		
	D	L	L <sub>1</sub>	L <sub>2</sub>	F <sub>1</sub>	F <sub>2</sub>	Size (M <sub>1</sub> )	Fastening Torque (N·m)	Size (M <sub>2</sub> )	Fastening Torque (N·m)							Angular (°)	Parallel (mm)	End-play (mm)
SOH-16SC	16	20.9	4.7	7.7	2.2	2.7	M3	0.7	M2.6	1	1	2	13,000	2.9×10 <sup>-7</sup>	65	7.5	1.5	1	0.1
SOH-20SC	20	22.8	5.1	8	2.4	2.8	M4	1.7	M2.6	1	1.5	3	11,000	7.2×10 <sup>-7</sup>	120	12.6	1.5	1.5	0.1
SOH-25SC	25.5	28.7	6.9	10.2	3.1	3.5	M4	1.7	M3	1.7	2.5	5	10,000	2.6×10 <sup>-6</sup>	200	26	1.5	2	0.1
SOH-32SC	32	38.3	8	14.4	3.8	4.9	M5	4	M4	3.5	7	14	9,000	7.8×10 <sup>-6</sup>	620	50.3	1.5	2.5	0.2

- The Moment of Inertia and Mass values are based on products with max. Inner diameter.
- Please modify rated/max. torque value with temperature correction factor when it's higher than 30°C.
- Max. torque/rated torque is the value regarding to a coupling's self-durability and is not related to slip-torque between the coupling bore and the shaft.
- The values about Screw (size and fastening torque) are stated in left-to-right order. (S/C=Set-screw/Side-clamp)

# SOH SERIES

## Oldham Coupling

### Standard Inner Diameter (ID)

Model	Standard Inner Diameter (d <sub>1</sub> , d <sub>2</sub> ) (mm)																															
	3	4	5	6	6.35	8	9	9.525	10	11	12	14	15	16	18	19	20	22	24	25	25.4	28	30	32	35	40	42	45	50	55	60	
SOH-16□□	●	●	●	●																												
SOH-20□□		●	●	●	●	●																										
SOH-25□□			●	●	●	●	●	●	●																							
SOH-32□□				●	●	●	●	●	●	●	●	●	●																			
SOH-43□□						●	●	●	●	●	●	●	●	●	●	●																
SOH-53□□									●	●	●	●	●	●	●	●	●	●	●	●	●	●										
SOH-57□□												●	●	●	●	●	●	●	●	●	●	●	●	●	●	●	●	●	●	●	●	
SOH-70□□												●	●	●	●	●	●	●	●	●	●	●	●	●	●	●	●	●	●	●	●	
SOH-90□□																	●	●	●	●	●	●	●	●	●	●	●	●	●	●	●	
SOH-120□□																				●	●	●	●	●	●	●	●	●	●	●	●	

- The recommended shaft tolerance is h7.
- Custom process (e.g. non-standard Inner diameter, special tolerance etc.) is also available upon a special request in prior to order placement.
- Keyway is available. (Optional)

### Slip Torque

- The below table shows the actual permissible torque values when the slip torque value is lower than the coupling's max. torque value.
- If the slip torque value is lower than the coupling's max. torque value, please check and compare between the slip torque in the below table and the operating torque value of the connected motor. It is safer to size up the coupling or use a key/keyway when the slip torque value is lower than the motor's operating torque.
- The below slip torque values may be subject to change according to different testing conditions. (e.g. shaft tolerance, surface roughness, surface treatment or acceleration/deceleration of driving shafts). On the other hand, the values could be affected when a different kind of fastening screw is used (body material or surface treatment). Therefore, we recommend you test under the same conditions before mounting.

Model	Max. Torque (N.m)	Slip Torque (N.m) by Inner Diameter (d <sub>1</sub> , d <sub>2</sub> )																												
		3	4	5	6	6.35	8	9.525	10	11	12	14	15	16	18	19	20	22	24	25	28	30	35	40	42	45	50			
SOH-16C	2	0.5	1																											
SOH-20C	3		1	2.9																										
SOH-25C	5			3	4.5																									
SOH-32C	14				5.5	6.5	8	10	11	12																				
SOH-43C	25						22																							
SOH-53C	40								25	30																				
SOH-57C	68												42	55	65															
SOH-70C	130																													
SOH-90C	210																	150	180											
SOH-120C	400																					200	250	275	300	320	330	350	380	

# SOH SERIES (SOHM)

## Oldham Coupling

### Side-clamp (Spacer-saving)

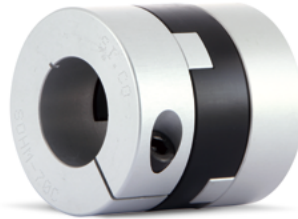
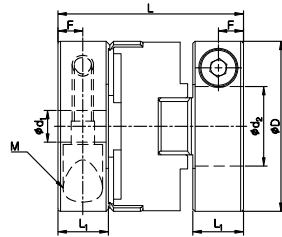

### Dimensions / Performance

Model	Size (±0.3mm)				Screw		Rated Torque (N·m)	Max. Torque (N·m)	Max. rpm (min <sup>-1</sup> )	Moment of Inertia (kg·m <sup>2</sup> )	Static Torsional Stiffness (N·m/rad)	Mass (g)	Permissible Misalignment		
	D	L	L <sub>1</sub>	F	Size	Fastening Torque (N·m)							Angular (°)	Parallel (mm)	End-play (mm)
SOHM-12C	11.9	16.5	5	2.5	M2	0.5	0.9	1.8	15,000	7.4 × 10 <sup>-8</sup>	55	3.5	1.5	1	0.05
SOHM-16C	16	20.7	6.1	3	M2.6	1	1	2	13,000	2.6 × 10 <sup>-7</sup>	65	7.4	1.5	1	0.1
SOHM-20C	20	21.9	6.1	2.9	M2.6	1	1.5	3	11,000	6.8 × 10 <sup>-7</sup>	120	12	1.5	1.5	0.1
SOHM-25C	25.5	26.4	7.4	3.7	M3	1.7	2.5	5	10,000	2.2 × 10 <sup>-6</sup>	200	23	1.5	2	0.1
SOHM-32C	32	34.9	9.5	4.7	M4	3.5	7	14	9,000	6.8 × 10 <sup>-6</sup>	620	44	1.5	2.5	0.2
SOHM-43C	43	47	14	7	M5	8	12.5	25	8,000	3.0 × 10 <sup>-5</sup>	1,200	114	1.5	3	0.15
SOHM-53C	53	53.1	16.9	8.3	M5	8	20	40	7,400	8.3 × 10 <sup>-5</sup>	1,400	197	1.5	3.2	0.15
SOHM-57C	57	56.8	17.2	8.5	M6	13	34	68	6,000	1.2 × 10 <sup>-4</sup>	2,600	232	1.5	3.5	0.2
SOHM-70C	73	75.5	25	12.3	M8	30	65	130	4,500	4.5 × 10 <sup>-4</sup>	5,000	547	1.5	3.5	0.2

- The Moment of Inertia and Mass values are based on products with max. Inner diameter.
- Please modify rated/max. torque value with temperature correction factor when it's higher than 30°C.
- Max. torque/rated torque is the value regarding to a coupling's self-durability and is not related to slip-torque between the coupling bore and the shaft.

### Standard Inner Diameter (ID)

Model	Standard Inner Diameter (d <sub>1</sub> , d <sub>2</sub> ) (mm)																										
	3	4	4.5	5	6	6.35	8	9	9.525	10	11	12	14	15	16	18	19	20	22	24	25	25.4	28	30	32	35	
SOHM-12C	●	●	●	●																							
SOHM-16C	●	●		●	●																						
SOHM-20C		●		●	●	●	●																				
SOHM-25C				●	●	●	●	●	●	●																	
SOHM-32C					●	●	●	●	●	●	●	●	●	●													
SOHM-43C							●	●	●	●	●	●	●	●	●	●	●										
SOHM-53C										●	●	●	●	●	●	●	●	●	●	●	●	●					
SOHM-57C														●	●	●	●	●	●	●	●	●	●	●	●	●	●
SOHM-70C														●	●	●	●	●	●	●	●	●	●	●	●	●	●

- The recommended shaft tolerance is h7.
- Custom process (e.g. non-standard Inner diameter, special tolerance etc.) is also available upon a special request in prior to order placement.
- Keyway is available. (Optional)

# SOH SERIES (SOHM)

## Oldham Coupling

### Slip Torque

- The below table shows the actual permissible torque values when the slip torque value is lower than the coupling's max. torque value.
- If the slip torque value is lower than the coupling's max. torque value, please check and compare between the slip torque in the below table and the operating torque value of the connected motor. It is safer to size up the coupling or use a key/keyway when the slip torque value is lower than the motor's operating torque.
- The below slip torque values may be subject to change according to different testing conditions. (e.g. shaft tolerance, surface roughness, surface treatment or acceleration/deceleration of driving shafts). On the other hand, the values could be affected when a different kind of fastening screw is used (body material or surface treatment). Therefore, we recommend you test under the same conditions before mounting.

Model	Max. Torque (N.m)	Slip Torque (N.m) by Inner Diameter (d <sub>1</sub> , d <sub>2</sub> )																	
		3	4	4.5	5	6	6.35	8	9.525	10	11	12	14	15	16	18	19	20	22
SOHM-12C	1.8	0.5	0.6	1	1.2														
SOHM-16C	2	0.6	0.6																
SOHM-20C	3		1		2.7														
SOHM-25C	5				3	4	4.5												
SOHM-32C	14					5	5.5	7.5	9	10	11								
SOHM-43C	25							24											
SOHM-53C	40									30	35								
SOHM-57C	68													50	55				
SOHM-70C	130													110	115				

# SOH SERIES (SOHMP)

## Oldham Coupling (PEEK Spacer)

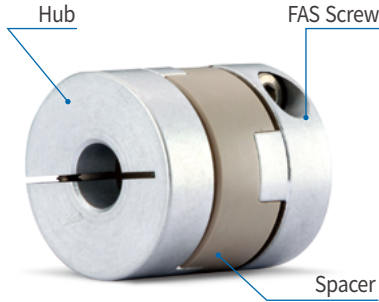

### Structure and Material

Structure	Material	Surface Treatment
Hub	High Strength Aluminum Alloy	-
Spacer	PEEK	-
Screw	STS304	-

### Product Features & Application

Minimized Outgas	☆
High Torque (Durability)	○
Torsional Stiffness	△
Chemical Resistance	○
Misalignment Absorption	☆
Insulation of Electric Current	☆
Minimized Reaction Force	☆
Permissible Temperature	-20°C ~ 120°C

**Application :** Semi-conductor machine, OLED vacuum machine, High-temperature applications, cleanroom facilities.

### Features of SOHMP Series

- Excellent for Vacuum applications in regards of extremely low level of outgas. (In terms of outgas, SOHMP performs better than SOHSV Series)
- Suitable to be used in cleanroom facilities and high-temperature applications.

### Properties of PEEK Material

	Item	Test Method	Value	Unit
Physical Properties	Density	ISO 1183-1	1.31	g/cm <sup>3</sup>
	Heat Deflection Temperature (1.8 MPa)	ISO 75-1	160	°C
Thermal Properties	Coefficient of Thermal Expansion (23 - 150°C)	-	55×10 <sup>-6</sup>	m/m·K
	Tensile Strength	ISO 527-1	115	MPa
Mechanical Properties	Elongation at yield	ISO 527-1	5	%
	Rockwell Hardness	ISO 2039-2	M105	

### How to Order

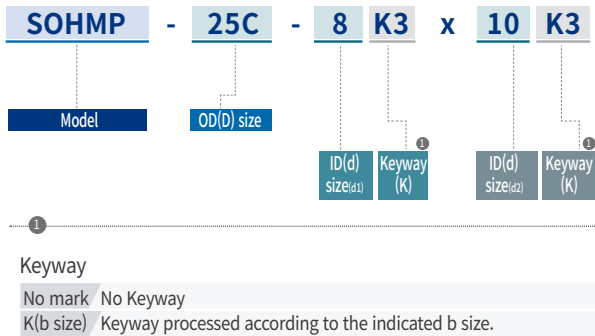

# SOH SERIES (SOHMP)

## Oldham Coupling (PEEK Spacer)

### Side-clamp

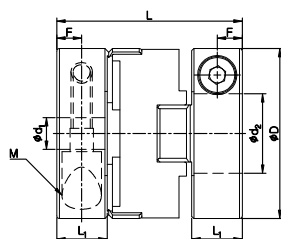

### Dimensions / Performance

Model	Size ( $\pm 0.3\text{mm}$ )				Screw		Rated Torque (N·m)	Max. Torque (N·m)	Max. rpm ( $\text{min}^{-1}$ )	Moment of Inertia ( $\text{kg}\cdot\text{m}^2$ )	Static Torsional Stiffness (N·m/rad)	Mass (g)	Permissible Misalignment		
	D	L	L <sub>1</sub>	F	Size	Fastening Torque (N·m)							Angular (°)	Parallel (mm)	End-play (mm)
SOHMP-20C	20	21.9	6.1	2.9	M2.6	1	1	2	11,000	$6.8 \times 10^{-7}$	80	12	1.5	1.5	0.1
SOHMP-25C	25.5	26.4	7.4	3.7	M3	1.7	1.5	3	10,000	$2.2 \times 10^{-6}$	120	23	1.5	2	0.1
SOHMP-32C	32	34.9	9.5	4.7	M4	3.5	3	6	9,000	$6.8 \times 10^{-6}$	300	44	1.5	2.5	0.2
SOHMP-43C	43	47	14	7	M5	8	5	10	8,000	$3.0 \times 10^{-5}$	1,000	114	1.5	3	0.15

- The Moment of Inertia and Mass values are based on products with max. Inner diameter.
- Max. torque/rated torque is the value regarding to a coupling's self-durability and is not related to slip-torque between the coupling bore and the shaft.

### Standard Inner Diameter (ID)

Model	4	5	6	6.35	8	9	9.525	10	11	12	14	15	16	18	19
SOHMP-20C	●	●	●	●	●										
SOHMP-25C		●	●	●	●	●	●	●							
SOHMP-32C			●	●	●	●	●	●	●	●	●	●			
SOHMP-43C					●	●	●	●	●	●	●	●	●	●	●

- The recommended shaft tolerance is h7.
- Custom process (e.g. non-standard Inner diameter, special tolerance etc.) is also available upon a special request in prior to order placement.
- Keyway is available. (Optional)

# SOH SERIES (SOHSV)

## Oldham Coupling (VESPEL Spacer)

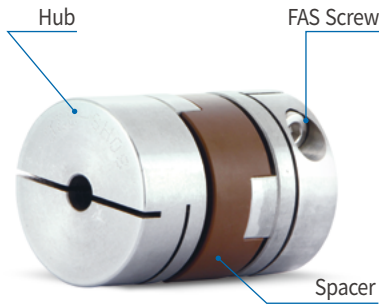

### Structure and Material

Structure	Material	Surface Treatment
Hub	Stainless Steel	Electro-polishing
Spacer	VESPEL (PI)	-
Screw	STS304	-

### Product Features & Application

Minimized Outgas	☆
High Torque (Durability)	○
Torsional Stiffness	△
Chemical Resistance	○
Misalignment Absorption	☆
Insulation of Electric Current	☆
Minimized Reaction Force	☆
Permissible Temperature	-20°C ~ 200°C

**Application :** Semi-conductor machine, OLED vacuum machine, High-temperature applications, cleanroom facilities.

### Features of SOHSV Series

- Excellent for high-temperature applications in regards of heat resistance.
- Outgas amount is relatively lower and it's ideal to be used in cleanroom facilities and vacuum applications.

### Properties of VESPEL Material

	Item	Test Method	Value	Unit
Physical Properties	Density	ISO 1183-1	1.43	g/cm <sup>3</sup>
	Heat Deflection Temperature (1.8 MPa)	ISO 75-1	340	°C
Thermal Properties	Coefficient of Thermal Expansion (23 - 300°C)	-	45×10 <sup>-6</sup>	m/m·K
	Tensile Strength	ISO 527-1	163	MPa
Mechanical Properties	Elongation at yield	ISO 527-1	7.5	%
	Rockwell Hardness	ISO 2039-2	E95	

### How to Order

**SOHSV** - **25C** - **8 K3** x **10 K3**

Model      OD(D) size      ID(d) size<sub>(d1)</sub>      Keyway (K)      ID(d) size<sub>(d2)</sub>      Keyway (K)

Keyway  
 No mark      No Keyway  
 K(b size)      Keyway processed according to the indicated b size.

# SOH SERIES (SOHSV)

## Oldham Coupling (VESPEL Spacer)

### Side-clamp

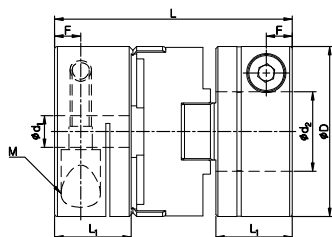

### Dimensions / Performance

Model	Size ( $\pm 0.3\text{mm}$ )				Screw		Rated Torque (N·m)	Max. Torque (N·m)	Max. rpm ( $\text{min}^{-1}$ )	Moment of Inertia ( $\text{kg}\cdot\text{m}^2$ )	Static Torsional Stiffness (N·m/rad)	Mass (g)	Permissible Misalignment		
	D	L	L <sub>1</sub>	F	Size	Fastening Torque (N·m)							Angular (°)	Parallel (mm)	End-play (mm)
SOHSV-20C	20	25.7	8	2.8	M2.6	1	0.8	1.6	11,000	$1.7 \times 10^{-6}$	96	31	1.5	1.5	0.1
SOHSV-25C	25.5	32	10.2	3.5	M3	1.5	1.4	2.7	10,000	$5.7 \times 10^{-6}$	144	62	1.5	2	0.1
SOHSV-32C	32	44.7	14.4	4.9	M4	2.5	3.8	7.6	9,000	$1.8 \times 10^{-5}$	360	125	1.5	2.5	0.2

- The Moment of Inertia and Mass values are based on products with max. Inner diameter.
- Max. torque/rated torque is the value regarding to a coupling's self-durability and is not related to slip-torque between the coupling bore and the shaft.

### Standard Inner Diameter (ID)

Model	4	5	6	6.35	8	9	9.525	10	11	12	14	15
SOHSV-20C	●	●	●	●	●							
SOHSV-25C		●	●	●	●	●	●	●				
SOHSV-32C			●	●	●	●	●	●	●	●	●	●

- The recommended shaft tolerance is h7.
- Custom process (e.g. non-standard Inner diameter, special tolerance etc.) is also available upon a special request in prior to order placement.
- Keyway is available. (Optional)

# SRB SERIES



## Radial Beam Coupling (Ultra High Strength Aluminum Alloy Body)

### Structure and Material

#### General



Set-screw (SRB-no mark)



Side-clamp (SRB-C)

Structure	Material	Surface Treatment
Body	AL-7075-T6	Anodizing
Screw	SCM435	Black Oxide

#### Space-saving



Set-screw (SRBM-no mark)



Side-clamp (SRBM-C)

Structure	Material	Surface Treatment
Body	AL-7075-T6	Anodizing
Screw	SCM435	Black Oxide

※ There is no surface treatment for SRB-8 (Set-screw).

### Product Features & Application

- SRB series is one-piece metal coupling with no backlash and absorbs misalignment through its slit structures.
- SRB series is made of ultra high strength aluminum alloy material (AL-7075-T6) in order to enhance its durability.

	SRB	SRBM
Backlash free (Precision)	☆	☆
High Torque (Durability)	△	△
Torsional Stiffness	○	○
Vibration Absorption	-	-
Misalignment Absorption	○	△
Applicable Motors	Servo	○
	Stepping	○
	Encoder	○
	General	-

Application : UVW Stage, XY Stage, Part feeder, Encoder

#### INNER-RELIEF AREA

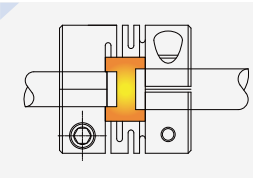

- SRB series has the “relief” space structure in the middle area, in case there is interference that causes damages.

※ Exception Item: SRB-8

#### ROUND-SHAPED SLITS

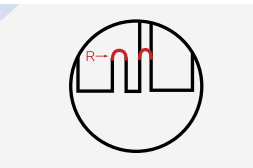

- SRB series has rounded slits(cuts) structure to disperse stress concentration.

### Clamping Methods

Set-screw (No mark)	General	○
	With Keyway	○
Side-clamp (C)	General	△
	Hub Split	X
	With Keyway	△
Taper-ring (T)		X

### How to Order

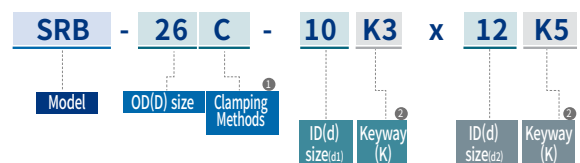

#### 1 Clamping Methods

No mark Set-screw  
C General Side-clamp

#### 2 Keyway

No mark No Keyway  
K(b size) Keyway processed according to the indicated b size.

# SRB SERIES

## Radial Beam Coupling (Ultra High Strength Aluminum Alloy Body)

### Set-screw (SRB-no mark)

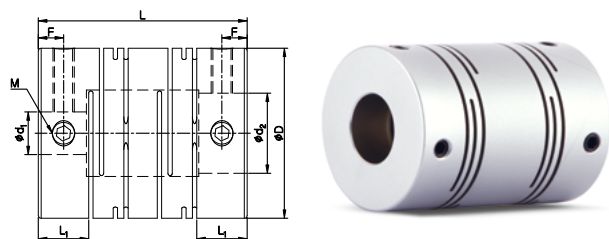

### Side-clamp (SRB-C)

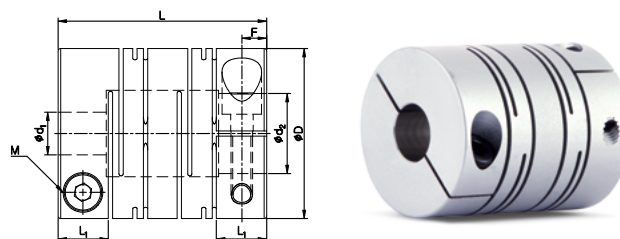

## Dimensions / Performance

### Set-screw

Model	Size ( $\pm 0.3\text{mm}$ )				Screw		Rated Torque (N·m)	Max. Torque (N·m)	Max. rpm ( $\text{min}^{-1}$ )	Moment of Inertia ( $\text{kg}\cdot\text{m}^2$ )	Static Torsional Stiffness (N·m/rad)	Mass (g)	Permissible Misalignment		
	D	L	L <sub>1</sub>	F	Size	Fastening Torque (N·m)							Angular (°)	Parallel (mm)	End-play (mm)
SRB-8	7.9	14	3.5	1.7	M2	0.3	0.1	0.2	50,000	$1.2 \times 10^{-8}$	16	1.5	2.5	0.1	$\pm 0.2$
SRB-12	12.7	18	4.5	2.2	M2.5	0.5	0.2	0.4	40,000	$1.1 \times 10^{-7}$	40	4.4	2.5	0.1	$\pm 0.3$
SRB-16	16	18.5	4.7	2.3	M3	0.7	0.4	0.8	30,000	$2.8 \times 10^{-7}$	75	7.2	2.5	0.15	$\pm 0.3$
SRB-19	19.1	22	6	2.9	M3	0.7	0.6	1.2	24,000	$6.4 \times 10^{-7}$	150	12	2.5	0.15	$\pm 0.3$
SRB-22	22.2	25	6.5	3.2	M4	1.7	1	2	20,000	$1.4 \times 10^{-6}$	200	17.4	2.5	0.15	$\pm 0.4$
SRB-26	26.2	30	7.7	3.4	M4	1.7	2	4	18,000	$3.1 \times 10^{-6}$	340	29.2	2.5	0.2	$\pm 0.4$
SRB-32	31.8	39	9.4	4.7	M5	4	3.8	7.6	18,000	$9.4 \times 10^{-6}$	450	56.8	2.5	0.2	$\pm 0.4$
SRB-39	39	56	16	5.9	M5	4	7	14	12,000	$2.8 \times 10^{-5}$	640	124	2.5	0.25	$\pm 0.4$
SRB-49	49	70	19.8	9.4	M6	7	15	30	10,000	$1.0 \times 10^{-4}$	1,500	280	2.5	0.25	$\pm 0.5$
SRB-60	60	88	19	9	M8	15	30	60	8,500	$2.7 \times 10^{-4}$	2,500	500	2.5	0.3	$\pm 0.5$

- The Moment of Inertia and Mass values are based on products with max. Inner diameter.
- The number of screw for SRB-8 is 1pc and shaft-insertion depth is up to L<sub>1</sub>. (No relief structure)
- Max. torque/rated torque is the value regarding to a coupling's self-durability and is not related to slip-torque between the coupling bore and the shaft. (Set-screw type is usually less durable than other clamping method, thus please consider it has a complementary option e.g. keyway along with.)

### Side-clamp

Model	Size ( $\pm 0.3\text{mm}$ )				Screw		Rated Torque (N·m)	Max. Torque (N·m)	Max. rpm ( $\text{min}^{-1}$ )	Moment of Inertia ( $\text{kg}\cdot\text{m}^2$ )	Static Torsional Stiffness (N·m/rad)	Mass (g)	Permissible Misalignment		
	D	L	L <sub>1</sub>	F	Size	Fastening Torque (N·m)							Angular (°)	Parallel (mm)	End-play (mm)
SRB-12C	12.7	19	5	2.5	M2	0.5	0.2	0.4	35,000	$1.1 \times 10^{-7}$	40	4.4	2.5	0.1	$\pm 0.3$
SRB-16C	16	21.5	6.1	3	M2.6	1	0.4	0.8	27,000	$3.1 \times 10^{-7}$	75	8.2	2.5	0.15	$\pm 0.3$
SRB-19C	19.1	23	6.2	3.1	M2.6	1	0.6	1.2	20,000	$6.4 \times 10^{-7}$	150	12	2.5	0.15	$\pm 0.3$
SRB-22C	22.2	26.5	7.2	3.6	M3	1.7	1	2	18,000	$1.4 \times 10^{-6}$	200	17.9	2.5	0.15	$\pm 0.4$
SRB-26C	26.2	31.5	7.5	3.7	M3	1.7	2	4	17,000	$3.2 \times 10^{-6}$	340	29.9	2.5	0.2	$\pm 0.4$
SRBA-32C	31.8	39	9.4	4.7	M4	3.5	3.8	7.6	14,000	$8.6 \times 10^{-6}$	450	54.9	2.5	0.2	$\pm 0.4$
SRBB-32C	31.8	44	9.4	4.7	M4	3.5	3.8	7.6	14,000	$1.0 \times 10^{-5}$	450	62.3	2.5	0.2	$\pm 0.4$
SRBA-39C	39	43	10.7	5.3	M5	8	7	14	10,000	$2.1 \times 10^{-5}$	640	87.8	2.5	0.25	$\pm 0.4$
SRBB-39C	39	56	12	5.5	M5	8	7	14	10,000	$2.8 \times 10^{-5}$	640	117	2.5	0.25	$\pm 0.4$
SRBA-49C	49	63.5	15.1	7.5	M6	13	15	30	10,000	$8.4 \times 10^{-5}$	1,500	236	2.5	0.25	$\pm 0.5$
SRBB-49C	49	70	14.5	7.2	M6	13	15	30	8,400	$1.0 \times 10^{-4}$	1,500	258	2.5	0.25	$\pm 0.5$
SRBA-60C	60	76.2	19	9.4	M8	30	30	60	7,000	$2.2 \times 10^{-4}$	2,500	407	2.5	0.25	$\pm 0.5$
SRBB-60C	60	88	19	9.4	M8	30	30	60	7,000	$2.6 \times 10^{-4}$	2,500	483	2.5	0.25	$\pm 0.5$

- The Moment of Inertia and Mass values are based on products with max. Inner diameter.
- Max. torque/rated torque is the value regarding to a coupling's self-durability and is not related to slip-torque between the coupling bore and the shaft.

# SRB SERIES

## Radial Beam Coupling (Ultra High Strength Aluminum Alloy Body)

### Standard Inner Diameter (ID)

Model	Standard Inner Diameter ( $d_1, d_2$ ) (mm)																			
	2	3	4	5	6	6.35	8	9.525	10	11	12	14	15	16	18	19	20	22	24	25
SRB-8□	●	●																		
SRB-12□		●	●	●																
SRB-16□		●	●	●	●															
SRB-19□			●	●	●	●	●													
SRB-22□				●	●	●	●	●	●											
SRB-26□				●	●	●	●	●	●	●										
SRB□-32□							●	●	●	●	●	●	●							
SRB□-39□									●	●	●	●	●	●	●	●	●			
SRB□-49□										●	●	●	●	●	●	●	●	●		
SRB□-60□													●	●	●	●	●	●	●	●

- The recommended shaft tolerance is h7.
- Custom process (e.g. non-standard Inner diameter, special tolerance etc.) is also available upon a special request in prior to order placement.  
(※ Exception Item: SRB-8)
- Keyway is available. (Optional)

### Slip Torque

- The below table shows the actual permissible torque values when the slip torque value is lower than the coupling's max. torque value.
- If the slip torque value is lower than the coupling's max. torque value, please check and compare between the slip torque in the below table and the operating torque value of the connected motor. It is safer to size up the coupling or use a key/keyway when the slip torque value is lower than the motor's operating torque.
- The below slip torque values may be subject to change according to different testing conditions. (e.g. shaft tolerance, surface roughness, surface treatment or acceleration/deceleration of driving shafts). On the other hand, the values could be affected when a different kind of fastening screw is used (body material or surface treatment). Therefore, we recommend you test under the same conditions before mounting.

Model	Max. Torque (N.m)	Slip Torque (N.m) by Inner Diameter ( $d_1, d_2$ )													
		5	6	6.35	8	9.525	10	11	12	14	15	16	18	19	
SRB-26C	4	2.2	2.8	2.8	3.5										
SRB□-32C	7.6				5.6	7									
SRB□-39C	14						12								
SRB□-49C	30								21	27					
SRB□-60C	60											34	40	46	54

# SRB SERIES (SRBM)

Radial Beam Coupling (Ultra High Strength Aluminum Alloy Body)

## Set-screw (SRBM-no mark)

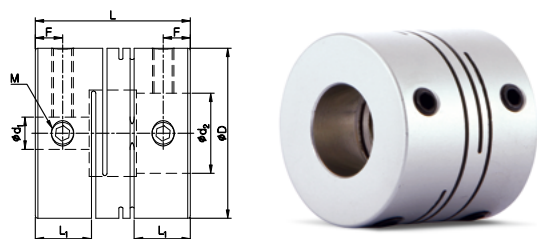

## Side-clamp (SRBM-C)

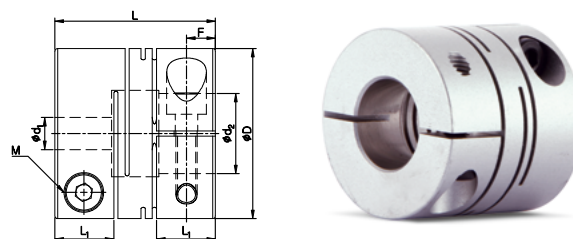

## Dimensions / Performance

### Set-screw

Model	Size ( $\pm 0.3\text{mm}$ )				Screw		Rated Torque (N·m)	Max. Torque (N·m)	Max. rpm ( $\text{min}^{-1}$ )	Moment of Inertia ( $\text{kg}\cdot\text{m}^2$ )	Static Torsional Stiffness (N·m/rad)	Mass (g)	Permissible Misalignment		
	D	L	L <sub>1</sub>	F	Size	Fastening Torque (N·m)							Angular (°)	Parallel (mm)	End-play (mm)
SRBM-12	12.7	13	4.5	2.2	M2.5	0.5	0.2	0.4	40,000	$8.0 \times 10^{-8}$	60	3.2	1	-	$\pm 0.15$
SRBM-16	16	14	5	2.4	M3	0.7	0.4	0.8	30,000	$2.2 \times 10^{-7}$	130	5.8	1	-	$\pm 0.15$
SRBM-19	19.1	17	6.3	3.1	M3	0.7	0.6	1.2	24,000	$5.3 \times 10^{-7}$	160	10	1	-	$\pm 0.15$
SRBM-22	22.2	19	6.9	3.3	M4	1.7	1	2	20,000	$1.1 \times 10^{-6}$	180	14	1	-	$\pm 0.15$
SRBM-26	26.2	22	7.9	3.8	M4	1.7	2	4	18,000	$2.5 \times 10^{-6}$	480	25	1	-	$\pm 0.15$
SRBM-32	31.8	29	10.5	5.1	M5	4	3.8	7.6	16,000	$6.9 \times 10^{-6}$	780	44.9	1	-	$\pm 0.15$

- The Moment of Inertia and Mass values are based on products with max. Inner diameter.
- Max. torque/rated torque is the value regarding to a coupling's self-durability and is not related to slip-torque between the coupling bore and the shaft.  
(Set-screw type is usually less durable than other clamping method, thus please consider it has a complementary option e.g. keyway along with.)

### Side-clamp

Model	Size ( $\pm 0.3\text{mm}$ )				Screw		Rated Torque (N·m)	Max. Torque (N·m)	Max. rpm ( $\text{min}^{-1}$ )	Moment of Inertia ( $\text{kg}\cdot\text{m}^2$ )	Static Torsional Stiffness (N·m/rad)	Mass (g)	Permissible Misalignment		
	D	L	L <sub>1</sub>	F	Size	Fastening Torque (N·m)							Angular (°)	Parallel (mm)	End-play (mm)
SRBM-12C	12.7	14	5	2.5	M2	0.5	0.2	0.4	35,000	$7.9 \times 10^{-8}$	60	3.2	1	-	$\pm 0.15$
SRBM-16C	16	16	6	3	M2.6	1	0.4	0.8	27,000	$2.3 \times 10^{-7}$	130	6.3	1	-	$\pm 0.15$
SRBM-19C	19.1	17	6.3	3.1	M2.6	1	0.6	1.2	20,000	$5.0 \times 10^{-7}$	160	9.2	1	-	$\pm 0.15$
SRBM-22C	22.2	20	7.4	3.7	M3	1.7	1	2	18,000	$1.1 \times 10^{-6}$	180	15	1	-	$\pm 0.15$
SRBM-26C	26.2	23	8.4	4.1	M3	1.7	2	4	17,000	$2.5 \times 10^{-6}$	480	25	1	-	$\pm 0.15$
SRBM-32C	31.8	30	11	5.4	M4	3.5	3.8	7.6	14,000	$6.8 \times 10^{-6}$	780	44	1	-	$\pm 0.15$

- The Moment of Inertia and Mass values are based on products with max. Inner diameter.
- Max. torque/rated torque is the value regarding to a coupling's self-durability and is not related to slip-torque between the coupling bore and the shaft.

# SRB SERIES (SRBM)

## Radial Beam Coupling (Ultra High Strength Aluminum Alloy Body)

### Standard Inner Diameter (ID)

Model	Standard Inner Diameter (d <sub>1</sub> , d <sub>2</sub> ) (mm)											
	3	4	5	6	6.35	8	9.525	10	11	12	14	15
SRBM-12□	●	●	●									
SRBM-16□	●	●	●	●								
SRBM-19□		●	●	●	●	●						
SRBM-22□			●	●	●	●	●	●				
SRBM-26□			●	●	●	●	●	●	●	●		
SRBM-32□						●	●	●	●	●	●	●

- The recommended shaft tolerance is h7.
- Custom process (e.g. non-standard Inner diameter, special tolerance etc.) is also available upon a special request in prior to order placement.
- Keyway is available. (Optional)

### Slip Torque (Side-clamp type only)

- The below table shows the actual permissible torque values when the slip torque value is lower than the coupling's max. torque value.
- If the slip torque value is lower than the coupling's max. torque value, please check and compare between the slip torque in the below table and the operating torque value of the connected motor. It is safer to size up the coupling or use a key/keyway when the slip torque value is lower than the motor's operating torque.
- The below slip torque values may be subject to change according to different testing conditions. (e.g. shaft tolerance, surface roughness, surface treatment or acceleration/deceleration of driving shafts). On the other hand, the values could be affected when a different kind of fastening screw is used (body material or surface treatment). Therefore, we recommend you test under the same conditions before mounting.

Model	Max. Torque (N.m)	Slip Torque (N.m) by Inner Diameter (d <sub>1</sub> , d <sub>2</sub> )											
		5	6	6.35	8	9.525	10	11	12	14	15	16	18
SRBM-26C	4	2.2	2.8	2.8	3.5								
SRBM-32C	7.6				5.6	7							

# SRBS SERIES



## Radial Beam Coupling (Stainless Steel Body)

### Structure and Material

#### General



Set-screw (SRBS-no mark)



Side-clamp (SRBS-C)

Structure	Material	Surface Treatment
Body	Stainless Steel	-
Screw	STS304	-

#### Space-saving



Side-clamp (SRBMS-C)

Structure	Material	Surface Treatment
Body	Stainless Steel	-
Screw	STS304	-

### Product Features & Application

- SRB series is one-piece metal coupling with no backlash and absorbs misalignment through its slit structures.
- SRBS series is made of stainless steel to enhance its corrosion resistance. (However, rust may still occur depending on usage and storage conditions.)

	SRBS	SRBMS
Backlash free (Precision)	☆	☆
High Torque (Durability)	△	△
Torsional Stiffness	○	○
Vibration Absorption	-	-
Misalignment Absorption	○	△
Corrosion resistance	☆	☆
Applicable Motors	Servo	○
	Stepping	○
	Encoder	○
	General	-

**Application :** UVW Stage, XY Stage, Part feeder, Encoder and applications which requires corrosion resistant couplings.

#### INNER-RELIEF AREA

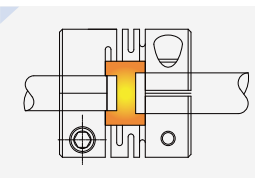

- SRB series has the “relief” space structure in the middle area, in case there is interference that causes damages.

#### ROUND-SHAPED SLITS

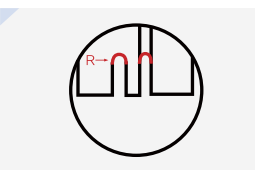

- SRB series has rounded slits(cuts) structure to disperse stress concentration.

### Clamping Methods

Set-screw (No mark)	General	○
	With Keyway	○
Side-clamp (C)	General	○
	Hub Split	X
	With Keyway	○
Taper-ring (T)		X

### How to Order

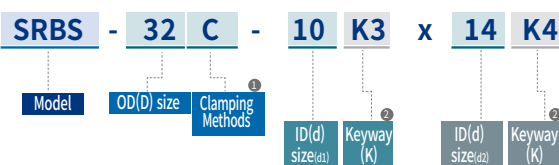

#### 1 Clamping Methods

- No mark Set-screw
- C General Side-clamp

#### 2 Keyway

- No mark No Keyway
- K(b size) Keyway processed according to the indicated b size.

# SRBS SERIES

## Radial Beam Coupling (Stainless Steel Body)

### Set-screw (SRBS-no mark)

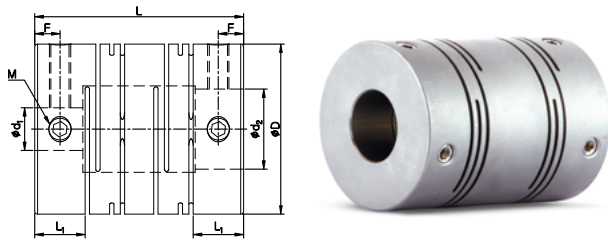

### Side-clamp (SRBS-C)

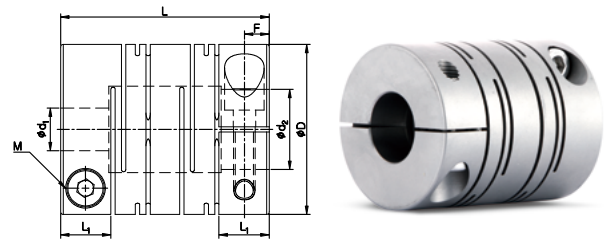

## Dimensions / Performance

### Set-screw

Model	Size ( $\pm 0.3\text{mm}$ , *L: $\pm 1.0\text{mm}$ )				Screw		Rated Torque (N·m)	Max. Torque (N·m)	Max. rpm ( $\text{min}^{-1}$ )	Moment of Inertia ( $\text{kg}\cdot\text{m}^2$ )	Static Torsional Stiffness (N·m/rad)	Mass (g)	Permissible Misalignment		
	D	L	L <sub>1</sub>	F	Size	Fastening Torque (N·m)							Angular (°)	Parallel (mm)	End-play (mm)
SRBS-12	12.7	18	4.5	2.2	M2.5	0.5	0.2	0.4	34,000	$3.0 \times 10^{-7}$	65	12.4	2.5	0.1	$\pm 0.3$
SRBS-16	16	18.5	4.7	2.3	M3	0.7	0.4	0.8	27,000	$7.7 \times 10^{-7}$	85	21	2.5	0.15	$\pm 0.3$
SRBS-19	19.1	22	5.9	2.9	M3	0.7	0.6	1.2	20,000	$1.8 \times 10^{-6}$	230	34	2.5	0.15	$\pm 0.3$
SRBS-22	22.2	25	6.5	3.2	M4	1.5	1	2	17,000	$3.8 \times 10^{-6}$	290	49.5	2.5	0.15	$\pm 0.4$
SRBS-26	26.2	30	7.7	3.4	M4	1.5	2	4	16,000	$8.8 \times 10^{-6}$	350	84	2.5	0.2	$\pm 0.4$
SRBS-32	31.8	39	9.4	4.7	M5	2	3.8	7.6	14,000	$2.7 \times 10^{-5}$	840	160	2.5	0.2	$\pm 0.4$
SRBS-39	39	56	16	5.9	M5	2	7	14	10,000	$8.8 \times 10^{-5}$	1,000	388	2.5	0.25	$\pm 0.4$
SRBS-49	49	70	19.8	9.4	M6	4	15	30	7,000	$2.8 \times 10^{-4}$	1,400	775	2.5	0.25	$\pm 0.5$
SRBS-60	60	88	19	9	M8	8	30	60	6,000	$7.6 \times 10^{-4}$	1,800	1,416	2.5	0.3	$\pm 0.5$

- The Moment of Inertia and Mass values are based on products with max. Inner diameter.
- Max. torque/rated torque is the value regarding to a coupling's self-durability and is not related to slip-torque between the coupling bore and the shaft. (Set-screw type is usually less durable than other clamping method, thus please consider it has a complementary option e.g. keyway along with.)

### Side-clamp

Model	Size ( $\pm 0.3\text{mm}$ , *L: $\pm 1.0\text{mm}$ )				Screw		Rated Torque (N·m)	Max. Torque (N·m)	Max. rpm ( $\text{min}^{-1}$ )	Moment of Inertia ( $\text{kg}\cdot\text{m}^2$ )	Static Torsional Stiffness (N·m/rad)	Mass (g)	Permissible Misalignment		
	D	L	L <sub>1</sub>	F	Size	Fastening Torque (N·m)							Angular (°)	Parallel (mm)	End-play (mm)
SRBS-12C	12.7	19	5	2.5	M2	0.5	0.2	0.4	32,000	$3.0 \times 10^{-7}$	65	13	2.5	0.1	$\pm 0.3$
SRBS-16C	16	21.5	6.1	3	M2.6	1	0.4	0.8	25,000	$9.0 \times 10^{-7}$	85	26	2.5	0.15	$\pm 0.3$
SRBS-19C	19.1	23	6.2	3.1	M2.6	1	0.6	1.2	18,000	$1.7 \times 10^{-6}$	230	32	2.5	0.15	$\pm 0.3$
SRBS-22C	22.2	26.5	7.2	3.6	M3	1.5	1	2	15,000	$3.8 \times 10^{-6}$	290	43	2.5	0.15	$\pm 0.4$
SRBS-26C	26.2	31.5	7.5	3.7	M3	1.5	2	4	14,000	$8.6 \times 10^{-6}$	350	84	2.5	0.2	$\pm 0.4$
SRBS-32C	31.8	39	9.4	4.7	M4	2.5	3.8	7.6	12,000	$2.5 \times 10^{-5}$	840	160	2.5	0.2	$\pm 0.4$
SRBAS-39C	39	43	10.7	5.3	M5	4	7	14	9,000	$6.1 \times 10^{-5}$	1,200	280	2.5	0.25	$\pm 0.4$
SRBBS-39C	39	56	12	5.5	M5	4	7	14	9,000	$8.6 \times 10^{-5}$	1,000	360	2.5	0.25	$\pm 0.4$
SRBAS-49C	49	63.5	15.1	7.5	M6	8	15	30	7,000	$2.7 \times 10^{-4}$	1,600	672	2.5	0.25	$\pm 0.5$
SRBBS-49C	49	70	14.5	7.2	M6	8	15	30	7,000	$2.8 \times 10^{-4}$	1,400	740	2.5	0.25	$\pm 0.5$
SRBAS-60C	60	76.2	19	9.4	M8	16	30	60	5,000	$7.2 \times 10^{-4}$	2,000	1,150	2.5	0.25	$\pm 0.5$
SRBBS-60C	60	88	19	9.4	M8	16	30	60	5,000	$8.6 \times 10^{-4}$	1,800	1,370	2.5	0.25	$\pm 0.5$

- The Moment of Inertia and Mass values are based on products with max. Inner diameter.
- Max. torque/rated torque is the value regarding to a coupling's self-durability and is not related to slip-torque between the coupling bore and the shaft.

# SRBS SERIES

## Radial Beam Coupling (Stainless Steel Body)

### Standard Inner Diameter (ID)

Model	Standard Inner Diameter (d <sub>1</sub> , d <sub>2</sub> ) (mm)																		
	3	4	5	6	6.35	8	9.525	10	11	12	14	15	16	18	19	20	22	24	25
SRBS-12□	●	●	●																
SRBS-16□	●	●	●	●															
SRBS-19□		●	●	●	●	●													
SRBS-22□			●	●	●	●	●	●											
SRBS-26□			●	●	●	●	●	●	●	●									
SRBS-32□						●	●	●	●	●	●	●							
SRB□S-39□								●	●	●	●	●	●	●	●				
SRB□S-49□										●	●	●	●	●	●	●			
SRB□S-60□												●	●	●	●	●	●	●	●

- The recommended shaft tolerance is h7.
- Custom process (e.g. non-standard Inner diameter, special tolerance etc.) is also available upon a special request in prior to order placement.
- Keyway is available. (Optional)

### Slip Torque

- The below table shows the actual permissible torque values when the slip torque value is lower than the coupling's max. torque value.
- If the slip torque value is lower than the coupling's max. torque value, please check and compare between the slip torque in the below table and the operating torque value of the connected motor. It is safer to size up the coupling or use a key/keyway when the slip torque value is lower than the motor's operating torque.
- The below slip torque values may be subject to change according to different testing conditions. (e.g. shaft tolerance, surface roughness, surface treatment or acceleration/deceleration of driving shafts). On the other hand, the values could be affected when a different kind of fastening screw is used (body material or surface treatment). Therefore, we recommend you test under the same conditions before mounting.

Model	Max. Torque (N.m)	Slip Torque (N.m) by Inner Diameter (d <sub>1</sub> , d <sub>2</sub> )																		
		3	4	5	6	6.35	8	9.525	10	11	12	14	15	16	18	19	20	22	24	25
SRBS-12C	0.4	0.3	0.5																	
SRBS-16C	0.8	0.7	0.9																	
SRBS-19C	1.2		0.9																	
SRBS-22C	2			1.4	1.8															
SRBS-26C	4			0.7	1	1.1	1.2	2	3.2	3.2	3.2									
SRBS-32C	7.6						1.4	1.4	1.4	1.7	3	4.1	3							
SRB□S-39C	14								2	2.3	2.7	4.4								
SRB□S-49C	30										5.1	6	6	7.4	8	9	12			
SRB□S-60C	60												7.7	15	17	17	17	19	45	40

# SRBS SERIES (SRBMS)

## Radial Beam Coupling (Stainless Steel Body)

### Side-clamp (SRBMS-C)

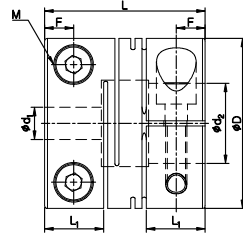

### Dimensions / Performance

Model	Size ( $\pm 0.3\text{mm}$ , *L: $\pm 1.0\text{mm}$ )				Screw		Rated Torque (N·m)	Max. Torque (N·m)	Max. rpm (min <sup>-1</sup> )	Moment of Inertia (kg·m <sup>2</sup> )	Static Torsional Stiffness (N·m/rad)	Mass (g)	Permissible Misalignment		
	D	L	L <sub>1</sub>	F	Size	Fastening Torque (N·m)							Angular (°)	Parallel (mm)	End-play (mm)
SRBMS-12C	12.7	14	5	2.5	M2	0.5	0.2	0.4	20,000	$2.4 \times 10^{-7}$	120	10	1	-	$\pm 0.15$
SRBMS-16C	16	16	6	3	M2.6	1	0.4	0.8	20,000	$7.0 \times 10^{-7}$	240	20	1	-	$\pm 0.15$
SRBMS-19C	19.1	17	6.3	3.1	M2.6	1	0.6	1.2	19,000	$1.5 \times 10^{-6}$	300	32	1	-	$\pm 0.15$
SRBMS-22C	22.2	20	7.4	3.7	M3	1.5	1	2	17,000	$3.1 \times 10^{-6}$	350	42	1	-	$\pm 0.15$
SRBMS-26C	26.2	23	8.4	4.1	M3	1.5	2	4	15,000	$7.2 \times 10^{-6}$	720	70	1	-	$\pm 0.15$
SRBMS-32C	31.8	30	11	5.4	M4	2.5	3.8	7.6	10,000	$2.0 \times 10^{-5}$	1,300	140	1	-	$\pm 0.15$

- The Moment of Inertia and Mass values are based on products with max. Inner diameter.
- Max. torque/rated torque is the value regarding to a coupling's self-durability and is not related to slip-torque between the coupling bore and the shaft.

### Standard Inner Diameter (ID)

Model	Standard Inner Diameter (d <sub>1</sub> , d <sub>2</sub> ) (mm)											
	3	4	5	6	6.35	8	9.525	10	11	12	14	15
SRBMS-12C	●	●	●									
SRBMS-16C	●	●	●	●								
SRBMS-19C		●	●	●	●	●						
SRBMS-22C			●	●	●	●	●	●				
SRBMS-26C			●	●	●	●	●	●	●	●		
SRBMS-32C						●	●	●	●	●	●	●

- The recommended shaft tolerance is h7.
- Custom process (e.g. non-standard Inner diameter, special tolerance etc.) is also available upon a special request in prior to order placement.
- Keyway is available. (Optional)

### Slip Torque

- The below table shows the actual permissible torque values when the slip torque value is lower than the coupling's max. torque value.
- If the slip torque value is lower than the coupling's max. torque value, please check and compare between the slip torque in the below table and the operating torque value of the connected motor. It is safer to size up the coupling or use a key/keyway when the slip torque value is lower than the motor's operating torque.
- The below slip torque values may be subject to change according to different testing conditions. (e.g. shaft tolerance, surface roughness, surface treatment or acceleration/deceleration of driving shafts). On the other hand, the values could be affected when a different kind of fastening screw is used (body material or surface treatment). Therefore, we recommend you test under the same conditions before mounting.

Model	Max. Torque (N·m)	Slip Torque (N·m) by Inner Diameter (d <sub>1</sub> , d <sub>2</sub> )											
		3	4	5	6	6.35	8	9.525	10	11	12	14	15
SRBMS-12C	0.4	0.3	0.3	0.3									
SRBMS-16C	0.8	0.4	0.5										
SRBMS-19C	1.2		0.7	1.1									
SRBMS-22C	2			1	1.3	1.4	1.8						
SRBMS-26C	4			1.3	1.3	1.6	2.2	2	2	2.3			
SRBMS-32C	7.6						1.5	1.5	1.5	1.7	2.9	4.1	3.5

# SRG SERIES



## Rigid Coupling

### Structure and Material

#### Set-screw



SRG-no mark

Structure	Material	Surface Treatment
Body	High Strength Aluminum Alloy	Anodizing
Screw	SCM435	Black Oxide

#### Side-clamp



SRG-C



SRGL-C

Structure	Material	Surface Treatment
Body	High Strength Aluminum Alloy	Anodizing
Screw	SCM435	Black Oxide

### Product Features & Application

- SRG Series is one-piece metal coupling with no backlash and it doesn't allow any loss of motion while transmitting.
- Because this series doesn't absorb misalignment, the allocation of shafts should be set-up in line accurately without any misalignment.

Backlash free (Precision)	☆
High Torque (Durability)	○
Torsional Stiffness	☆
Vibration Absorption	-
Misalignment Absorption	-

Applicable Motors	Servo	○
	Stepping	○
	Encoder	-
	General	-

### Clamping Methods

Set-screw (No mark)	General	○
	With Keyway	○
Side-clamp (C)	General	○
	Hub Split	○
	With Keyway	○
Taper-ring (T)		X

### How to Order

**SRGL - 53 CW - 20 W K6 x 20 W K6**

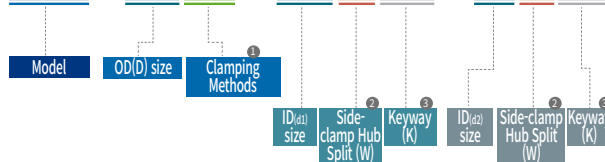

1 Clamping Methods	No mark	Set-screw		
	C	General Side-clamp		
	CW	Side-clamp Hub Split		
2 Side-clamp Hub Split	No mark	Keyway		
		Not Split	No mark	No Keyway
	W	Split	K(b size)	Keyway processed according to the indicated b size.

# SRG SERIES

## Rigid Coupling

### Set-screw

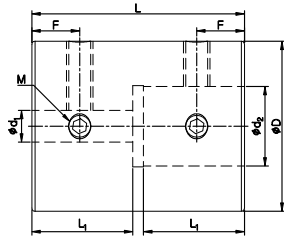

#### Dimensions / Performance

Model	Size ( $\pm 0.3\text{mm}$ )				Screw		Rated Torque (N·m)	Max. rpm (min <sup>-1</sup> )	Moment of Inertia (kg·m <sup>2</sup> )	Mass (g)
	D	L	L <sub>1</sub>	F	Size	Fastening Torque (N·m)				
SRG-16	16	22.5	10.3	5	M3	0.7	1	25,000	$3.9 \times 10^{-7}$	10
SRG-20	20	24	11	5.5	M3	0.7	2.5	20,000	$9.7 \times 10^{-7}$	15.4
SRG-25	25	35	16.5	7.5	M4	1.7	4	18,000	$3.5 \times 10^{-6}$	36
SRG-32	32	40	19	9	M5	4	9	14,000	$1.1 \times 10^{-5}$	69
SRG-43	43	52	25	12	M6	7	20	12,000	$4.6 \times 10^{-5}$	153
SRG-53	53	66	32	15.5	M8	15	25	8,000	$1.4 \times 10^{-4}$	316

- The Moment of Inertia and Mass values are based on products with max. Inner diameter.
- Max. torque/rated torque is the value regarding to a coupling's self-durability and is not related to slip-torque between the coupling bore and the shaft. (Set-screw type is usually less durable than other clamping method, thus please consider it has a complementary option e.g. keyway along with.)

#### Standard Inner Diameter (ID)

Model	Standard Inner Diameter (d <sub>1</sub> , d <sub>2</sub> ) (mm)														
	3	4	5	6	8	10	11	12	14	15	16	18	20	22	24
SRG-16	●	●	●	●											
SRG-20		●	●	●	●	●									
SRG-25			●	●	●	●	●	●							
SRG-32				●	●	●	●	●	●	●					
SRG-43						●	●	●	●	●	●	●	●	●	●
SRG-53								●	●	●	●	●	●	●	●

- The recommended shaft tolerance is h7.
- Custom process (e.g. non-standard Inner diameter, special tolerance etc.) is also available upon a special request in prior to order placement.
- Keyway is available. (Optional)

# SRG SERIES

## Rigid Coupling

### Side-clamp

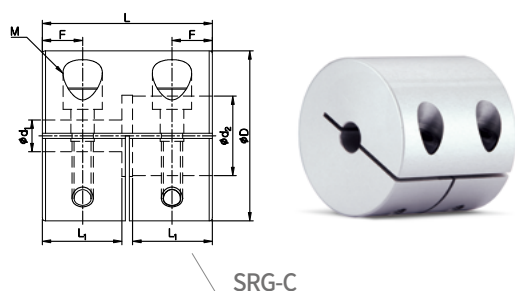

SRG-C

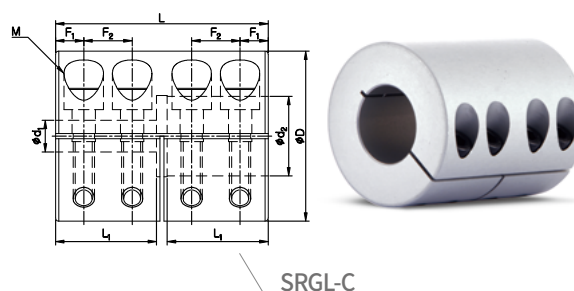

SRGL-C

### Dimensions / Performance

#### SRG-C

Model	Size ( $\pm 0.3\text{mm}$ )				Screw		Rated Torque (N·m)	Max. rpm ( $\text{min}^{-1}$ )	Moment of Inertia ( $\text{kg}\cdot\text{m}^2$ )	Mass (g)	Side-clamp Hub Split (W)
	D	L	L <sub>1</sub>	F	Size	Fastening Torque (N·m)					
SRG-16C	16	16	7	3.7	M2.6	1	1	18,000	$2.5 \times 10^{-7}$	6.8	○
SRG-20C	20	20	9	4.6	M2.6	1	2.5	15,000	$7.5 \times 10^{-7}$	12	○
SRG-25C	25	25	11.5	5.8	M3	1.7	4	12,000	$2.3 \times 10^{-6}$	24	○
SRG-32C	32	32	15	7.6	M4	3.5	9	10,000	$8.0 \times 10^{-6}$	52	○
SRG-43C	43	41	19.5	10	M5	8	20	8,000	$3.3 \times 10^{-5}$	114	○
SRG-53C	53	51	24.5	12.5	M6	13	25	6,000	$9.2 \times 10^{-5}$	234	○

- The Moment of Inertia and Mass values are based on products with max. Inner diameter.
- Max. torque/rated torque is the value regarding to a coupling's self-durability and is not related to slip-torque between the coupling bore and the shaft.

#### SRGL-C

Model	Size ( $\pm 0.3\text{mm}$ )					Screw		Rated Torque (N·m)	Max. rpm ( $\text{min}^{-1}$ )	Moment of Inertia ( $\text{kg}\cdot\text{m}^2$ )	Mass (g)	Side-clamp Hub Split (W)
	D	L	L <sub>1</sub>	F <sub>1</sub>	F <sub>2</sub>	Size	Fastening Torque (N·m)					
SRGL-16C	16	22.5	10.3	3	5.4	M2.6	1	1	16,000	$3.4 \times 10^{-7}$	9.3	○
SRGL-20C	20	24	11	3.1	5.6	M2.6	1	2.5	14,000	$8.6 \times 10^{-7}$	14	○
SRGL-25C	25	35	16.5	4.7	7.6	M3	1.7	4	10,000	$3.2 \times 10^{-6}$	34	○
SRGL-32C	32	40	19	5.3	9.1	M4	3.5	9	9,000	$9.8 \times 10^{-6}$	63	○
SRGL-43C	43	52	25	7	11.5	M5	8	20	7,000	$4.1 \times 10^{-5}$	141	○
SRGL-53C	53	66	32	9	14.5	M6	13	25	5,500	$1.3 \times 10^{-4}$	297	○

- The Moment of Inertia and Mass values are based on products with max. Inner diameter.
- Max. torque/rated torque is the value regarding to a coupling's self-durability and is not related to slip-torque between the coupling bore and the shaft.
- To ensure even tightening, tighten the screws to the recommended torque for the initial tightening, and then repeat the process 2-3 times, alternating with each screw.

### Standard Inner Diameter (ID)

Model	Standard Inner Diameter ( $d_1, d_2$ ) (mm)														
	3	4	5	6	8	10	11	12	14	15	16	18	20	22	24
SRG□-16C	●	●	●	●											
SRG□-20C		●	●	●	●	●									
SRG□-25C			●	●	●	●	●	●							
SRG□-32C				●	●	●	●	●	●	●					
SRG□-43C						●	●	●	●	●	●	●	●	●	●
SRG□-53C								●	●	●	●	●	●	●	●

- The recommended shaft tolerance is h7.
- Custom process (e.g. non-standard inner diameter, special tolerance etc.) is also available upon a special request in prior to order placement.
- Keyway is available. (Optional)

# SRG SERIES

## Rigid Coupling

### Slip Torque

- The below table shows the actual permissible torque values when the slip torque value is lower than the coupling's max. torque value.
- If the slip torque value is lower than the coupling's max. torque value, please check and compare between the slip torque in the below table and the operating torque value of the connected motor. It is safer to size up the coupling or use a key/keyway when the slip torque value is lower than the motor's operating torque.
- The below slip torque values may be subject to change according to different testing conditions. (e.g. shaft tolerance, surface roughness, surface treatment or acceleration/deceleration of driving shafts). On the other hand, the values could be affected when a different kind of fastening screw is used (body material or surface treatment). Therefore, we recommend you test under the same conditions before mounting.

Model	Rated Torque (N.m)	Slip Torque (N.m) by Inner Diameter (d <sub>1</sub> , d <sub>2</sub> )								
		3	4	5	6	8	10	11	12	14
SRG□-16C	1	1								
SRG□-20C	2.5		1.7							
SRG□-25C	4									
SRG□-32C	9				7.5	8.5				
SRG□-43C	20									
SRG□-53C	25									

### Various options for Side-clamp Hub Split available

<p>SRG-C 1-side hub split</p>  <p>SRG-32CW-10W-14</p> <p>ID 10mm : Hub Split (W) ID 14mm : Not Split</p> 	<p>SRG-C Both-sides hub split</p>  <p>SRG-32CW-10W-14W</p> <p>ID 10mm : Hub Split (W) ID 14mm : Hub Split (W)</p> 	<p>SRGL-C 1-side hub split</p>  <p>SRGL-32CW-10W-14</p> <p>ID 10mm : Hub Split (W) ID 14mm : Not Split</p> 	<p>SRGL-C Both-sides hub split</p>  <p>SRGL-32CW-10W-14W</p> <p>ID 10mm : Hub Split (W) ID 14mm : Hub Split (W)</p> 
---	--	---	--

# SRGS SERIES



## Rigid Coupling(Stainless Steel Body)



### Structure and Material

#### Set-screw



SRGS-no mark

Structure	Material
Body	Stainless Steel
Screw	STS304

#### Side-Clamp



SRGS-C

Structure	Material
Body	Stainless Steel
Screw	STS304

### Product Features & Application

- SRG Series is one-piece metal coupling with no backlash and it doesn't allow any loss of motion while transmitting.
- Because this series doesn't absorb misalignment, the allocation of shafts should be set-up in line accurately without any misalignment.
- SRGS Series is an enhanced version in terms of corrosion resistance by adopting stainless steel as its material.

Backlash free (Precision)	☆
Torsional Stiffness	☆
Vibration Absorption	-
Misalignment Absorption	-
Corrosion Resistance	☆

Applicable Motors	Servo	○
	Stepping	○
	Encoder	-
	General	-

### Clamping Methods

Set-screw (No mark)	General	○
	With Keyway	○
Side-clamp (C)	General	○
	Hub Split	○
	With Keyway	○
Taper-ring (T)		X

### How to Order

**SRGS - 32 CW - 10 W K3 x 10 W K3**

**1 Clamping Methods**

No mark	Set-screw
C	General Side-clamp
CW	Side-clamp Hub Split

**2 Side-clamp Hub Split**

No mark	Not Split	Keyway	No mark	No Keyway
W	Split	K(b size)	Keyway processed according to the indicated b size.	

# SRGS SERIES



## Rigid Coupling(Stainless Steel Body)

### Set-screw

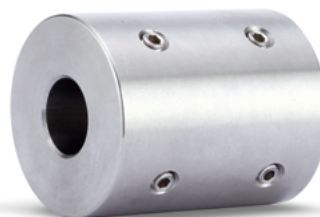
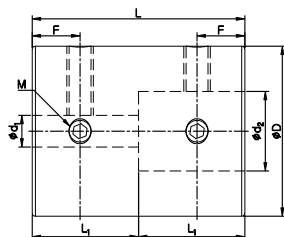

### Dimensions / Performance

Model	Size ( $\pm 0.3\text{mm}$ )			Screw		Rated Torque (N·m)	Max. rpm ( $\text{min}^{-1}$ )	Moment of Inertia ( $\text{kg}\cdot\text{m}^2$ )	Mass (g)
	D	L	F	Size	Fastening Torque (N·m)				
SRGS-16	16	24	6	M3	0.7	0.3	23,000	$1.2 \times 10^{-6}$	28
SRGS-20	20	30	7	M3	0.7	0.5	18,000	$3.5 \times 10^{-6}$	54
SRGS-25	25	36	9	M4	1.5	1	15,000	$1.0 \times 10^{-5}$	100
SRGS-32	32	41	10	M4	1.5	2	12,000	$3.1 \times 10^{-5}$	190

- The Moment of Inertia and Mass values are based on products with max. Inner diameter.
- Max. torque/rated torque is the value regarding to a coupling's self-durability and is not related to slip-torque between the coupling bore and the shaft. (Set-screw type is usually less durable than other clamping method, thus please consider it has a complementary option e.g. keyway along with.)

### Standard Inner Diameter (ID)

Model	Standard Inner Diameter ( $d_1, d_2$ ) (mm)									
SRGS-16	3-3	3-4	3-5	3-6	4-4	4-5	4-6	5-5	5-6	6-6
SRGS-20	5-5	5-6	5-8	5-10	6-6	6-8	6-10	8-8	8-10	10-10
SRGS-25	8-8	8-10	8-11	8-12	10-10	10-11	10-12	11-11	11-12	12-12
SRGS-32	12-12	12-14	12-15	12-16	14-14	14-15	14-16	15-15	15-16	16-16

- The recommended shaft tolerance is h7.
- Custom process (e.g. non-standard Inner diameter, special tolerance etc.) is also available upon a special request in prior to order placement.
- Keyway is available. (Optional)

# SRGS SERIES

## Rigid Coupling(Stainless Steel Body)

### Side-clamp

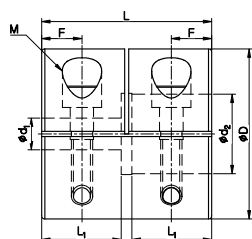

### Dimensions / Performance

Model	Size (±0.3mm)				Screw		Rated Torque (N·m)	Max. rpm (min <sup>-1</sup> )	Moment of Inertia (kg·m <sup>2</sup> )	Mass (g)	Side-clamp Hub Split (W)
	D	L	L <sub>1</sub>	F	Size	Fastening Torque (N·m)					
SRGS-16C	16	16	7	3.8	M2.5	1	0.3	15,000	8.0×10 <sup>-7</sup>	22	○
SRGS-20C	20	20	9	4.8	M2.5	1	0.5	13,000	2.4×10 <sup>-6</sup>	41	○
SRGS-25C	25	25	11.5	6	M3	1.5	1	10,000	7.3×10 <sup>-6</sup>	80	○
SRGS-32C	32	32	15	7.8	M4	2.5	2	7,000	2.5×10 <sup>-5</sup>	160	○

- The Moment of Inertia and Mass values are based on products with max. Inner diameter.
- Max. torque/rated torque is the value regarding to a coupling's self-durability and is not related to slip-torque between the coupling bore and the shaft.

### Standard Inner Diameter (ID)

Model	Standard Inner Diameter (d <sub>1</sub> , d <sub>2</sub> ) (mm)					
SRGS-16C	5-5	5-6	6-6			
SRGS-20C	6-6	6-8	8-8			
SRGS-25C	8-8	8-10	10-10			
SRGS-32C	10-10	10-12	10-14	12-12	12-14	14-14

- The recommended shaft tolerance is h7.
- Custom process (e.g. non-standard Inner diameter, special tolerance etc.) is also available upon a special request in prior to order placement.
- Keyway is available. (Optional)

### Various options for Side-clamp Hub Split available

SRGS-C 1-side hub split



SRGS-32CW-10W-14

ID 10mm : Hub Split (W)

ID 14mm : Not Split



SRGS-C Both-sides hub split

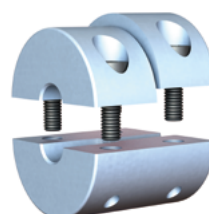

SRGS-32CW-10W-14W

ID 10mm : Hub Split (W)

ID 14mm : Hub Split (W)



# SRGP SERIES



## Ultra High Stiffness Rigid Coupling (Steel Body)



### Structure and Material

Structure	Material	Surface Treatment
Body	S45C (Quenching & Tempering)	Black Oxide
Cover	S45C (Quenching & Tempering)	Black Oxide
Screw	SCM435	Black Oxide

※ If another surface treatment is required, please ask our customer service team.

### Product Features & Application

Backlash free (Precision)	☆
High Torque (Durability)	☆
Torsional Stiffness	☆☆
Vibration Absorption	-
Misalignment Absorption	-

- SRG Series is one-piece metal coupling with no backlash and it doesn't allow any loss of motion while transmitting.
- Because this series doesn't absorb misalignment, the allocation of shafts should be set-up in line accurately without any misalignment.
- Excellent for balancing with the perfect symmetry for the rotating shafts.
- By processing inner and outer diameter simultaneously, it enables users to install the coupling in a more precise way.

### Clamping Methods

Set-screw (No mark)	General	X
	With Keyway	X
Side-clamp (C)	General	X
	Hub Split	X
	With Keyway	X
Taper-ring (T)		○

### How to Order

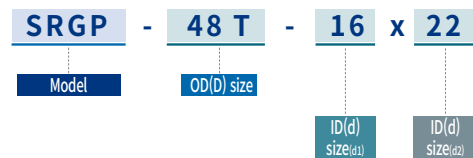

### HOW TO INSTALL

- Remove dust from the surface and spread oil thinly where inner bore and the inserting shaft face each other. (Any oil type which includes molybdenum-sulfur compounds or silicone is prohibited.)
- Insert the shaft up to the recommended depth of the hub.
- Place a dial gauge right on the surface which is machined with the inner diameter simultaneously (see figure) and rotate the shaft. Fasten the screws with 1/8 of fastening torque and adjust until the gauge variation (run-out) is zero. It is highly recommended to use a torque wrench in order to fasten them with the same torque.
- Increase the fastening torque gradually (first 1/4 and then 1/2 of fastening torque) in sequential order as shown on the right-hand figure.
- Fasten the screws with full of fastening torque until the screws are firmly placed. Check the values on the dial gauge (run-out) by rotating the shaft slowly.
- Insert the opposite shaft and fasten screws according to the above instruction.

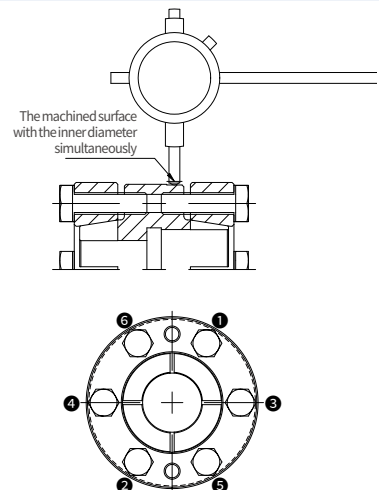

# SRGP SERIES

## Ultra High Stiffness Rigid Coupling (Steel Body)

### Taper-ring

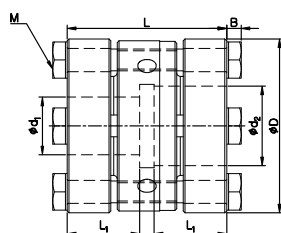

### Dimensions / Performance

Model	Size ( $\pm 0.3\text{mm}$ )				Screw		Max. rpm ( $\text{min}^{-1}$ )	Moment of Inertia ( $\text{kg}\cdot\text{m}^2$ )	Mass (g)	ID Range	Rated Torque (N·m)
	D	L	L <sub>1</sub>	B	Size	Fastening Torque (N·m)					
SRGP-48T	48	44	20	4	M6	14	15,000	$0.16 \times 10^{-3}$	460	16~22	90 ~ 140
SRGP-54T	54	52	24	4	M6	14	13,000	$0.29 \times 10^{-3}$	680	18~25	80 ~ 190
SRGP-64T	64	52	24	4	M6	14	12,000	$0.56 \times 10^{-3}$	860	22~35	150 ~ 460
SRGP-78T	78	55	25.5	4	M6	14	9,500	$1.23 \times 10^{-3}$	1,190	30~48	180 ~ 490

- The Moment of Inertia and Mass values are based on products with max. Inner diameter.
- The permissible torque is determined by its inner diameter size. Please refer to the bottom of the page for more details.
- Due to the structure of Taper-ring, it's not allowed to have other complementary options (e.g. keyway etc.) to enhance clamping force.

### Standard Inner Diameter (ID)

Model	Standard Inner Diameter ( $d_1, d_2$ ) (mm)															
	16	18	19	20	22	24	25	25.4	28	30	32	35	40	42	45	48
SRGP-48T	●	●	●	●	●											
SRGP-54T		●	●	●	●	●	●									
SRGP-64T				●	●	●	●	●	●	●	●	●				
SRGP-78T										●	●	●	●	●	●	●

- The recommended shaft tolerance is h7.
- Custom process (e.g. non-standard Inner diameter, special tolerance etc.) is also available upon a special request in prior to order placement.

### Slip Torque

- The below table shows the actual permissible torque values when the slip torque value is lower than the coupling's max. torque value.
- The below slip torque values may be subject to change according to different testing conditions. (e.g. shaft tolerance, surface roughness, surface treatment or acceleration/deceleration of driving shafts). On the other hand, the values could be affected when different kind of fastening screw is used. Therefore, we recommend you test under the same conditions before mounting.
- The permissible torque of a complete SRGP coupling should be considered according to the smaller inner diameter's value.

Model	Slip Torque (N·m) by Inner Diameter ( $d_1, d_2$ )															
	16	18	19	20	22	24	25	25.4	28	30	32	35	40	42	45	48
SRGP-48T	90	110	120	130	140											
SRGP-54T		80	100	110	145	180	190									
SRGP-64T					150	200	220	220	290	340	390	460				
SRGP-78T										180	220	270	360	390	440	490

# SCJ SERIES



## Cross Joint Coupling

### Structure and Material



Structure	Material	Surface Treatment
Hub	High Strength Aluminum Alloy	Anodizing
Center Block	Stainless Steel	-
Pin	SUJ2	Electroless Nickel Plating
Bushing	DU Bearing	-
Screw	SCM435	Black Oxide

### Product Features & Application

- SCJ series is excellent for absorbing both angular/parallel misalignment through middle pin/bushing structure and minimizes reaction force on the shaft. (This coupling combines strong features of SOH series coupling and universal joint.)
- This series structurally doesn't absorb end-play.

High Torque (Durability)		△
Torsional Stiffness		○
Vibration Absorption		△
Misalignment Absorption		☆
Minimized Reaction Force		☆
Applicable Motors	Servo	○
	Stepping	○
	Encoder	○
	General	-

**Application :** Cartesian Robot, UVW Stage, Machine tools, Index Table

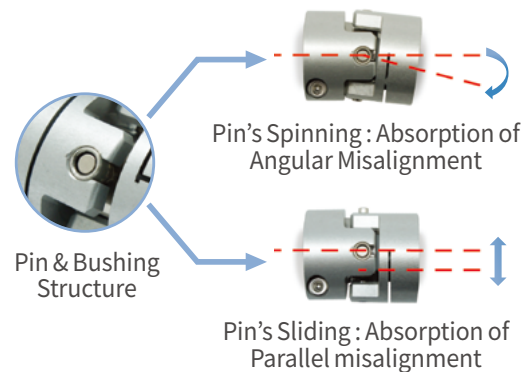

### Clamping Methods

Set-screw (No mark)	General	○
	With Keyway	○
Side-clamp (C)	General	○
	Hub Split	X
	With Keyway	○
Taper-ring (T)		X

### How to Order

**SCJA - 32 C - 10 K3 x 14 K4**

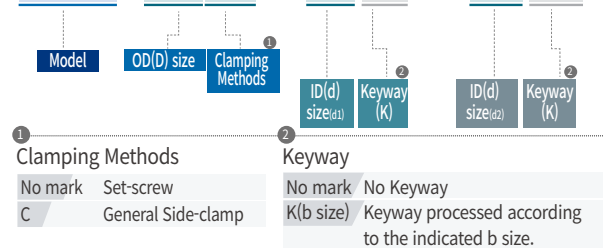

# SCJ SERIES

## Cross Joint Coupling

### Set-screw

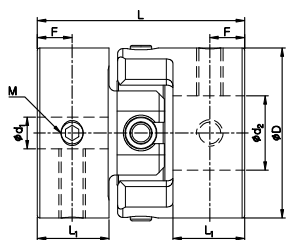

### Dimensions / Performance

Model	Size ( $\pm 0.3\text{mm}$ )				Screw		Rated Torque (N·m)	Max. Torque (N·m)	Max. rpm ( $\text{min}^{-1}$ )	Moment of Inertia ( $\text{kg}\cdot\text{m}^2$ )	Static Torsional Stiffness (N·m/rad)	Mass (g)	Permissible Misalignment	
	D	L	L <sub>1</sub>	F	Size	Fastening Torque (N·m)							Angular (°)	Parallel (mm)
SCJ-15	15	22.2	8	3.9	M3	0.7	0.25	0.5	21,000	$2.9 \times 10^{-7}$	200	9	1.5	0.3
SCJ-20	20	23.4	7.9	3.8	M3	0.7	0.5	1	16,000	$1.0 \times 10^{-6}$	450	20	1.5	0.5
SCJ-25	25	30.4	10.4	5	M4	1.7	1	2	12,000	$3.1 \times 10^{-6}$	800	35	1.5	0.5
SCJ-32	32	39	13.5	6.6	M4	1.7	2	4	9,000	$1.1 \times 10^{-5}$	1,200	75	1.5	0.5
SCJ-40	40	45.6	16	7.8	M5	4	5	10	7,000	$3.1 \times 10^{-5}$	1,900	145	1.5	0.5

- The Moment of Inertia and Mass values are based on products with max. Inner diameter.
- Max. torque/rated torque is the value regarding to a coupling's self-durability and is not related to slip-torque between the coupling bore and the shaft. (Set-screw type is usually less durable than other clamping method, thus please consider it has a complementary option e.g. keyway along with.)

### Standard Inner Diameter (ID)

Model	Standard Inner Diameter ( $d_1, d_2$ ) (mm)											
	3	4	5	6	6.35	8	10	11	12	14	15	
SCJ-15	●	●	●									
SCJ-20		●	●	●	●	●						
SCJ-25			●	●	●	●	●					
SCJ-32				●	●	●	●	●	●	●		
SCJ-40						●	●	●	●	●	●	

- The recommended shaft tolerance is h7.
- Custom process (e.g. non-standard Inner diameter, special tolerance etc.) is also available upon a special request in prior to order placement.
- Keyway is available. (Optional)

# SCJ SERIES

## Cross Joint Coupling

### Side-clamp

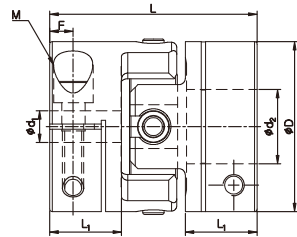

### Dimensions / Performance

Model	Size ( $\pm 0.3\text{mm}$ )				Screw		Rated Torque (N·m)	Max. Torque (N·m)	Max. rpm ( $\text{min}^{-1}$ )	Moment of Inertia ( $\text{kg}\cdot\text{m}^2$ )	Static Torsional Stiffness (N·m/rad)	Mass (g)	Permissible Misalignment	
	D	L	L <sub>1</sub>	F	Size	Fastening Torque (N·m)							Angular (°)	Parallel (mm)
SCJA-15C	15	22.2	8	3	M2.6	1	0.25	0.5	21,000	$3.3 \times 10^{-7}$	220	9	1.5	0.3
SCJB-15C	15	24.2	8	3	M2.6	1	0.25	0.5	18,000	$3.5 \times 10^{-7}$	200	10	2	0.3
SCJA-20C	20	23.4	7.9	2.8	M2.6	1	0.5	1	16,000	$1.2 \times 10^{-6}$	350	19	1.5	0.5
SCJB-20C	20	26.4	7.9	2.8	M2.6	1	0.5	1	12,000	$1.3 \times 10^{-6}$	300	20	2	0.5
SCJA-25C	25	30.4	10.4	3.6	M3	1.7	1	2	12,000	$3.3 \times 10^{-6}$	800	34	1.5	0.5
SCJB-25C	25	33.4	10.4	3.6	M3	1.7	1	2	9,000	$3.4 \times 10^{-6}$	700	35	2	0.5
SCJA-32C	32	39	13.5	4.4	M4	3.5	2	4	9,000	$1.1 \times 10^{-5}$	1,200	72	1.5	0.5
SCJB-32C	32	43	13.5	4.4	M4	3.5	2	4	7,000	$1.2 \times 10^{-5}$	1,000	75	2	0.5
SCJA-40C	40	45.6	16	5.9	M5	8	5	10	7,000	$3.2 \times 10^{-5}$	1,900	140	1.5	0.5
SCJB-40C	40	51	16	5.9	M5	8	5	10	5,000	$3.3 \times 10^{-5}$	1,800	145	2	0.5

- The Moment of Inertia and Mass values are based on products with max. Inner diameter.
- Max. torque/rated torque is the value regarding to a coupling's self-durability and is not related to slip-torque between the coupling bore and the shaft.

### Standard Inner Diameter (ID)

Model	Standard Inner Diameter ( $d_1, d_2$ ) (mm)										
	3	4	5	6	6.35	8	10	11	12	14	15
SCJ□-15C	●	●	●								
SCJ□-20C		●	●	●	●	●					
SCJ□-25C			●	●	●	●	●				
SCJ□-32C				●	●	●	●	●	●	●	
SCJ□-40C						●	●	●	●	●	●

- The recommended shaft tolerance is h7.
- Custom process (e.g. non-standard Inner diameter, special tolerance etc.) is also available upon a special request in prior to order placement.
- Keyway is available. (Optional)

# SFC SERIES



## Urethane Flexible Coupling



### Structure and Material

Structure	Material	Surface Treatment
Hub	Steel	Nickel Plating
Middle Part	Poly Urethane	-
Screws	SCM435	Black Oxide

### Product Features & Application

- SFC series is flexible with Urethane material and is especially excellent for absorbing misalignment to a greater extent.
- The middle Urethane structure absorbs external impacts and absorbs vibration.

Vibration Absorption	<input type="radio"/>	Applicable Motors	Servo	-
Misalignment Absorption	<input type="radio"/>		Stepping	-
Insulation of Electric Current	<input type="radio"/>		Encoder	<input type="radio"/>
			General	<input type="radio"/>

### Clamping Methods

Set-screw (No mark)	General	<input type="radio"/>
	With Keyway	X
Side-clamp (C)	General	X
	Hub Split	X
	With Keyway	X
Taper-ring (T)		X

### How to Order

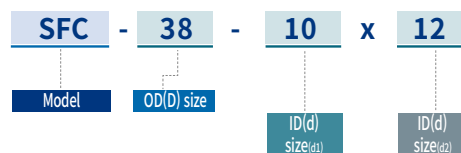

# SFC SERIES

## Urethane Flexible Coupling

### Set-screw

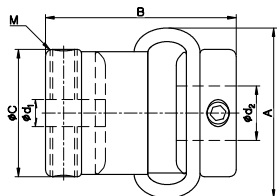

Size: 29, 38

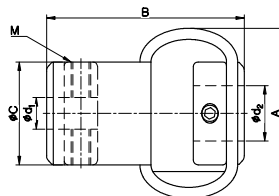

Size: 48, 54

### Dimensions / Performance

Model	Size (±0.3mm)			Screw		Max. Torque (N·m)	Max. rpm (min <sup>-1</sup> )	Mass (g)	Permissible Misalignment		
	A	B	C	Size	Fastening Torque (N·m)				Angular (°)	Parallel (mm)	End-play (mm)
SFC-29	25	28	18.7	M4	1.7	0.35	3,000	19	10	2	1.5
SFC-38	32	35	23	M4	1.7	1.35	3,000	38	10	2.5	2
SFC-48	43	50	26.5	M5	4	1.8	3,000	60	12	2.5	2
SFC-54	50	59	29.5	M6	7	4.5	3,000	140	12	3	2

### Standard Inner Diameter (ID)

Model	Standard Inner Diameter (d <sub>1</sub> , d <sub>2</sub> ) (mm)									
	4	5	6	8	10	12	14	15	16	
SFC-29	●	●	●	●	●					
SFC-38			●	●	●	●				
SFC-48				●	●	●	●			
SFC-54					●	●	●	●	●	●

※ Keyway is **NOT** available for all sized SFC series.

## SK SERIES



## Schmidt-Kupplung Coupling

## Structure and Material

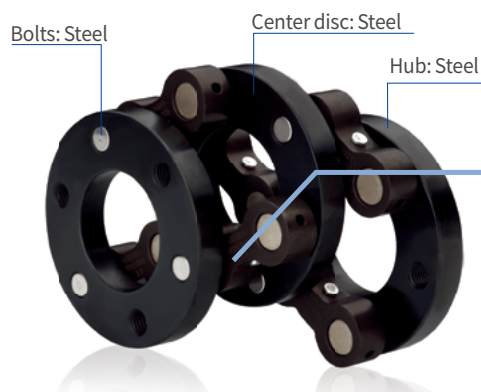

Coupling link: Steel  
Surface treatment: Black-Oxide

Grease nipple

Needle bearings

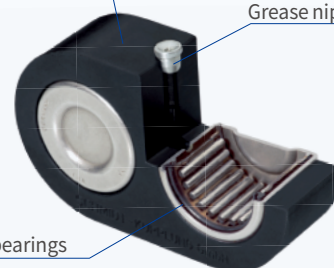

## Product Features &amp; Application

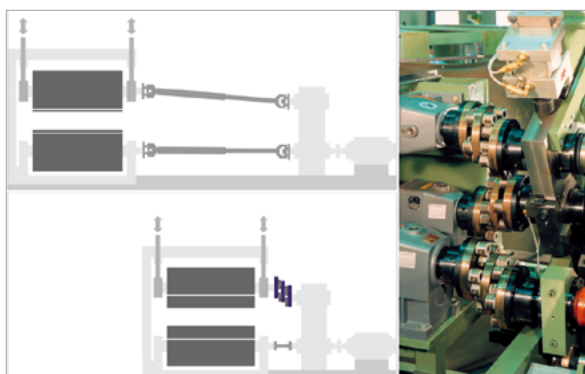

## The most appropriate solution for big misalignment absorption

- Large offset with absolute angle synchronization.
- Precise and compact.
- High torsional stiffness, no restoring forces.

## The optimal solution for every application

- Packaging machines
  - Cartoner modules
  - Box folding machines
  - Thermoforming machines
- Forming industry
  - Metal sheet transport
  - Edge trimming shears
  - Embossing rollers
- Paper machines
  - Breast rollers
  - Paper cutters
  - Rotary cutter systems
- Printing machines
  - Paint rollers
  - Duct rollers
  - Tampon printing machines
- Wood working industry
  - Lamination machines
  - Deburrers
  - Edge processing

## HOW TO ORDER

SK - 10 5 12 / 3

Model Length Offset ØD Numbers of links

# SK SERIES

## Schmidt-Kupplung Coupling

### Radial offset

The Schmidt-Kupplung coupling can be radially offset within the relevant pivoting range. Please note the limits specified in the tables of values for maximum allowable offset, maximum displacement and minimum required offset. Compliance with these values ensures that the shafts of the coupling do not run in an inadmissible alignment or in extended position.

#### Minimal Radial Offset $\Delta K_{r,min}$

The coupling may not operate in alignment position  $K_r=0$ . In alignment position, the center disc would have no definite position in space but would be stimulated to its own movement. Therefore, a minimal required radial offset  $\Delta K_{r,min}$  must be provided for both shafts to be connected. To this end, the output shaft must be moved horizontally (Figure 1) or vertically to achieve this minimum offset.

The figure below illustrates the installation position of the coupling when selecting  $\Delta K_{r,min}$  in the lateral, horizontal direction. The center disc can be located above (Figure 2a) or below (Figure 2b).

For the relevant value of the minimum required radial offset  $\Delta K_{r,min}$  for a coupling size, please refer to the technical data.

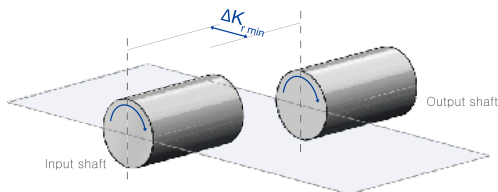

Figure 1. Output shaft moved in the lateral, horizontal direction to achieve the minimum required radial offset

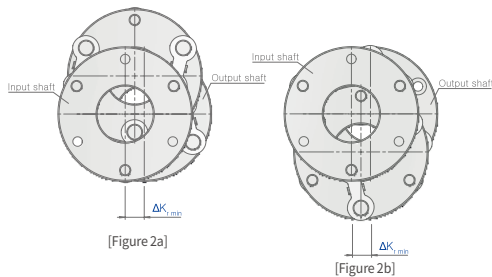

Figure 2. Alternative location of the center disc when selecting  $\Delta K_{r,min}$  in horizontal direction

#### Maximum Radial Offset $\Delta K_r$

The Schmidt-Kupplung coupling is a compactly built coupling for precise torque transmission of extremely radially offset shafts. The height of the maximum permissible radial displacement is dependent on the length/depth gauge of the coupling elements used for the relevant coupling size.

The maximum permissible radial offset results from the sum  $\Delta K_{r,min}$  and the adjustment range (Figure 3). For the relevant value of the maximum permissible radial offset  $\Delta K_r$  for a coupling size, please refer to the technical data.

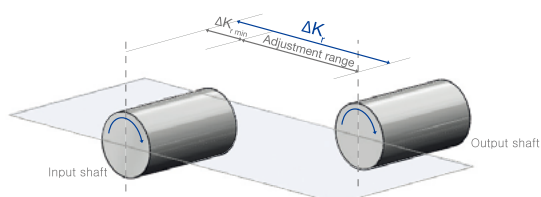

Figure 3. Maximum radial offset

Figure 4 shows the path of the centre disc of the Schmidt-Kupplung coupling with adjusting movements starting at  $\Delta K_{r,min}$  to  $\Delta K_r$ . Here, the center disc moves on a circular portion defined by the length/pitches of the coupling elements and thus always has a definite position.

To determine the exact position of the center disc for required installation space our application engineers will be pleased to assist you.

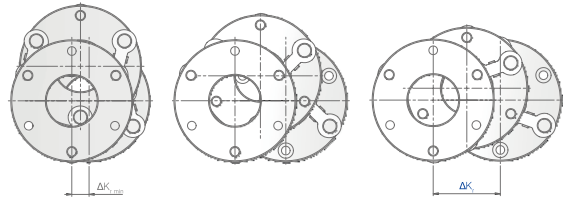
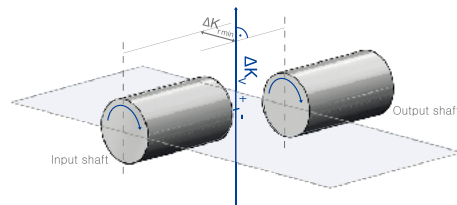

Figure 4. path of the center disc with adjusting movements starting at  $\Delta K_{r,min}$  to  $\Delta K_r$

#### Maximum Linear Range of Coupling $\Delta K_v$



#### Two installation situations are not permitted

##### 1. Inadmissible alignment

The coupling may not operate in alignment position  $K_r=0$  (recognizable in that the coupling elements of link level 1 are parallel to the coupling elements in level 2). In alignment position, the center disc would have no definite position in space but would be stimulated to its own movement. For this reason, the aforementioned

minimum required radial offset must be provided for every Schmidt-Kupplung coupling.

##### 2. Inadmissible extended position

The coupling may not operate in extended position (recognizable in that the coupling elements of link level 1 are parallel to the coupling elements in level 2).

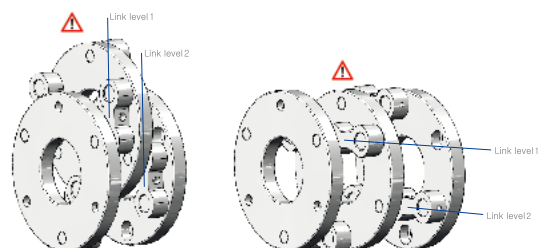

# SK SERIES

## Schmidt-Kupplung Coupling

### Selection sequence

The selection of the Schmidt coupling is determined by the various performance parameters. These include torque, speed and occurring displacement. The influences of these parameters are described below :

#### Selection according to torque

To calculate the dimensioning moment  $T_D$ , please multiply your drive torque  $T_A$  with the corresponding performance factor  $F$  and the expected load factor  $K$ .

$$T_D = T_A \times F \times K$$

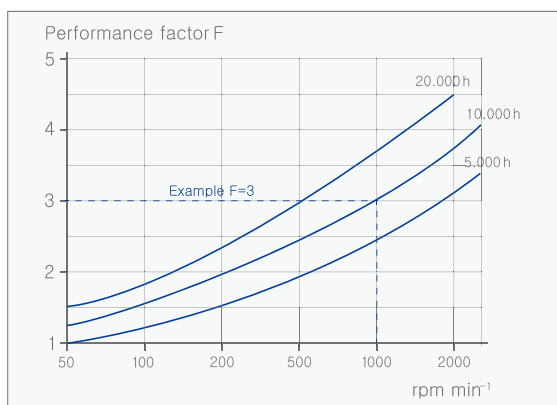

Select the anticipated operating speed of your application combined with the desired service life in hour.

Example: Anticipated operating speed: 1,000 rpm  
Desired service life: 10,000 h

Performance factor  $F$ : 3

Load factor K			
Uniform	Light shocks	Medium shocks	Heavy shocks
1,0	1,25	1,75	2,25

$$T_{KN} > T_D$$

Select a coupling whose rated torque  $T_{KN}$  is larger than the calculated dimensioning torque  $T_D$

※ Make sure that the maximum torque of coupling  $T_{Kmax}$  is not exceeded.

#### Selection example (Application: Roller drive in automatic lamination machine)

##### Required conditions

- Requested maximum radial offset  $\Delta K_r$ : 40mm
- Drive torque  $T_A$ : 50N · m
- Operating speed : 200 rpm
- Desired service life : 10,000 h
- Expected load factor  $K$ : 1.25 (light shocks)

##### Selection

- Performance factor  $F$  : 2
- Dimensional torque  $T_D = 50N \cdot m \times 2 \times 1.25 = 125 N \cdot m$
- Select a coupling whose rated torque  $T_{KN}$  is larger than the calculated dimensioning torque 125 N · m

Appropriate size: SK 7.7.9/3 (TKN: 150 N · m / TKmax: 290 N · m)

#### Lubrication period

The Schmidt-Kupplung, except for size SK 4.2.6/3, SK 4.2.8/5, SK 4.5.6/3 and SK 4.5.8/5, has a lubrication fitting for regreasing. Adequate lubrication is required for full operating life. The Schmidt-Kupplung, should be regreased exclusively with Klüber Staburags NBU 12-300 KP. Mixing lubrication is not recommended and will reduce coupling operating life.

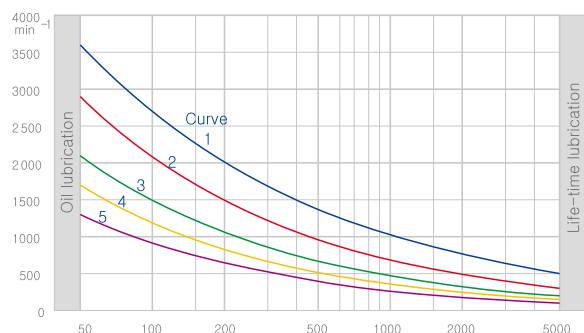

Standard				
Curve 1	Curve 2	Curve 3	Curve 4	Curve 5
SK 7.3.7/3	SK 10.5.12/3	SK 13.6.14/3	SK 16.7.16/3	SK 20.9.20/3
SK 7.3.9/3	SK 10.5.12/4	SK 13.6.16/4	SK 16.10.16/3	SK 20.15.20/3
SK 7.7.9/3	SK 10.9.12/3	SK 13.9.14/3	SK 16.7.18/4	SK 20.9.25/4
SK 7.7.12/4	SK 10.9.14/4	SK 13.9.16/4	SK 16.10.18/4	SK 20.15.25/4

# SK SERIES

## Schmidt-Kupplung Coupling

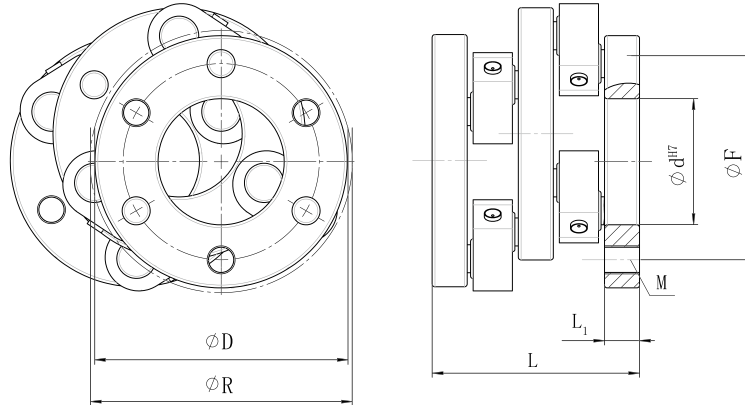

### Dimensions / Performance (Technical Data)

SIZE	Performance							$C_T$ kNm/rad	Dimensions								
	$\Delta K_{r \min}$ mm	$\Delta K_r$ mm	$\Delta K_v$ mm	$\Delta K_w$ °	$T_{KN}$ Nm	$T_{Kmax}$ Nm	$min^{-1}$		D mm	R mm	J kg cm <sup>2</sup>	m kg	L mm	$L_1$ mm	F mm	d mm	M
SK 4.2.6/3	6	23	45	0.8	45	85	2,800	10	60	62	2.8	0.5	44	8	45	25	3xM6
SK 4.2.8/5				0.5	110	210	1,800	24	82	84	8.9	0.8			67	40	5xM6
SK 4.5.6/3	13	50	95	0.8	45	85	1,900	10	60	62	3.1	0.6	44	8	45	25	3xM6
SK 4.5.8/5				0.5	110	210	1,600	24	82	84	9.1	1.1			67	40	5xM6
SK 7.3.7/3	9	34	64	0.8	110	210	3,500	24	70	74	7.5	1.1	74	12.5	48	25	3xM10
SK 7.3.9/3				0.8	150	290	3,100	33	90	94	21.5	1.7			70	45	3xM10
SK 7.7.9/3	17	66	126	0.8	150	290	2,200	33	90	94	24	1.9	74	12.5	70	45	3xM10
SK 7.7.12/4				0.5	280	550	1,900	63	120	124	63	3			98	50	4xM10
SK 10.5.12/3	14	53	100	0.5	360	710	2,300	81	120	120	95	4.5	101	17	90	50	3xM12
SK 10.5.12/4				0.5	480	945	2,300	108	120	120	105	5			90	50	4xM12
SK 10.9.12/3	22	85	162	0.5	360	710	1,700	81	120	120	107	5.1	101	17	90	50	3xM12
SK 10.9.14/4				0.5	590	1,155	1,800	132	140	140	187	6.8			110	50	4xM12
SK 13.6.14/3	17	64	122	0.5	630	1,240	1,700	142	140	143	275	9.8	134	26	100	55	3xM16
SK 13.6.16/4				0.5	1,010	1,980	1,600	227	158	164	475	13			120	60	4xM16
SK 13.9.14/3	22	85	162	0.5	630	1,240	1,500	142	140	143	285	10	134	26	100	55	3xM16
SK 13.9.16/4				0.5	1,010	1,980	1,400	227	158	164	480	13.2			120	60	4xM16
SK 16.7.16/3	18	68	129	0.5	1,130	2,200	1,500	252	158	164	550	15	155	31	115	60	3xM16
SK 16.7.18/4				0.5	1,760	3,440	1,400	395	180	184	680	17			135	70	4xM16
SK 16.10.16/3	25	95	180	0.5	1,130	2,200	1,200	252	158	164	585	16	155	31	115	60	3xM16
SK 16.10.18/4				0.5	1,760	3,440	1,200	395	180	180	910	20			135	70	4xM16
SK 20.9.20/3	22	85	162	0.3	2,160	4,220	1,200	484	200	202	1,500	26	196	33	150	80	3xM20
SK 20.9.25/4				0.3	3,830	7,500	1,000	860	250	252	3,700	41			200	100	4xM20
SK 20.15.20/3	37	142	270	0.3	2,160	4,220	900	484	200	202	1,850	32	196	33	150	80	3xM20
SK 20.15.25/4				0.3	3,830	7,500	800	860	250	252	4,100	44			200	100	4xM20

•  $T_{KN}$ = rated torque,  $T_{Kmax}$ = Maximum torque capacity,  $min^{-1}$ = Max. rpm,  $\Delta K_v$ = Maximum linear range of the coupling,  $\Delta K_r$ = Maximum radial offset capacity,  $\Delta K_{r \min}$ = Min. required radial offset

•  $\Delta K_w$ = Max. angular misalignment capacity,  $C_T$ = Torsional stiffness, J= Moment of inertia, m= Mass, L= Coupling length, M= Numbers of threaded bores x bolt size, F= Bolt circle diameter

• Size SK 4.2.6/3 – SK 16.10.18/4 allows an axial misalignment up to 1mm; Size SK 20.9.20/3 – SK 20.15.25/4 up to 2mm.

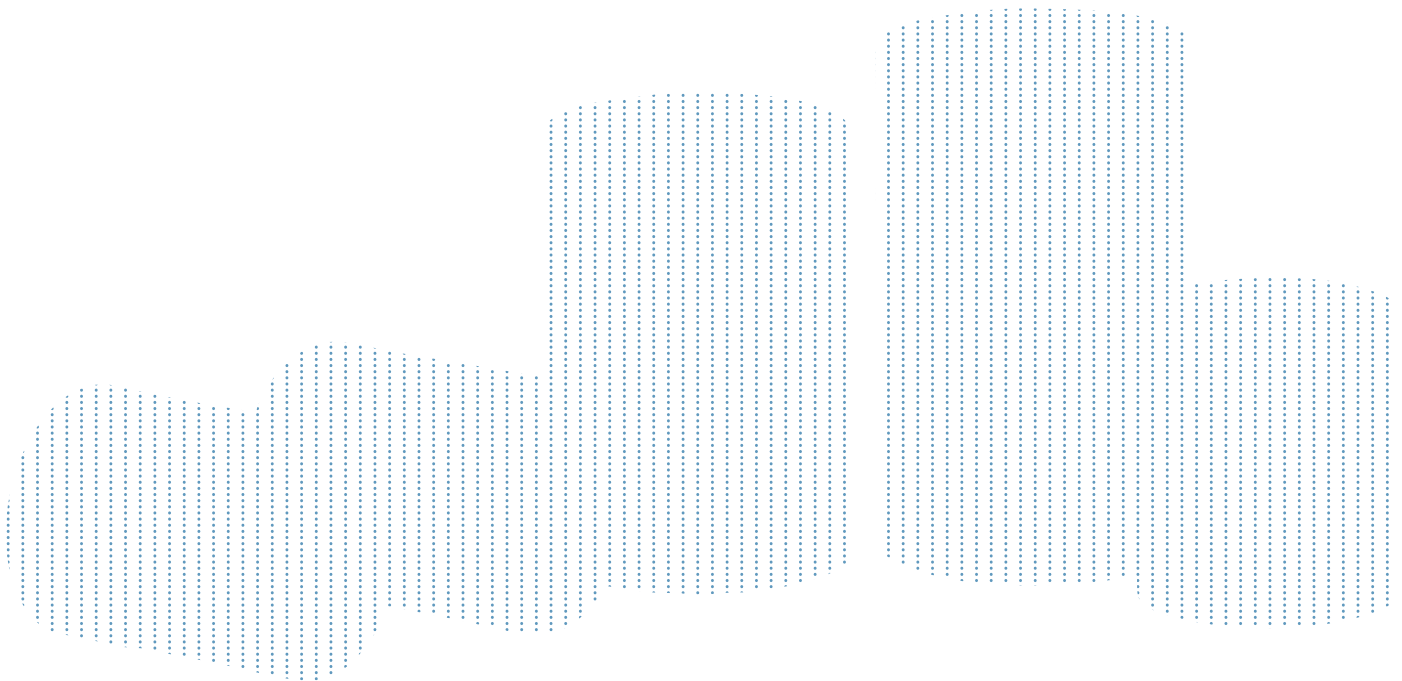

# CONNECTING SHAFT

## Overview

How to determine the proper length(L)	128p
How to calculate permissible parallel misalignment	128p
How to calculate torsional stiffness	128p

## Dimensions / Performance

SJCL Series [Jaw]	129~130p
SHDL Series [High Torque Disk]	131~133p



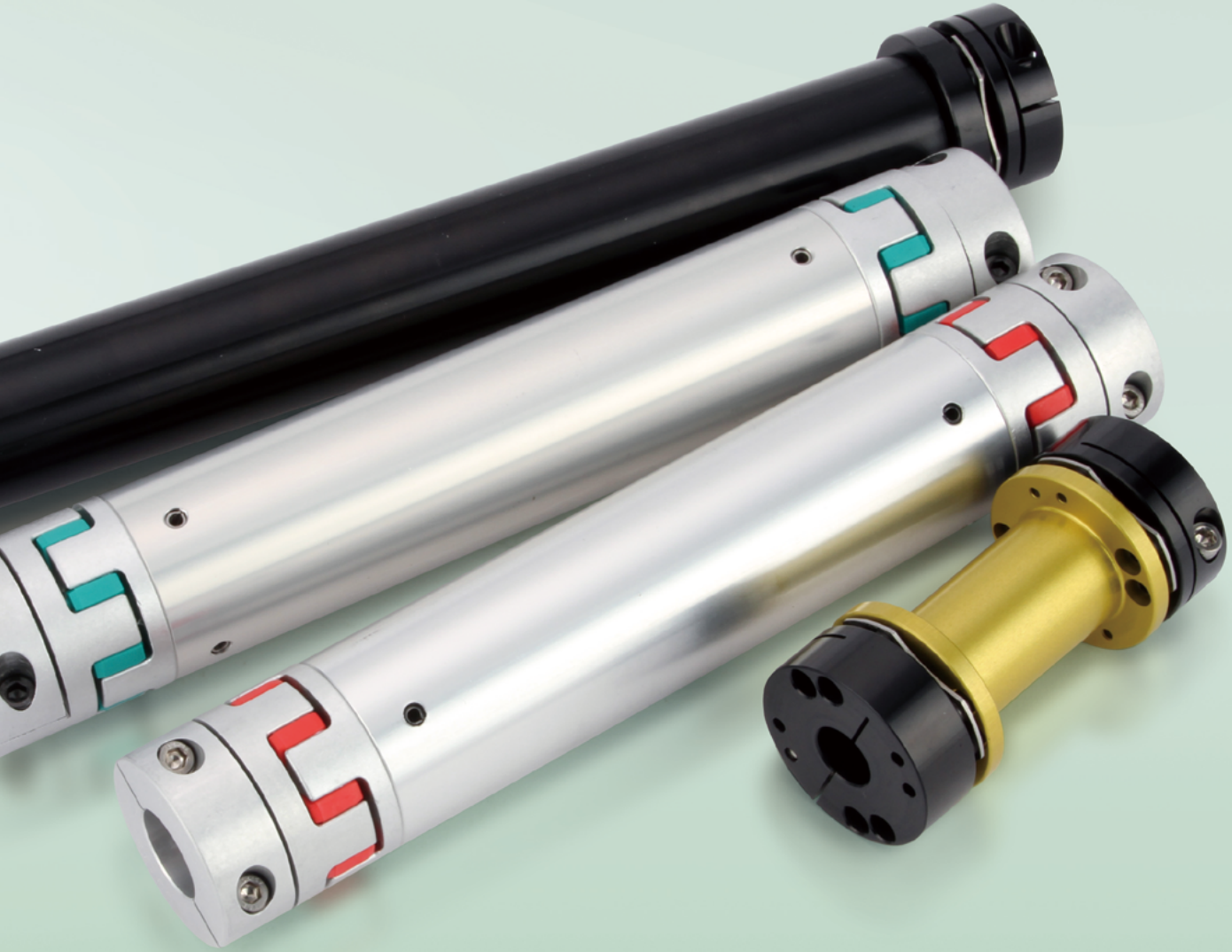

## Why Connecting Shaft?

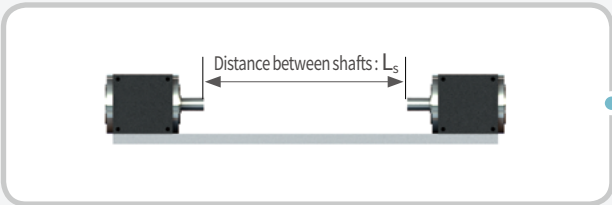

How to transmit motion when there is a longer distance between the shafts?

### Combined set of coupling+ Ground shaft

- 3 different parts (2 Couplings, 1 ground shaft) are separately needed.
- Bigger laboring required
- Hard to keep the appropriate straightness between couplings each end and a ground shaft

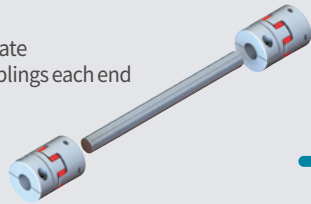

### Connecting Shaft

- 1 Whole piece structure
- Simple installation
- Easy and handy maintenance
- The hollow shaft with high stiffness

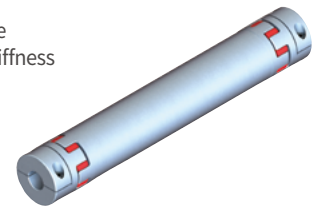

➔ Better

## How to determine the proper length(L)

### General Side-clamp Type

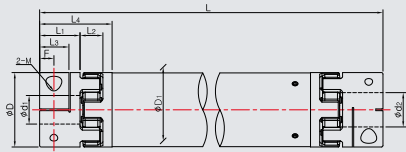

$$L(\text{Total Length}) = L_s(\text{distance between shafts}) + 2L_1$$

### Side-clamp Hub Split Type

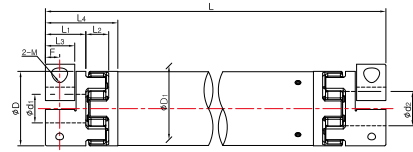

$$L(\text{Total Length}) = L_s(\text{distance between shafts}) + 2L_3$$

※ Side-clamp Hub Split type is commonly used for connecting shaft in regards to an easier maintenance.

## How to calculate permissible parallel misalignment

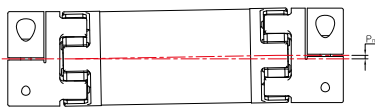

$$P_m = (L - 2(L_1 + L_2)) \times \tan \frac{A_m}{2}$$

$P_m$  = Permissible parallel misalignment

$L$  = Total length

$A_m$  = Permissible angular misalignment of connecting shaft (= 2 x coupling's value)

- The value calculated by the above formula is maximum permissible parallel misalignment in the allowable range of motion transmission, which means sleeves of SJCL and plate spring of SHDL may still get worn down even within the range of permissible parallel misalignment.
- The  $P_m$  value shrinks by  $\frac{1}{2}$  when there are both angular and parallel misalignment at the same time.
- It is recommended to use at the  $\frac{1}{3}$  value  $L$  of  $P_m$  for longer lifespan, as well as keep the shafts located in line as straight as possible.
- If you need any further assistance, please contact Sung-il Customer Service team for more details.

## How to calculate Torsional Stiffness

$$TS_L = \frac{1}{2 \times \frac{1}{TS_C} + \frac{L_{\text{pipe}}}{TS_S}} \quad (\text{N} \cdot \text{m} / \text{rad})$$

$TS_L$  = Torsional Stiffness of Connecting Shaft

$TS_C$  = Torsional Stiffness of Coupling

$TS_S$  = Torsional Stiffness of Pipe/m

$L_{\text{pipe}}$  = Length of Pipe

$$L_{\text{pipe}} = \frac{L - 2L_4}{1000} \quad (\text{m})$$

# SJCL SERIES



## Jaw Type Connecting Shaft

### Structure and Material



Structure	Material	Surface Treatment
Hub	High Strength Aluminum Alloy	Anodizing
Sleeve	Hytrel®(RD/GR) TPU(DG/BL)	-
Hollow Shaft	High Strength Aluminum Alloy	Anodizing
Screw	SCM435	Black Oxide

### Product Features

- High durability (the best feature of SJC series coupling)
- Precise concentricity/straightness
- Minimized moment of inertia by aluminum alloy material
- Absorption of Impact/Vibration
- Easier installation and simpler maintenance

### Max. RPM based on Length

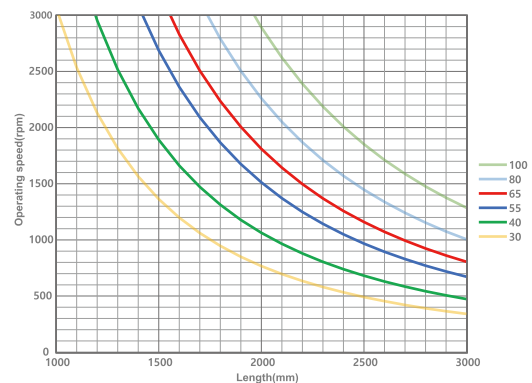

### Parts with Alternative Material Options

- Sung-il Machinery provides alternative material options for Coupling parts for customers who are worried about corrosion on Black oxide finish. Please see the below table for more details.

Mark	Material	Surface treatment
No mark	Steel	Black Oxide
SUS/ASS	Stainless Steel	-

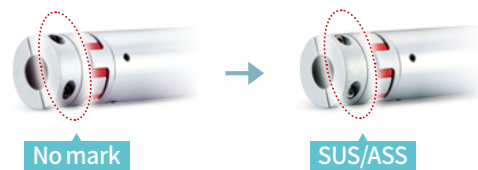

### How to Order

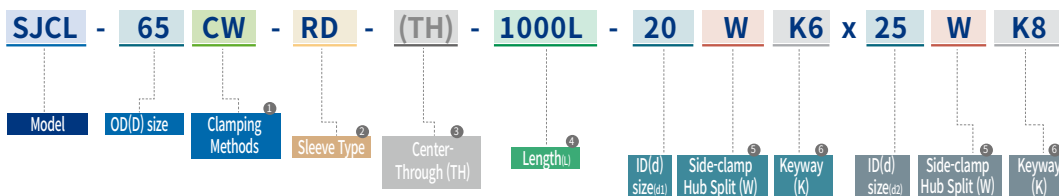

- Clamping Methods**
  - C General Side-clamp
  - CW Side-clamp Hub Split
- Sleeve Type (Shore Hardness)**
  - RD Shore 63D
  - GR Shore 98A
  - BL TPU, Sh87A
  - DG TPU, Sh57D
- Side-clamp Hub Split**
  - No mark Not Split
  - W Split

- Center-Through**
  - No mark Center-Through (Standard)
  - \*TH Please mark "TH" only for SJCBL-30C(CW) size when you need a center-through sleeve.
- Keyway**
  - No mark No Keyway
  - K(b size) Keyway processed according to the indicated b size.
- L (Total Length)**

# SJCL SERIES

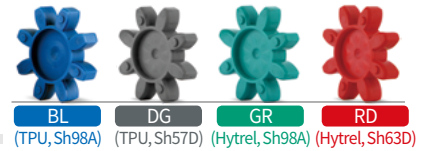

BL (TPU, Sh98A) DG (TPU, Sh57D) GR (Hytrell, Sh98A) RD (Hytrell, Sh63D)

## Jaw Type Connecting Shaft

### Side-clamp

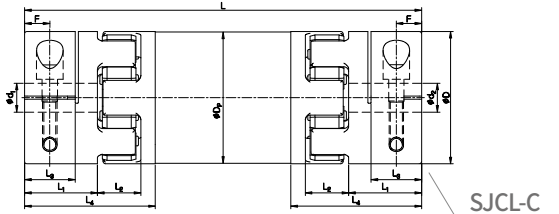

### Side-clamp Hub Split (W)

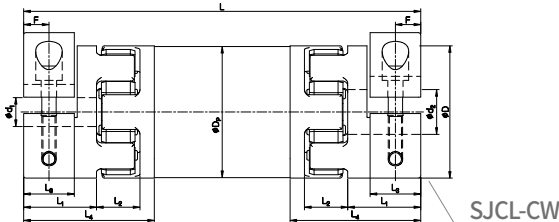

### Dimensions / Performance

Model	Size (±0.3mm)							Screw		Length (mm)		Permissible Torque (N-m)	Maximum Torque (N-m)	Static Torsional Stiffness (N-m/rad)		Moment of Inertia (kg·m <sup>2</sup> )		Permissible Misalignment		
	D	D <sub>p</sub>	L <sub>1</sub>	L <sub>2</sub>	L <sub>3</sub>	L <sub>4</sub>	F	Size	Fastening Torque (N-m)	min.	max.			Coupling [TSc]	PIPE/m [TSs]	Coupling	PIPE/m	Angular (°)	Parallel (mm/m)	End-play (mm)
SJCBL-30□□-GR	30	29.5	15.8	12.4	11.1	32.7	5.4	M4	3.5	95	3,000	12	24	200	1,380	7.5×10 <sup>-6</sup>	1.6×10 <sup>-4</sup>	2	16	-1.0 ~ +1.0
SJCBL-30□□-RD												16	32	220						
SJCBL-40□□-GR	40	39.5	25	16	16.5	45	8.4	M5	8	130	3,000	17	34	1,600	3,800	3.9×10 <sup>-5</sup>	4.3×10 <sup>-4</sup>	2	15.6	-1.0 ~ +1.2
SJCBL-40□□-RD												21	42	1,750						
SJCL-55□□-BL	55	54.5	30.3	18	21	54	10.5	M6	13	175	3,000	60	120	3,000	11,150	1.6×10 <sup>-4</sup>	1.3×10 <sup>-3</sup>	2	15.4	-1.0 ~ +1.4
SJCL-55□□-DG												60	120	4,500						
SJCL-55□□-GR												60	120	4,500						
SJCL-55□□-RD												75	150	6,000						
SJCL-65□□-BL												150	300	6,500						
SJCL-65□□-DG	65	64.5	35.3	20	25.6	63	12.5	M8	30	200	3,000	150	300	8,500	19,310	3.8×10 <sup>-4</sup>	2.2×10 <sup>-3</sup>	2	15.1	-1.2 ~ +1.5
SJCL-65□□-RD												150	300	8,500						
SJCL-80□□-BL												300	600	8,000						
SJCL-80□□-DG												300	600	12,000						
SJCL-80□□-GR	80	79.5	45.2	24	30.2	77	14.7	M10	50	245	3,000	300	600	12,000	37,840	1.0×10 <sup>-3</sup>	4.2×10 <sup>-3</sup>	2	14.6	-1.2 ~ +1.5
SJCL-80□□-RD												300	600	12,000						
SJCL-100□□-BL												380	760	14,000						
SJCL-100□□-DG	104	101.5	56.2	21	39.9	88.2	19.9	M12	90	300	3,000	500	1,000	24,000	100,000	4.6×10 <sup>-3</sup>	1.1×10 <sup>-2</sup>	2	14.4	-1.2 ~ +2.0
SJCL-100□□-RD												500	1,000	24,000						
SJCL-100□□-GR												500	1,000	30,000						
SJCL-100□□-RD												600	1,200	40,000						

- Please modify rated/max. torque value with temperature correction factor when it's higher than 30°C.
- Max. torque/rated torque is the value regarding to a coupling's self-durability and is not related to slip-torque between the coupling bore and the shaft.
- Please contact Sung-il Customer Service team for the special lengths (out of range).

### Standard Inner Diameter (ID)

Model	Standard Inner Diameter (d <sub>1</sub> , d <sub>2</sub> ) (mm)																								
	7	8	9	10	11	12	14	15	16	18	19	20	22	24	25	26	28	30	32	35	40	45	50	55	60
SJCBL-30□□-□□	●	●	●	●	●	●	●																		
SJCBL-40□□-□□		●	●	●	●	●	●																		
SJCL-55□□-□□						●	●	●	●	●	●	●	●	●	●	●	●								
SJCL-65□□-□□							●	●	●	●	●	●	●	●	●	●	●	●	●	●	●				
SJCL-80□□-□□								●	●	●	●	●	●	●	●	●	●	●	●	●	●	●	●	●	●
SJCL-100□□-□□												●	●	●	●	●	●	●	●	●	●	●	●	●	●

- The recommended shaft tolerance is h7.
- Custom process (e.g. non-standard Inner diameter, special tolerance etc.) is also available upon a special request in prior to order placement.
- Keyway is available. (Optional)

# SHDL SERIES



## High Torque Disk Type Connecting Shaft

### Structure and Material



Structure	Material	Surface Treatment
Hub	Ultra High Strength Aluminum Alloy	Anodizing
Plate Spring	Stainless Steel	-
Collar (Spacer)	Steel	Black Oxide
Assembly Screw	SCM435	Black Oxide
Hollow Shaft	High Strength Aluminum Alloy	Anodizing
Fastening Screw	SCM435	Black Oxide

### Product Features

- Enhanced durability with SHD series coupling
- Precise concentricity/straightness
- Minimized moment of inertia by aluminum alloy material
- Backlash free
- High Torsional Stiffness
- Easier installation and simpler maintenance

### Max. RPM based on Length

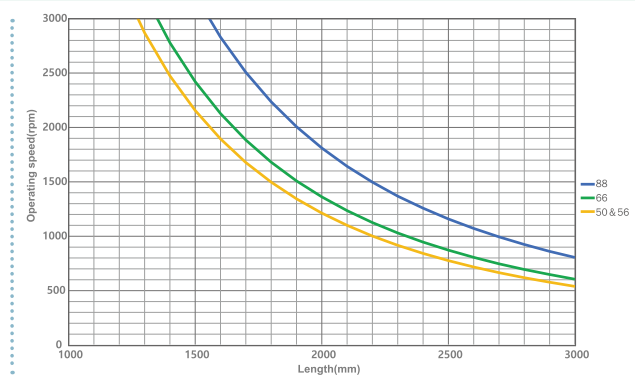

### Parts with Alternative Material Options

- Sung-il Machinery provides alternative material options for Coupling parts for customers who are worried about corrosion on Black oxide finish. Please see the below table for more details.

Mark	Material	Surface treatment
No mark	Steel	Black Oxide
SUS/ASS	Stainless Steel	-



### How to Order

**SHDL - 56 CW - 1000L - 15 W K5 x 20 W K6**

Model    OD(D) size    Clamping Methods    Length(L)    ID(d) size(d1)    Side-clamp Hub Split (W)    Keyway (K)    ID(d) size(d2)    Side-clamp Hub Split (W)    Keyway (K)

- Clamping Methods**
  - C General Side-clamp
  - CW Side-clamp Hub Split
  - T Taper-ring (T)
- L (Total Length)**
- Side-clamp Hub Split**
  - No mark Not Split
  - W Split
- Keyway**
  - No mark No Keyway
  - K(b size) Keyway processed according to the indicated b size. (Keyway is not applicable on Taper-ring type)

# SHDL SERIES

## High Torque Disk Type Connecting Shaft

### Side-clamp

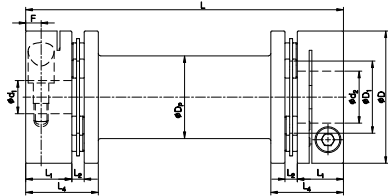

Integral Shaft Type



Inserted Shaft Type

### Side-clamp Hub Split (W)

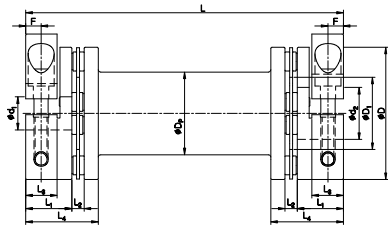

Integral Shaft Type



Inserted Shaft Type

### Dimensions / Performance

#### Integral Shaft Type

Model	Size (±0.3mm)							Screw		Length (mm)		Permissible Torque (N·m)	Static Torsional Stiffness (N·m/rad)			Permissible Misalignment		
	D	D <sub>p</sub>	D <sub>1</sub>	L <sub>1</sub>	L <sub>2</sub>	L <sub>3</sub>	F	Size	Fastening Torque (N·m)	min.	max.		Coupling [TSc]	Shaft (min. length)	Shaft (max. length)	Angular (°)	Parallel (mm)	End-play (mm)
SHDL-50□□	50	29	26.1	16.3	3.3	11	5.5	M5	8	60	110	25	1.4×10 <sup>4</sup>	7.3×10 <sup>4</sup>	2.2×10 <sup>4</sup>	1.4	0.5	± 1.2
SHDL-56□□	56	35	30.6	19.5	5.2	13.3	6.5	M6	13	80	130	35	2.0×10 <sup>4</sup>	8.6×10 <sup>4</sup>	3.6×10 <sup>4</sup>	1.4	0.5	± 1.2
SHDL-66□□	66	41	35.6	24.5	7.5	15.5	7.5	M6	13	100	150	60	3.0×10 <sup>4</sup>	1.4×10 <sup>5</sup>	6.0×10 <sup>4</sup>	1.4	0.5	± 1.6
SHDL-88□□	88	55	46.1	30	9.9	19	9.9	M8	30	120	170	180	7.0×10 <sup>4</sup>	3.4×10 <sup>5</sup>	1.5×10 <sup>5</sup>	1.4	0.5	± 2.0

#### Inserted Shaft Type

Model	Size (±0.3mm)								Screw		Length (mm)		Permissible Torque (N·m)	Static Torsional Stiffness (N·m/rad)		Moment of Inertia (kg·m <sup>2</sup> )		Permissible Misalignment		
	D	D <sub>p</sub>	D <sub>1</sub>	L <sub>1</sub>	L <sub>2</sub>	L <sub>3</sub>	L <sub>4</sub>	F	Size	Fastening Torque (N·m)	min.	max.		Coupling [TSc]	PIPE/m [TSS]	coupling	PIPE/m	Angular (°)	Parallel (mm)	End-play (mm)
SHDL-50□□	50	44.5	26.1	16.3	3.3	11	29.6	5.5	M5	8	110	3,000	25	1.4×10 <sup>4</sup>	6,000	1.2×10 <sup>-4</sup>	6.4×10 <sup>-4</sup>	1.4	11	± 1.2
SHDL-56□□	56	44.5	30.6	19.5	5.2	13.3	34.7	6.5	M6	13	130	3,000	35	2.0×10 <sup>4</sup>	6,000	2.0×10 <sup>-4</sup>	6.4×10 <sup>-4</sup>	1.4	11.1	± 1.2
SHDL-66□□	66	49.5	35.6	24.5	7.5	15.5	43	7.5	M6	13	150	3,000	60	3.0×10 <sup>4</sup>	8,000	4.5×10 <sup>-4</sup>	9.0×10 <sup>-4</sup>	1.4	10.8	± 1.6
SHDL-88□□	88	64.5	46.1	30	9.9	19	52.9	9.9	M8	30	170	3,000	180	7.0×10 <sup>4</sup>	20,000	1.7×10 <sup>-3</sup>	2.2×10 <sup>-3</sup>	1.4	10.6	± 2.0

• Please contact Sung-il Customer Service team for the special lengths (out of range).

### Standard Inner Diameter (ID)

Model	Standard Inner Diameter (d <sub>1</sub> , d <sub>2</sub> ) (mm)																				
	10	11	12	14	15	16	18	19	20	22	24	25	26	28	30	32	35	38	40	42	45
SHDL-50□□	●	●	●	●	●	●	●	●	●	●	●	●	●	●	●	●	●	●	●	●	●
SHDL-56□□	●	●	●	●	●	●	●	●	●	●	●	●	●	●	●	●	●	●	●	●	●
SHDL-66□□					●	●	●	●	●	●	●	●	●	●	●	●	●	●	●	●	●
SHDL-88□□									●	●	●	●	●	●	●	●	●	●	●	●	●

- The recommended shaft tolerance is h7.
- Custom process (e.g. non-standard Inner diameter, special tolerance etc.) is also available upon a special request in prior to order placement.
- Keyway is available. (Optional)

# SHDL SERIES

## High Torque Disk Type Connecting Shaft

### Taper-ring

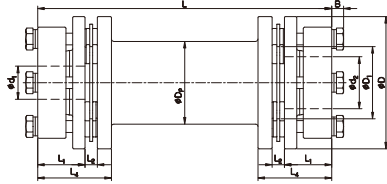

Integral Shaft Type



Inserted Shaft Type

### Dimensions / Performance

#### Integral Shaft Type

Model	Size ( $\pm 0.3\text{mm}$ )							Screw		Length (mm)		Permissible Torque (N-m)	Static Torsional Stiffness (N-m/rad)		Permissible Misalignment		
	D	D <sub>p</sub>	D <sub>1</sub>	L <sub>1</sub>	L <sub>2</sub>	L <sub>4</sub>	B	Size	Fastening Torque (N-m)	min.	max.		coupling [TSc]	PIPE/m [TSS]	Angular (°)	Parallel (mm)	End-play (mm)
SHDL-56T	56	35	30.6	20.2	5.2	31.4	4.5	M6	13	80	130	35	$2.0 \times 10^4$	$1.6 \times 10^4$	1.4	0.5	$\pm 1.2$
SHDL-66T	66	41	35.6	25	7.5	40.5	5	M6	13	100	150	60	$3.0 \times 10^4$	$2.9 \times 10^4$	1.4	0.5	$\pm 1.6$
SHDL-88T	88	55	46	30	9.9	49.9	5	M8	30	120	170	180	$7.0 \times 10^4$	$6.0 \times 10^4$	1.4	0.5	$\pm 2.0$

#### Inserted Shaft Type

Model	Size ( $\pm 0.3\text{mm}$ )							Screw		Length (mm)		Permissible Torque (N-m)	Static Torsional Stiffness (N-m/rad)		Moment of Inertia (kg-m <sup>2</sup> )		Permissible Misalignment		
	D	D <sub>p</sub>	D <sub>1</sub>	L <sub>1</sub>	L <sub>2</sub>	L <sub>4</sub>	B	Size	Fastening Torque (N-m)	min.	max.		coupling [TSc]	PIPE/m [TSS]	coupling	PIPE/m	Angular (°)	Parallel (mm)	End-play (mm)
SHDL-56T	56	44.5	30.6	20.2	5.2	35.4	4.5	M6	13	130	3,000	35	$2.0 \times 10^4$	6,000	$3.8 \times 10^{-5}$	$1.5 \times 10^{-4}$	1.4	11.1	$\pm 1.2$
SHDL-66T	66	49.5	35.6	25	7.5	43.5	5	M6	13	150	3,000	60	$3.0 \times 10^4$	8,000	$9.3 \times 10^{-5}$	$2.7 \times 10^{-4}$	1.4	10.8	$\pm 1.6$
SHDL-88T	88	64.5	46	30	9.9	52.9	5	M8	30	170	3,000	180	$7.0 \times 10^4$	20,000	$3.8 \times 10^{-4}$	$8.5 \times 10^{-4}$	1.4	10.6	$\pm 2.0$

- Please contact Sung-il Customer Service team for the special lengths (out of range).

### Standard Inner Diameter (ID)

Model	Standard Inner Diameter (d <sub>1</sub> , d <sub>2</sub> ) (mm)																				
	10	11	12	14	15	16	18	19	20	22	24	25	26	28	30	32	35	38	40	42	45
SHDL-56T	●	●	●	●	●	●	●	●	●	●	●	●									
SHDL-66T					●	●	●	●	●	●	●	●	●	●	●	●					
SHDL-88T									●	●	●	●	●	●	●	●	●	●	●	●	●

- The recommended shaft tolerance is h7.
- Custom process (e.g. non-standard Inner diameter, special tolerance etc.) is also available upon a special request in prior to order placement.
- Keyway is **NOT** available.

# SAFETY COUPLING

## Overview

Why Safety Coupling?	136p
Safety Coupling Line-up	136p
Product Features	136p
Structure	137p
Operating Principles (How it works)	137p
Additional Sensor Attachment	137p
Disengagement Torque Set-up Guide	137p

## Dimensions / Performance

STL Series [Coupling attached Type]	138~139p
STL-F Series [Flange Type]	140~141p

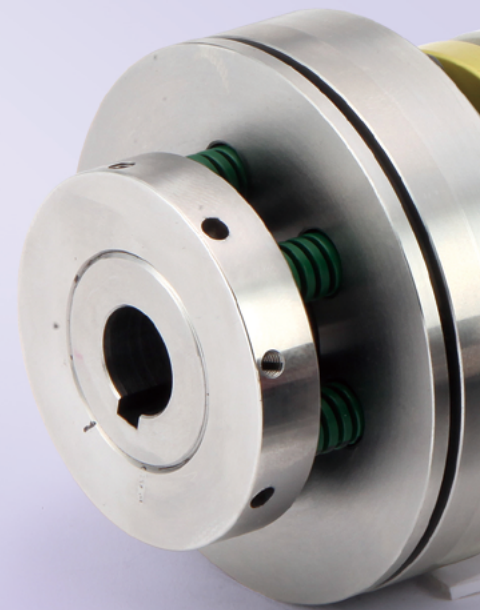



## Why Safety Coupling?

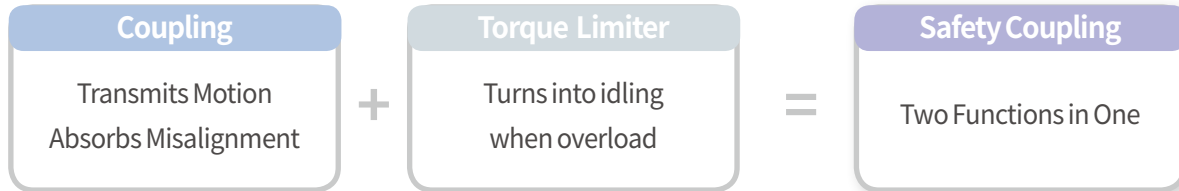

## Safety Coupling Line-up

### Coupling attached Type



- For connection between shafts
- Absorption of parallel/angular misalignment

### Flange Type

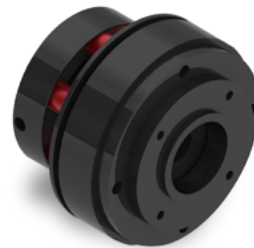

- For attachment to different objects (e.g. timing pulley, sprocket, etc.)

## Product Features

1. Wide range of standard preset torque values
2. Absorption of misalignment by plate springs. (Disk Coupling attached type Only)
3. Easier torque adjustment with an adjusting nut and an indicator of spring pressure amount
4. Various assembly options according to each clamping objects

## Structure

## Disk Coupling Attached Type (STL)

Disk Coupling Section

Coupling Hub  
Plate Spring  
Middle Plate  
Plate Spring

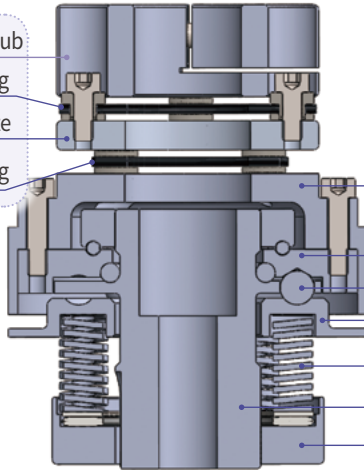

## Flange Type (STL-F)

Cover  
Ball-plate  
Ball  
Ball Guide  
Spring  
Main Hub  
Adjusting Nut

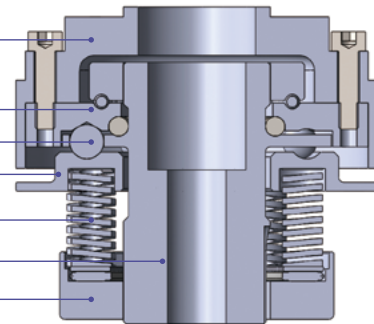

## Operating Principles (How it works)

- If torque is overloaded (exceeded the disengagement set value), balls fixed on the V pocket-shaped ball plate push the ball guide while getting out of the ball plate. And then idle operation occurs between the coupling section and the main hub, which enables to mechanically cut off motion.

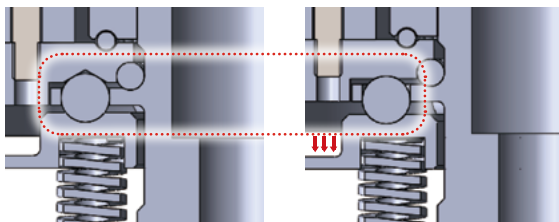

Normal Operation

Idle Operation

## Additional Sensor Attachment

Ball guide pushed when overloaded ⇨

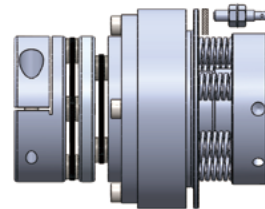

- You may know how far the ball guide is pushed using an additional limit switch or a proximity sensor attached underneath the ball guide. It means you can link them to the driving part (e.g. motor etc.) to automatically stop the motion. (Please refer to "X" value in the "Dimensions / Performance" tables for the distance how far ball guide is pushed)
- If you decide to use a proximity sensor together, make sure you check if the sensor senses the actual location of the ball guide, by making the safety coupling idle with the intentional manual overload for test.

## Disengagement Torque Set-up Guide

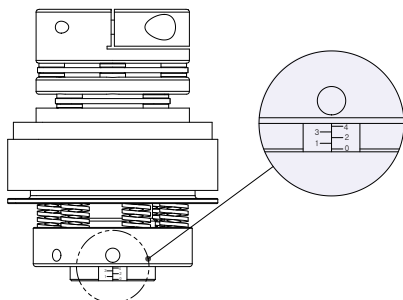

- Fasten the adjusting nut by ticks on the main hub according to disengagement torque information by each spring pressure gauge.
- The harder fastening, the higher slip torque.
- The margin of error (between disengagement torque to actual slip torque) is smaller than  $\pm 10\%$ .

# STL SERIES

## Safety Coupling for Torque Overload Protection (Coupling attached Type)

### General Set-screw Type

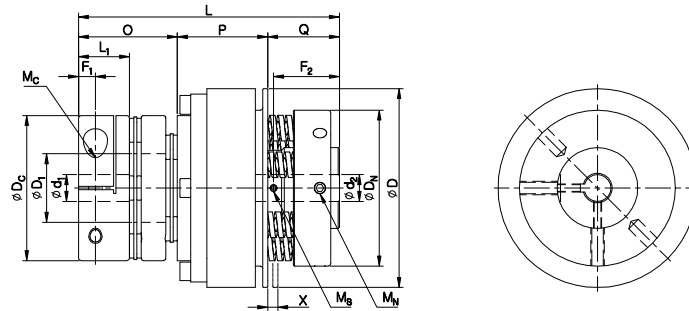

### A.P. LOCK Type

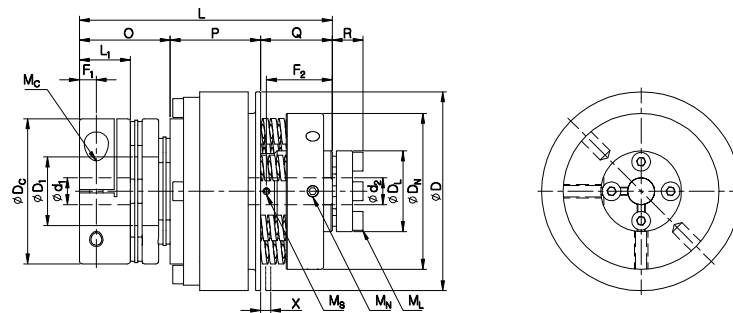

### Dimensions / Performance

Model	Torque Range (N·m)	Spring		Size(± 0.3mm)													
		Color	Q'ty	D	D <sub>C</sub>	D <sub>1</sub>	D <sub>N</sub>	D <sub>L</sub>	L	L <sub>1</sub>	O	P	Q	R	X	F <sub>1</sub>	F <sub>2</sub>
STL25-L	1.5 ~ 7	BLUE	3	74	54	25	58	30	95.6	19	34.8	33.6	27.2	12.5	1.2	6.3	24.5
STL25-M	4.5 ~ 20	RED	6														
STL25-H	9 ~ 25	GREEN	6														
STL55-L	7.5 ~ 27	BLUE	6	104	80	35	70	40	120.8	29.7	52.1	42.9	25.8	14.5	1.3	9.4	20.5
STL55-M	13.5 ~ 41	RED	6														
STL55-H	21 ~ 55	GREEN	6														
STL150-L	20 ~ 50	BLUE	5	125	88	46	90	55	144.9	30	69.8	49.1	26	14.5	2.1	10	20.5
STL150-M	30 ~ 80	RED	5														
STL150-H	55 ~ 150	GREEN	10														

Model	M <sub>C</sub>		M <sub>S</sub>		M <sub>N</sub>		M <sub>L</sub>		Max. rpm (min <sup>-1</sup> )	Moment of Inertia (kg·m <sup>2</sup> )	Mass (kg)	Permissible Misalignment		
	Size	Fastening Torque	Size	Fastening Torque	Size	Fastening Torque	Size	Fastening Torque				Angular (°)	Parallel (mm)	End-play (mm)
STL25-L	2-M5	8	2-M3	0.7	2-M4	1.7	4-M4	3.5	700	7.1×10 <sup>-4</sup>	1.2	0.6	0.1	±0.5
STL25-M														
STL25-H														
STL55-L	1-M8	30	2-M4	1.7	2-M5	4	6-M4	3.5	550	3.3×10 <sup>-3</sup>	3	0.6	0.1	±0.5
STL55-M														
STL55-H														
STL150-L	1-M8	30	2-M6	7	2-M6	7	6-M4	3.5	400	8.3×10 <sup>-3</sup>	4.8	1	0.2	±0.6
STL150-M														
STL150-H														

# STL SERIES

## Safety Coupling for Torque Overload Protection (Coupling attached Type)

### Standard Inner Diameter (ID)

Model			Standard Inner Diameter (d <sub>1</sub> , d <sub>2</sub> ) (mm)																					
			10	11	12	14	15	16	17	18	19	20	21	22	24	25	28	30	32	35	38	40	42	45
STL25	d <sub>1</sub> Coupling side	General	●	●	●	●	●	●	●	●	●	●	●	●	●									
	d <sub>2</sub> Torque Limiter side	General Set-screw	●	●	●	●	●																	
		A.P. Lock	●	●	●																			
STL55	d <sub>1</sub> Coupling side	General					●	●	●	●	●	●	●	●	●	●	●	●	●					
	d <sub>2</sub> Torque Limiter side	General Set-screw				●	●	●	●	●	●	●	●	●	●									
		A.P. Lock				●	●	●	●	●	●													
STL150	d <sub>1</sub> Coupling side	General												●	●	●	●	●	●	●	●	●	●	●
	d <sub>2</sub> Torque Limiter side	General Set-screw					●	●	●	●	●	●	●	●	●	●	●	●	●					
		A.P. Lock					●	●	●	●	●	●	●	●	●	●	●	●	●					

### Tightening amount – Slip torque correlation chart

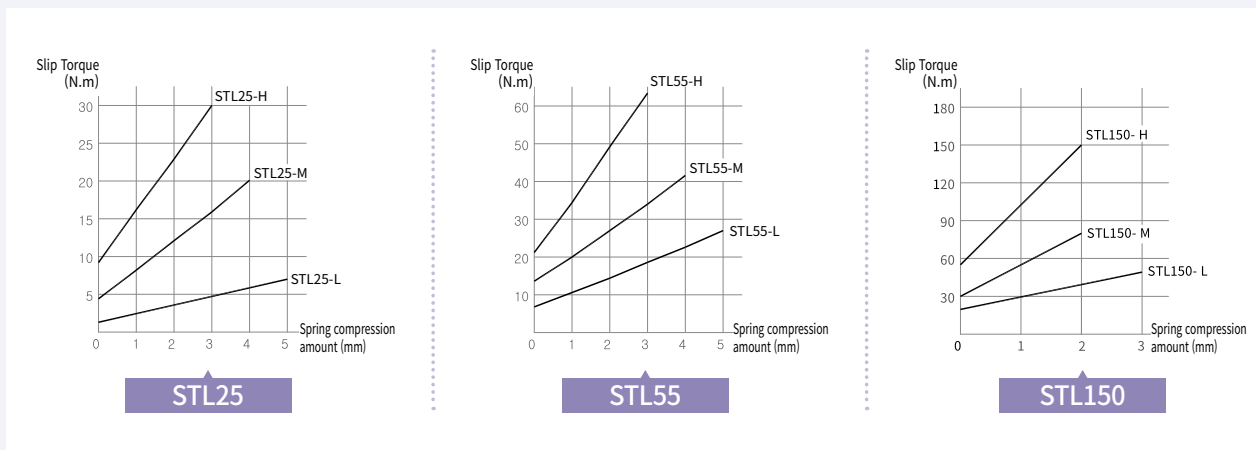

### How to Order

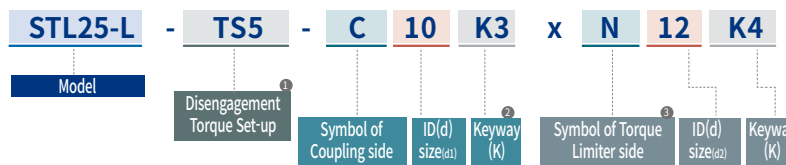

#### 1 Disengagement Torque Set-up

No mark User's own set-up  
 TS(torque) Already set-up at a certain torque at the dispatch stage

#### 2 Keyway

No mark No Keyway  
 K(b size) Keyway processed according to the indicated b size. (Keyway is not applicable on A.P. Lock type)

#### 3 Clamping way of torque limiter side

N General Set-screw Type  
 P A.P. Lock Type

※ N type products (General set-screw on Torque limiter side) should be accompanied with key/keyway due to structural reasons. If the size of keyway is non-standard, please contact our customer service team.

(In case your device cannot have a key, please make sure you discuss with our customer service team before placing an order.)

※ Due to its structural conditions, STL series cannot be modified once it is processed.

# STL-F SERIES

## Safety Coupling for Torque Overload Protection (Flange Type)

### General Set-screw

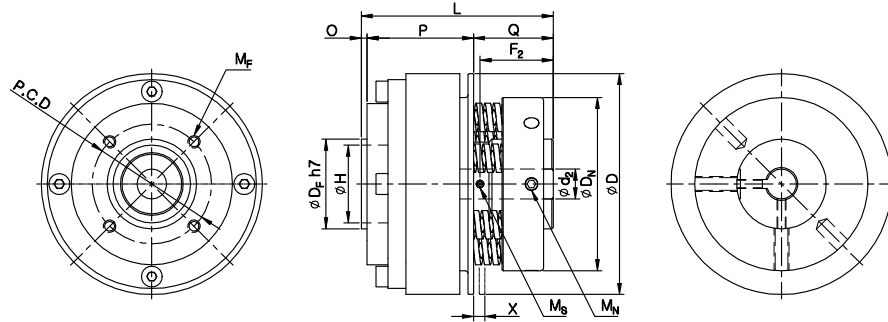

### A.P. LOCK Type

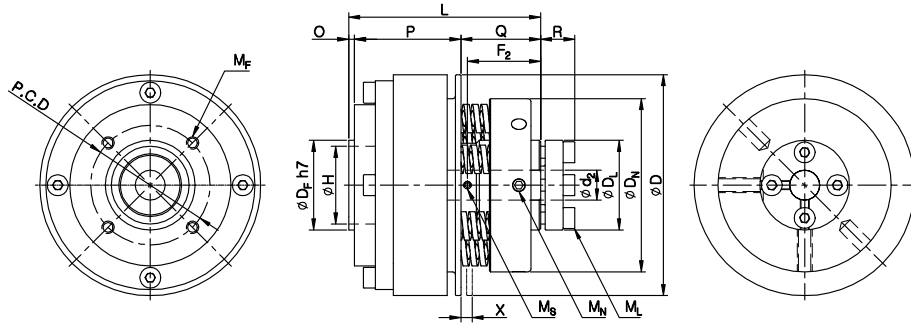

### Dimensions / Performance

Model	Torque Range (N·m)	Spring		Size(± 0.3mm)											
		Color	Q'ty	D	D <sub>F</sub>	D <sub>N</sub>	D <sub>L</sub>	L	H	O	P	Q	R	X	F <sub>2</sub>
STL25F-L	1.5 ~ 7	BLUE	3	74	30	58	30	64.8	24	2	35.6	27.2	12.5	1.2	24.5
STL25F-M	4.5 ~ 20	RED	6												
STL25F-H	9 ~ 25	GREEN	6												
STL55F-L	7.5 ~ 27	BLUE	6	104	45	70	40	71.9	40	3	42.9	26	14.5	1.3	20.5
STL55F-M	13.5 ~ 41	RED	6												
STL55F-H	21 ~ 55	GREEN	6												
STL150F-L	20 ~ 50	BLUE	5	125	60	90	55	80.1	52	4	50.1	26	14.5	2.1	20.5
STL150F-M	30 ~ 80	RED	5												
STL150F-H	55 ~ 150	GREEN	10												

Model	M <sub>F</sub>		M <sub>S</sub>		M <sub>N</sub>		M <sub>L</sub>		Max. rpm (min <sup>-1</sup> )	Moment of Inertia (kg·m <sup>2</sup> )	Mass (kg)
	Size	P.C.D.	Size	Fastening Torque	Size	Fastening Torque	Size	Fastening Torque			
STL25F-L	4-M4 DP8	40	2-M3	0.7	2-M4	1.7	4-M4	3.5	700	6.4×10 <sup>-4</sup>	1.1
STL25F-M											
STL25F-H											
STL55F-L	6-M6 DP8	60	2-M4	1.7	2-M5	4	6-M4	3.5	550	2.1×10 <sup>-3</sup>	2.4
STL55F-M											
STL55F-H											
STL150F-L	6-M8 DP10	75	2-M6	7	2-M6	7	6-M4	3.5	400	7.2×10 <sup>-3</sup>	3.9
STL150F-M											
STL150F-H											

# STL-F SERIES

## Safety Coupling for Torque Overload Protection (Flange Type)

### Standard Inner Diameter (ID)

Model		Standard Inner Diameter (d <sub>1</sub> , d <sub>2</sub> ) (mm)																	
		10	11	12	14	15	16	17	18	19	20	21	22	24	25	28	30	32	35
STL25F	General Set-screw	●	●	●	●	●													
	A.P. Lock	●	●	●															
STL55F	General Set-screw				●	●	●	●	●	●	●	●	●						
	A.P. Lock				●	●	●	●	●	●	●								
STL150F	General Set-screw					●	●	●	●	●	●	●	●	●	●	●	●	●	●
	A.P. Lock					●	●	●	●	●	●	●	●	●	●	●	●	●	●

### Tightening amount – Slip torque correlation chart

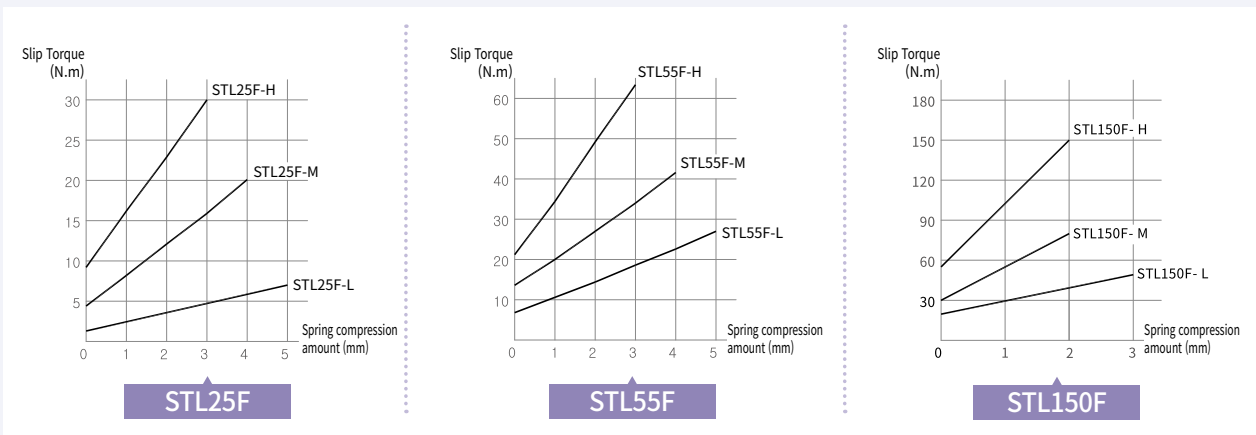

### How to Order

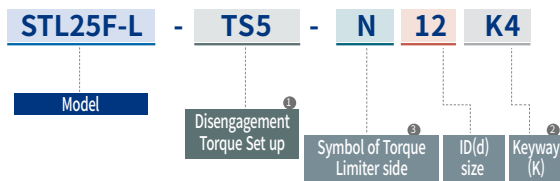

① Disengagement Torque Set-up  
 No mark / User's own set-up  
 TS(torque) / Already set-up at a certain torque at the dispatch stage

② Keyway  
 No mark / No Keyway  
 K(b size) / Keyway processed according to the indicated b size. (Keyway is not applicable on A.P. Lock type)

③ Clamping way of torque limiter side  
 N / General Set-screw Type  
 P / A.P. Lock Type

※ N type products (General set-screw on Torque limiter side) should be accompanied with key/keyway due to structural reasons. If the size of keyway is non-standard, please contact our customer service team.

(In case your device cannot have a key, please make sure you discuss with our customer service team before placing an order.)

※ Due to its structural conditions, STL series cannot be modified once it is processed.

# TIMING PULLEY

## Overview

INDEX (Timing Pulley)	144~145p
Eagle Timing Pulley	146p
Product Features & Tolerance	147p
Clamping Methods	148p
Installation Guide	148p
Additional Information about Clamping Methods	149~150p
Made-To-Order Process	150p

## Dimensions / Performance

SATP-S3M SERIES	151~157p
SATP-S5M SERIES	158~165p
SATP-S8M SERIES	166~171p
SATP-1.5GT SERIES	172p
SATP-2GT SERIES	173p
SATP-3GT SERIES	174~180p
SATP-5GT SERIES	181~187p
SATP-8YU SERIES	188~193p



# INDEX (TIMING PULLEY)

TYPE	SPA □ A.P.LOCK		SPB TAPER BUSHING	
Shape				
	I TYPE	O TYPE	I TYPE	O TYPE

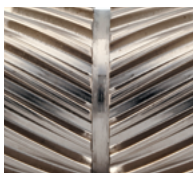
EAGLE PULLEY series		TYPE	5M	8M	10M	14M
		No. of Tooth(NT)	15 ~	18 ~	15 ~	28 ~
		Belt Width(BW)	12.5, 25	16, 25, 32, 50, 64	25, 32, 50, 75, 100	35, 52.5, 70, 105
		Pitch: 5 / 8 / 10 / 14mm	PAGE	146p		

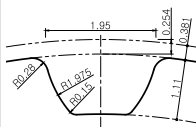

※ Since this pulley type is manufactured entirely according to the customer's specifications, please discuss the details with our sales team in advance.

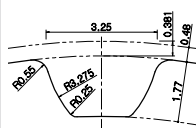
S3M series		Item	SATP-S3M-NT□□-BW□□□			
		TYPE	SPA □	SPB	SC	ID □□
		No. of Tooth(NT)	30 ~ 72	34 ~ 72	24 ~ 60	30 ~ 60
		Belt Width(BW)	10, 15	10, 15	6, 10	10, 15
		Pitch: 3mm	PAGE	152~153p	154p	155p

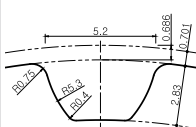
S5M series		Item	SATP-S5M-NT□□-BW□□□			
		TYPE	SPA □	SPB	SC	ID □□
		No. of Tooth(NT)	20 ~ 72	22 ~ 72	24 ~ 60	20 ~ 44
		Belt Width(BW)	10, 15, 25	10, 15, 25	10, 15	10, 15, 25
		Pitch: 5mm	PAGE	158~159p	161p	162p

S8M series		Item	SATP-S8M-NT□□-BW□□□			
		TYPE	SPA □	SPB	SC	ID □□
		No. of Tooth(NT)	19 ~ 72	18 ~ 72	20 ~ 36	20 ~ 40
		Belt Width(BW)	15, 25, 30, 40	15, 25, 30, 40	15, 25	15, 25, 30, 40
		Pitch: 8mm	PAGE	167p	168p	169p

# INDEX (TIMING PULLEY)

TYPE	SC SIDE-CLAMP	ID□□ IDLER		
Shape				
		IDOC TYPE	IDTC TYPE	IDTS TYPE

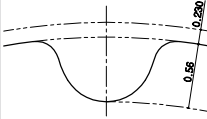
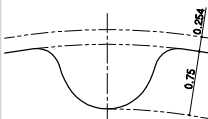
1.5GT series		Item	SATP-1.5GT-NT□□-BW□□□		2GT series		Item	SATP-2GT-NT□□-BW□□□	
		TYPE	SC				SC		
		No. of Tooth(NT)	36 ~ 48			No. of Tooth(NT)	27 ~ 72		
		Belt Width(BW)	3			Belt Width(BW)	4, 6		
	Pitch: 1.5mm	PAGE	172p			Pitch: 2mm	PAGE	173p	

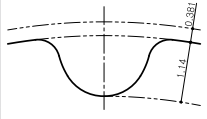
3GT series		Item	SATP-3GT-NT□□-BW□□□			
		TYPE	SPA□	SPB	SC	ID□□
		No. of Tooth(NT)	30 ~ 60	34 ~ 60	24 ~ 60	30 ~ 60
		Belt Width(BW)	9, 15	9, 15	6, 9	9, 15
	Pitch: 3mm	PAGE	175 ~ 176p	177p	178p	179 ~ 180p

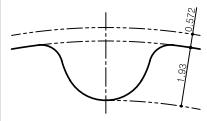
5GT series		Item	SATP-5GT-NT□□-BW□□□			
		TYPE	SPA□	SPB	SC	ID□□
		No. of Tooth(NT)	20 ~ 60	22 ~ 60	24 ~ 60	20 ~ 40
		Belt Width(BW)	12, 15	12, 15	12, 15	12, 15
	Pitch: 5mm	PAGE	182 ~ 183p	184p	185p	186 ~ 187p

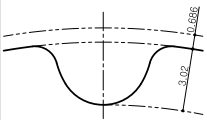
8YU series		Item	SATP-8YU-NT□□-BW□□□			
		TYPE	SPA□	SPB	SC	ID□□
		No. of Tooth(NT)	20 ~ 60	20 ~ 60	20 ~ 36	20 ~ 40
		Belt Width(BW)	15, 20, 25	15, 20, 25	15, 25	15, 25
	Pitch: 8mm	PAGE	189p	190p	191p	192 ~ 193p

# TIMING PULLEY OVERVIEW

## EAGLE TIMING PULLEY

This timing pulley product features a helical tooth profile design. During operation, the belt and pulley teeth engage progressively and continuously. This design reduces noise and minimizes wear. Additionally, it decreases vibrations, resulting in improved power transmission performance compared to other types of timing pulleys (trapezoidal, curvilinear, etc.).

## EAGLE TIMING PULLEY - Features

### Low noise / Low vibration

The design, optimized with a helical offset tooth profile, allows for continuous engagement between the belt and pulley. This structure is designed to drastically reduce vibrations and noise that may occur during operation, enabling quiet and smooth operation.

### Self-alignment

The helical offset design features a V-shaped tooth arrangement. This tooth arrangement allows for self-alignment of the timing belt during operation, effectively preventing lateral movement. As a result, flanges, which are essential in other types of timing pulleys, are no longer necessary. This allows for a reduction in the pulley's width and weight, resulting in a more compact and lightweight drive system overall.

### High efficiency

The application of the helical tooth design ensures excellent performance even at high rotational speeds. The continuous engagement between the belt and pulley maximizes power transmission efficiency while minimizing friction and vibration, significantly improving durability. This design reduces wear under high-speed operating conditions and extends the system's lifespan, ultimately lowering maintenance costs over the long term.

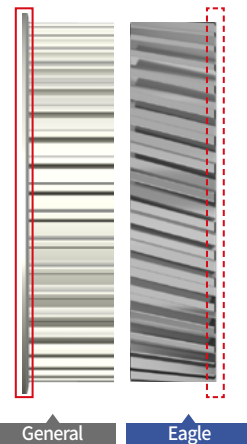
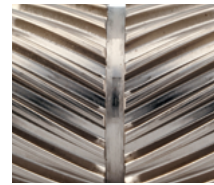

## EAGLE TIMING PULLEY – How to order

- All 'EAGLE TIMING PULLEY' products are custom-manufactured according to customer specifications to suit various environments and requirements.
- Please be sure to discuss the specifications with us before placing an order.
- Please send the product information and drawings to our sales team for review, and we'll provide further guidance.



## Cautions

The helical offset design features a V-shaped arrangement, showing the direction. If the pulley has an asymmetrical shape, the drawing must specify the tooth direction.

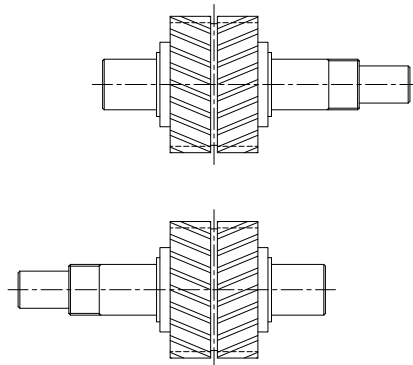

# TIMING PULLEY OVERVIEW

## Product Features

- High Accuracy** — Timing Pulley has minimized backlash and it leads to high accuracy.
- High Torque** — The unique structure of Timing Pulley (teeth) lessens slip possibility and makes it suitable for higher torque applications.
- High Speed Rotation** — Designed to be used with higher RPM applications since it rarely has vibration and noise issue.

## TIMING PULLEY – Tolerance

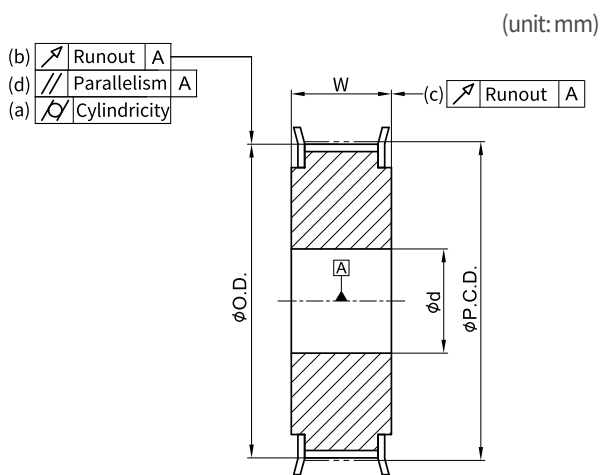

### Tolerance of Outer Diameter

Outer Diameter(OD)		Tolerance
greater than (>)	less than or equal to (≤)	
	25.4	0 ~ +0.05
25.4	50.8	0 ~ +0.08
50.8	101.6	0 ~ +0.10
101.6	117.8	0 ~ +0.13
117.8	304.8	0 ~ +0.15
304.8	508	0 ~ +0.18
508		0 ~ +0.20

### Runout: (b)

Outer Diameter (O.D.)		Tolerance
greater than (>)	less than or equal to (≤)	
	25.4	0.05
25.4	50.8	0.07
50.8	101.6	0.1
101.6	203.2	0.13
203.2		$0.13 + \{(O.D. - 203.2) \times 0.0005\}$

### Runout: (c)

Outer Diameter (O.D.)		Tolerance
greater than (>)	less than or equal to (≤)	
	25.4	0.05
25.4	50.8	0.08
50.8	101.6	0.1
101.6	254	O.D. X 0.001
254		$0.25 + \{(O.D. - 54.0) \times 0.0005\}$

### Cylindricity





Tooth Width (A)		Tolerance
greater than (>)	less than or equal to (≤)	
	20	0.02
20	40	0.04
40	80	0.08
80	120	0.12
120	160	0.16
160		$0.16 + \{(Tooth\ Width - 160) \times 0.001\}$

### Parallelism: (d)

Tooth Width (A)		Tolerance
greater than (>)	less than or equal to (≤)	
	20	0.02
20	40	0.03
40	80	0.04
80		0.05

# TIMING PULLEY OVERVIEW

## Clamping Methods

Shape	CODE	SPA□	A.P.LOCK
			<p>How to work</p> <p>By the taper-ring structure of A.P.Lock, when screws are fastened in a correct way, the inner surface shrinks inwards so it tightens the shaft. At the same time, the outer surface becomes expanding outwards so it clamps Timing Pulley tightly.</p>
			<p>Feature</p> <p>With high clamping force itself, it doesn't require any other complementary methods e.g. keyway. Self-centering function</p>
Shape	CODE	SPB	TAPER BUSHING
			<p>How to work</p> <p>By the taper-ring structure of Taper bushing, when screws are fastened in a correct way, the inner surface shrinks inwards so it tightens the shaft.</p>
			<p>Feature</p> <p>With high clamping force itself, it doesn't require any other complementary methods e.g. keyway. Easy and handy installation</p>
Shape	CODE	SC	SIDE-CLAMP
			<p>How to work</p> <p>Clamp with fastening screws in a vertical way to the shaft and make the hub's inner surface shrink inwards so it tightens the shaft.</p>
			<p>Feature</p> <p>Easy and handy installation</p>
Shape	CODE	ID□□	IDLER
			<p>Feature</p> <p>The inner diameter of the timing pulley has an inserted ball bearing, which is used for adjusting the tension of the timing belt, changing direction, or functioning as the driven pulley.</p>

## Installation Guide

### HOW TO INSTALL (SPA□, SPB)

- Wipe inner surface of shaft and hub to remove dust and oil.
- Wipe inner and outer surface of A.P.Lock or Taper Bushing.
- Spread anti-wear hydraulic oil or grease on to all inner surfaces.
  - A.P. Lock which is made of aluminum alloy does not require any anti-wear hydraulic oil.
  - Any oil type which includes molybdenumsulfur compounds or silicone is prohibited.
- Interlock A.P.Lock/Taper bushing with Timing Pulley and shaft respectively. (Do not fasten screws when the shaft is not inserted due to deformation.)
- After positioning, fasten the screws as stated following.
  - Fasten the screws with identical torque (1/8 of fastening torque) using torque wrench.
  - Make sure you fasten the screws in sequential order as shown on the right figure.
  - Repeat fastening the screws with 1/4 of fastening torque. (in diagonal order)
  - Repeat fastening the screws with 1/2 of fastening torque. (in diagonal order)

- Finally fasten the screws with full fastening torque.
- Repeat fastening until screws don't rotate any longer.

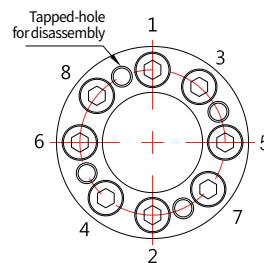

### HOW TO DISASSEMBLE (SPA□, SPB)

- Remove external load (torque/thrust) on the shaft and Timing Pulley.
- Remove self-load of belt etc.
- Unfasten all screws in the same order when they were fastened.
- In case A.P. Lock or Taper bushing is not detached properly, try to disassemble using the tapped-hole for disassembly.

# TIMING PULLEY OVERVIEW

## Additional Information about Clamping Methods

### (1) A.P.LOCK

Material	Steel	Please refer to "Dimensions / Performance" pages of SAPL-A Series (A.P.Lock) in this catalogue for more details.
	High Strength Aluminum Alloy	Please refer to "Dimensions / Performance" pages of SAPC Series (A.P.Lock) in this catalogue for more details.

### (2) TAPER BUSHING

#### TAPER BUSHING - I TYPE

Size(mm)							Max. Permissible Torque (N·m)	Max. Permissible Thrust Load (kN)	Screw (Locking bolt)	
d	D	D1	D2	d1	L	L1			Size	Fastening Torque (N·m)
6	22.5	16	8.5	3.3	10.5	3	5.6	1.87	M3×10	1.9
8	24.5	18	10.5	3.3	10.5	3	8.5	2.12	M3×10	1.9
10	29	21	12.75	4.4	13	4	18	3.59	M4×12	3.9
11	30	22	13.75	4.4	13	4	20	3.63	M4×12	3.9
12	31	23	14.75	4.4	13	4	23	3.76	M4×12	3.9
14	36	26	17.65	4.4	17	5	37	5.21	M4×18	3.9
15	37	27	18.65	4.4	17	5	39	5.1	M4×18	3.9
16	38	28	19.65	4.4	17	5	42	5.17	M4×18	3.9
17	39	29	20.65	4.4	17	5	45	5.23	M4×18	3.9
18	40	30	21.85	4.4	17	5	48	5.28	M4×18	3.9
19	42	32	22.85	4.4	17	5	49	5.12	M4×18	3.9
20	46	36	24.1	5.5	19	6	97	9.68	M5×18	7.8
22	47	37	25.75	5.5	19	6	110	9.98	M5×18	7.8
24	49	39	27.75	5.5	19	6	121	10	M5×18	7.8
25	51	41	28.75	5.5	19	6	124	9.9	M5×18	7.8
28	53	43	31.75	5.5	19	6	141	10	M5×18	7.8
30	56	46	33.75	5.5	19	6	149	9.89	M5×18	7.8
32	58	47	35.75	5.5	19	6	163	10.12	M5×18	7.8
35	61	50	39.1	5.5	20	6	173	9.88	M5×18	7.8

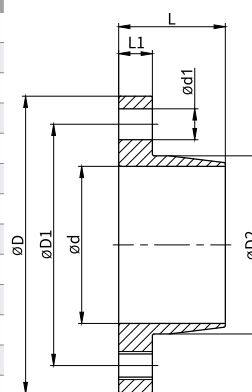

#### TAPER BUSHING - O TYPE

Size(mm)							Max. Permissible Torque (N·m)	Max. Permissible Thrust Load (kN)	Screw (Locking bolt)	
d	D	D1	D2	d1	L	L1			Size	Fastening Torque (N·m)
8	25.5	19	10	3.3	15.5	4	16	4	M3×12	2
10	30	22	12	4.5	16.5	5	39	5.34	M4×16	4
11	31	23	13	4.5	16.5	5	43	5.34	M4×16	4
12	32	24	14	4.5	16.5	5	48	5.34	M4×16	4
14	35	27	16.6	4.5	22	6	73	5.34	M4×18	4
15	36	28	17.6	4.5	22	6	78	5.34	M4×18	4
16	37	29	18.6	4.5	23	7	83	5.34	M4×18	4
17	38	30	19.6	4.5	23	7	88	5.34	M4×18	4
18	43	33	20.6	5.5	23	7	154	8.74	M5×20	8.3
19	45	35	22.4	5.5	23	7	163	8.74	M5×20	8.3
20	46	36	23.4	5.5	23	7	171	8.74	M5×20	8.3
22	48	38	24.6	5.5	23	7	186	8.74	M5×20	8.3
24	50	40	26.6	5.5	23	7	206	8.74	M5×20	8.3
25	52	42	28.4	5.5	23	7	216	8.74	M5×20	8.3
28	54	44	30.6	5.5	24	8	353	8.74	M5×25	8.3
30	57	47	33.4	5.5	24	8	382	8.74	M5×25	8.3
32	59	49	34.7	5.5	25	9	412	8.74	M5×25	8.3
35	63	53	38.4	5.5	26.5	9	451	8.74	M5×25	8.3

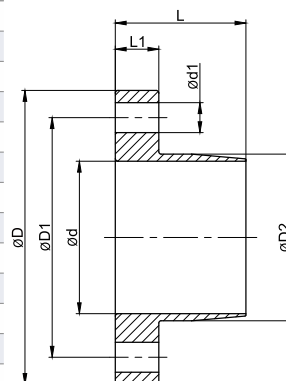

# TIMING PULLEY OVERVIEW

## Additional Information about Clamping Methods (··cont.)

### (3) SIDE-CLAMP (Standard Keyway Information)

Shaft(Bore) Diameter Ød	Keyway Dimension				t(mm)		Nominal Size (b x h)
	Mark Size	No Mark Tol. (E9)	H Tol. (H9)	J Tol. (Js9)	Size	Tolerance	
Ø6(over) ~ Ø8	2	+0.039	+0.025	±0.0125	1	+0.1 0	2×2
Ø8 ~ Ø10	3	+0.014	0		1.4		3×3
Ø10 ~ Ø12	4	+0.05	+0.03	±0.015	1.8		4×4
Ø12 ~ Ø17	5	+0.02	0		2.3		5×5
Ø17 ~ Ø22	6				2.8	+0.2 0	6×6
Ø22 ~ Ø30	8	+0.061	+0.036	±0.018	3.3		8×7
Ø30 ~ Ø38	10	+0.025	0				10×8
Ø38 ~ Ø44	12						12×8
Ø44 ~ Ø50	14	+0.075	+0.043	±0.0215	3.8	+0.2 0	14×9
Ø50 ~ Ø58	16	+0.032	0		4.3		16×10
Ø58 ~ Ø65	18				4.4		18×11
Ø65 ~ Ø75	20	+0.092	+0.052	±0.026	4.9		20×12
Ø75 ~ Ø85	22	+0.04	0		5.4	22×14	

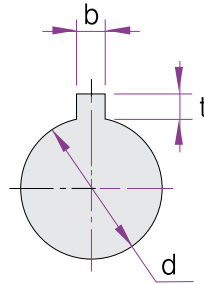

- The location of keyway on a coupling hub is determined by the standard product design of Sung-il Machinery. If you need a keyway in a different location, please discuss with our Customer Support team in advance.
- If you need to specify the length of keyway (axial direction) or tolerance for height and depth of keyway, please discuss with our Customer Support team in advance.
- Keyways can be processed on SC(Side-clamp) type only. (Not available on SPB, SPA types)

## Made-To-Order Process

Sung-il Machinery can conduct Made-To-Order processes (customization) for Timing Pulley upon our customers' requests.



### Various Materials/Surface Treatment Options

Material		Surface Treatment
High Strength Aluminum Alloy	AL20	White Anodizing Hard Anodizing Black Anodizing Electroless Nickel Plating
	AL60	
	AL70	
STEEL		Black Oxide Electroless Nickel Plating
Stainless Steel		Electro-polishing

### Various Tooth Profile Shapes

Trapezoidal	MXL, XL, L, H
	AT5, AT10, (D)T5, (D)T10
Curvilinear	1.5GT, 2GT, 3GT, 5GT, 8YU, 8MGT, 14MGT
	S2M, S3M, S5M, S8M, S14M
	P3M, P5M, P8M
	RPP5, RPP8
	MA3, MA5, MA8
	HTD5M, HTD8M, HTD14M

- ※ Please do not hesitate to contact us even for other Made-To-Order cases apart from the above categories.
- ※ Please make sure we discuss in advance prior to firm order placement.

## SATP-S3M SERIES



## High Strength Aluminum Alloy Timing Pulley

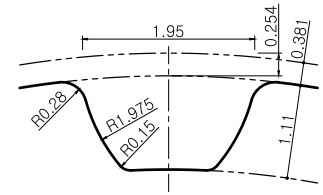

Tooth Profile: S3M / Pitch: 3mm

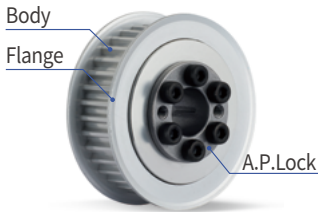

A.P.LOCK Type (SPA□)

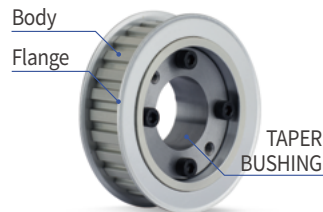

TAPER BUSHING Type (SPB)

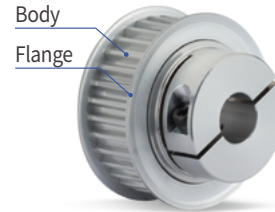

SIDE-CLAMP Type (SC)

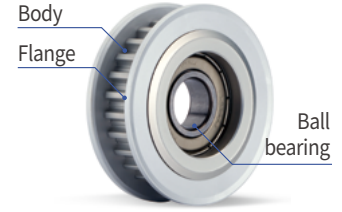

IDLER Type (ID□□)

## Structure and Material

Clamping methods		Category	Pulley (Body/Flange)	A.P.LOCK	TAPER BUSHING	Fastening Screw
SPA□	SPAA	Material	High Strength Aluminum Alloy	High Strength Aluminum Alloy	-	SCM435
		Surface Treatment	Anodizing (White/Hard)	Anodizing (Hard)	-	Electroless Nickel Plating
	SPAS	Material	High Strength Aluminum Alloy	Steel	-	SCM435
		Surface Treatment	Anodizing (White/Hard)	-	-	Black Oxide
SPB	Material	High Strength Aluminum Alloy	-	Steel	SCM435	
	Surface Treatment	Anodizing (White/Hard)	-	-	Black Oxide	
SC	Material	High Strength Aluminum Alloy	-	-	SCM435	
	Surface Treatment	Anodizing (White)	-	-	Black Oxide	
ID□□	IDOC IDTC IDTS	Material	High Strength Aluminum Alloy	-	-	-
		Surface Treatment	Anodizing (White/Hard)	-	-	-

## Standard Dimensions Range

Clamping Methods	OD (mm)	No. of Tooth (ea)	Belt Width (mm)
SPA□	SPAA	28.65 ~ 57.30	30 ~ 60
	SPAS	32.47 ~ 68.75	34 ~ 72
SPB	32.47 ~ 68.75	34 ~ 72	10, 15
SC	22.92 ~ 57.30	24 ~ 60	6, 10
ID□□	IDOC	28.65 ~ 57.30	30 ~ 60
	IDTC	38.20 ~ 47.75	40 ~ 50
	IDTS	28.65 ~ 57.30	30 ~ 60

## Clamping Methods

SPAA	A.P.Lock (High Strength Aluminum Alloy)	○	
SPAS	A.P.Lock (Steel)	○	
SPB	Taper Bushing	○	
SC	Side-clamp (High Strength Aluminum Alloy)	General	○
		With Keyway	○
IDOC	IDLER	Center bearing (1pc)	○
IDTC		Center bearing (2pcs)	○
IDTS		Both sides bearing (2pcs)	○

## How to Order

<b>SATP</b>	-	<b>S3M</b>	-	<b>NT□□</b>	-	<b>BW□□□</b>	-	<b>SPAA</b>	-	<b>□</b>	-	<b>12</b>	-	<b>HA</b>
Model		Tooth Profile		No. of Tooth		Belt Width		Clamping Methods		Shape		Inner Diameter (d)		Surface Treatment
① Clamping Methods		② Shape		③ Surface Treatment										
SPAA A.P.Lock (High Strength Aluminum Alloy)		I Flange part of A.P.Lock and Taper bushing is located inside		HA Hard Anodizing										
SPAS A.P.Lock (Steel)		O Flange part of A.P.Lock and Taper bushing is located outside		WA White Anodizing										
SPB Taper Bushing														
SC Side-clamp														
ID□□ IDLER Type														

※ For SC clamping type, only white anodizing (WA) surface treatment is available.

# SATP-S3M SERIES : SPAA

## High Strength Aluminum Alloy Timing Pulley

+ A.P.LOCK (High Strength Aluminum Alloy) Mounted Type

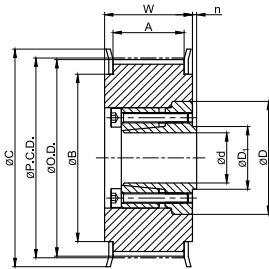

I TYPE

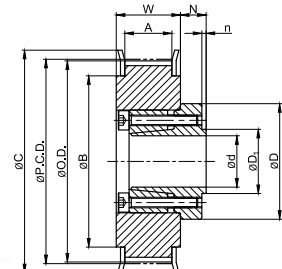

O TYPE

### Dimensions / Performance

TIMING PULLEY

(Unit:mm)

TYPE	NT	P.C.D.	O.D.	C	B	ID Range (I type)	ID Range (O type)
						BW150 (A:17, W:22)	BW100 (A:11, W:16)
SATP-S3M SPAA	30	28.65	27.89	32	23	-	6
	34	32.47	31.71	40	28	-	6, 8
	36	34.38	33.62	40	28	-	6, 8
	40	38.20	37.44	44	32	8	8, 10
	44	42.02	41.25	48	36	8 ~ 12	8 ~ 12
	48	45.84	45.07	50	38	8 ~ 14	8 ~ 12
	50	47.75	46.98	52	40	8 ~ 15	8 ~ 14
60	57.30	56.53	61	46	8 ~ 15	8 ~ 14	

• Please refer to the below table for more specific available ID(d) information.

A.P.LOCK

(Unit:mm)

Available ID (d)		6	8	10	12	14	15
Max. Permissible Torque (N·m)	I & O type	4	6	8	12	18	25
Max. Permissible Thrust Load (kN)	I & O type	1.33	1.51	1.63	1.99	2.56	3.34
D	I & O type	20	22	24	27	29	31
D <sub>1</sub>	I & O type	8.5	11	13	15	17	18.5
N / n	I & O type	4 / 0.5	5 / 0.5	5 / 0.5	6 / 1	6 / 1	7 / 1.2

- Keyway is **NOT** available for SPAA series.
- Surface treatment may not be applied on inner surface of Pulley's body.

### How to Order

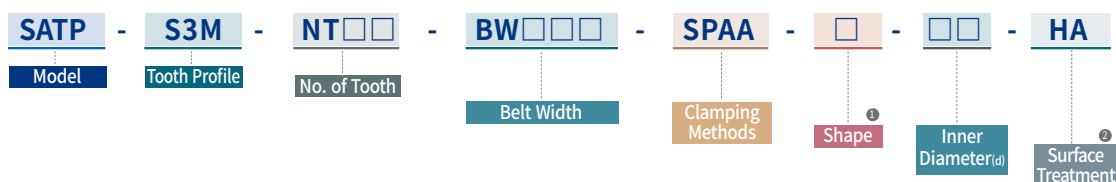

- ① Shape
- I Flange part of A.P.Lock and Taper bushing is located inside
  - O Flange part of A.P.Lock and Taper bushing is located outside

- ② Surface Treatment
- HA Hard Anodizing
  - WA White Anodizing

# SATP-S3M SERIES : SPAS

## High Strength Aluminum Alloy Timing Pulley

+ A.P.LOCK (Steel) Mounted Type

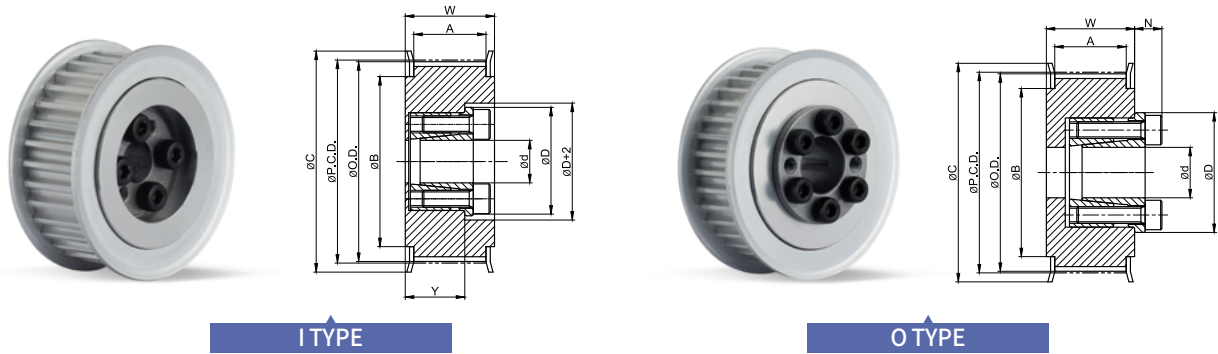

### Dimensions / Performance

#### TIMING PULLEY

(Unit:mm)

TYPE	NT	P.C.D.	O.D.	C	B	ID Range (I type)		ID Range (O type)	
						BW150 (A:17, W:22)	BW100 (A:11, W:16)	BW150 (A:17, W:22)	BW150 (A:17, W:22)
SATP-S3M SPAS	34	32.47	31.71	40	28	6	6	6	6
	36	34.38	33.62	40	28	6	6	6	6
	40	38.20	37.44	44	32	8	8	8	8
	44	42.02	41.25	48	36	8, 10	8, 10	8, 10	8, 10
	48	45.84	45.07	50	38	8, 10	8, 10	8, 10	8 ~ 12
	50	47.75	46.98	52	40	8, 10	8, 10	8, 10	8 ~ 14
	60	57.30	56.53	61	46	8, 10	8, 10	8, 10	8 ~ 17
72	68.75	67.99	74	58	8, 10	8, 10	8, 10	8 ~ 19	

- Please refer to the below table for more specific available ID(d) information.

#### A.P.LOCK

(Unit:mm)

Available ID (d)		6	8	10	12	14	15	16	17	18	19
Max. Permissible Torque (N·m)	I & O type	14	22	25	50	65	70	75	110	115	120
Max. Permissible Thrust Load (kN)	I & O type	4.7	5.6	5.6	8.4	9.5	9.5	9.5	12.6	12.6	12.6
D	I & O type	21.5	23.5	25.5	28.5	30.5	31.5	33	33.5	34.5	35.5
N	O type	6	6	6	6.5	6.5	6.5	6.5	6.5	6.5	6.5

- Keyway is **NOT** available for SPAS series.
- Surface treatment may not be applied on inner surface of Pulley's body.

### How to Order

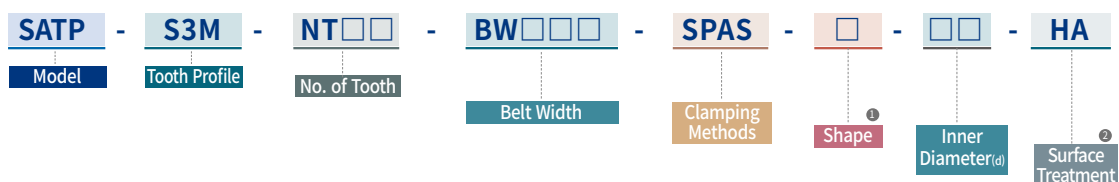

<sup>1</sup> Shape

- I Flange part of A.P.Lock and Taper bushing is located inside
- O Flange part of A.P.Lock and Taper bushing is located outside

<sup>2</sup> Surface Treatment

- HA Hard Anodizing
- WA White Anodizing

# SATP-S3M SERIES : SPB

## High Strength Aluminum Alloy Timing Pulley

+ Taper Bushing (Steel) Mounted Type

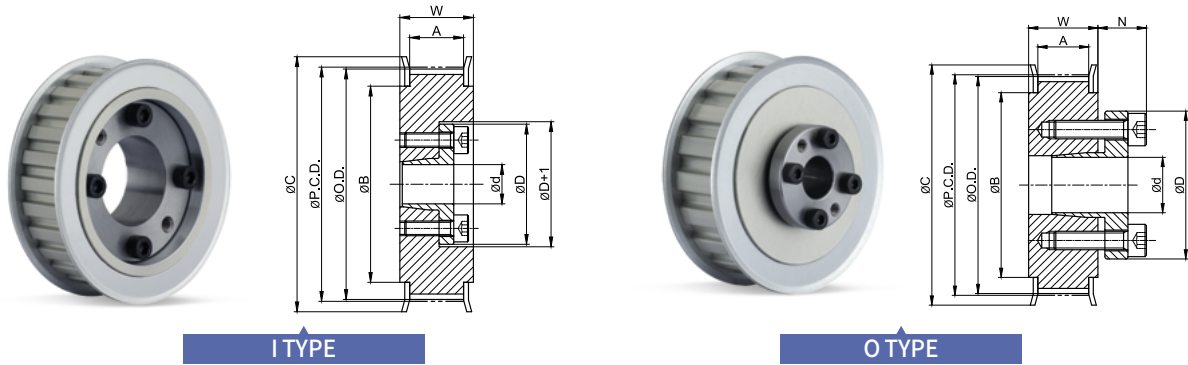

### Dimensions / Performance

**TIMING PULLEY**

(Unit:mm)

TYPE	NT	P.C.D.	O.D.	C	B	ID Range (I type)		ID Range (O type)	
						BW100 (A:11, W:16)	BW150 (A:17, W:22)	BW100 (A:11, W:16)	BW150 (A:17, W:22)
SATP-S3M SPB	34	32.47	31.71	40	28	6	6	8	8
	36	34.38	33.62	40	28	6	6	8	8
	40	38.2	37.44	44	32	8	8	8 ~ 11	8 ~ 11
	44	42.02	41.25	48	36	8	8 ~ 12	8 ~ 14	8 ~ 14
	48	45.84	45.07	50	38	8	8 ~ 12	8 ~ 16	8 ~ 16
	50	47.75	46.98	52	40	8	8 ~ 12	8 ~ 17	8 ~ 17
	60	57.30	56.53	61	46	8	8 ~ 12	8 ~ 19	8 ~ 19
72	68.75	67.99	74	58	8	8 ~ 12	8 ~ 25	8 ~ 25	

• Please refer to the below table for more specific available ID(d) information.

**TAPER BUSHING**

(Unit:mm)

Available ID (d)		6	8	10	11	12	14	15	16	17	18	19	20	22	24	25
Max. Permissible Torque (N·m)	I type	5.6	8.5	18	20	23										
	O type		16	39	43	48	73	78	83	88	154	163	171	186	206	216
Max. Permissible Thrust Load (kN)	I type	1.87	2.12	3.59	3.63	3.76										
	O type		4	5.34	5.34	5.34	5.34	5.34	5.34	5.34	8.74	8.74	8.74	8.74	8.74	8.74
D	I type	22.5	24.5	29	30	31										
	O type		25.5	30	31	32	35	36	37	38	43	45	46	48	50	52
N	O type		8.5	10.5	10.5	10.5	12	12	13	13	14	14	14	14	14	14

- Keyway is **NOT** available for SPB series.
- Surface treatment may not be applied on inner surface of Pulley's body.

### How to Order

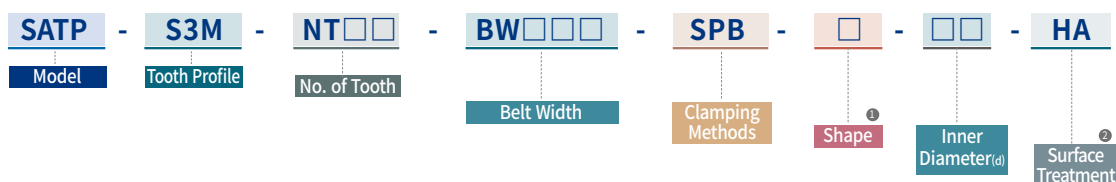

- ① Shape
- I Flange part of A.P.Lock and Taper bushing is located inside
  - O Flange part of A.P.Lock and Taper bushing is located outside

- ② Surface Treatment
- HA Hard Anodizing
  - WA White Anodizing

# SATP-S3M SERIES : SC

## High Strength Aluminum Alloy Timing Pulley

+ Side-clamp (High Strength Aluminum Alloy) Type

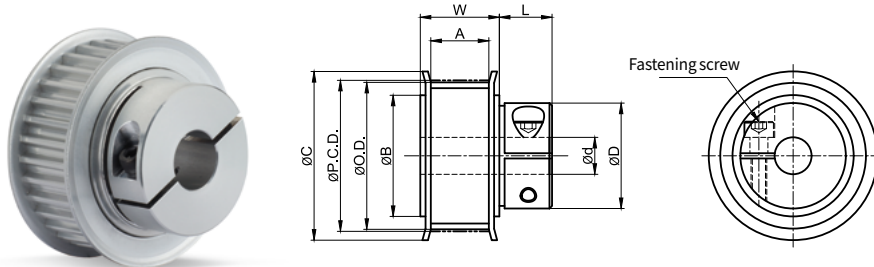

### Dimensions / Performance

#### TIMING PULLEY

(Unit:mm)

TYPE	NT	P.C.D.	O.D.	C	B	D	L	Fastening Screw		ID Range	
								Size	Fastening Torque(N·m)	BW060 (A:7, W:11)	BW100 (A:11, W:16)
SATP-S3M SC	24	22.92	22.16	25	16	13	9	M2X8	0.4	4	4
	26	24.83	24.07	28	18	13	9	M2X8	0.4	4	4
	28	26.74	25.98	30	20	13	9	M2X8	0.4	4	4
	30	28.65	27.89	32	23	20	9	M2X8	0.4	6, 8	6, 8
	32	30.56	29.80	35	25	20	9	M2X8	0.4	6, 8	6, 8
	36	34.38	33.62	40	28	26	12.5	M3X10	1.5	6, 8	6, 8
	40	38.20	37.44	44	32	26	12.5	M3X10	1.5	8, 10	8, 10
	44	42.02	41.25	48	36	31	14	M4X14	3.5	8, 10	8, 10
	48	45.84	45.07	50	38	33	14	M4X14	3.5	8 ~ 12	8 ~ 12
	50	47.75	46.98	52	40	36	14	M4X14	3.5	8 ~ 14	8 ~ 14
60	57.30	56.53	61	46	41	15.5	M5X16	6	8 ~ 16	8 ~ 16	

- Keyway is available for SC series.
- Surface treatment may not be applied on inner surface of Pulley's body.

### Slip Torque (N·m) by Inner diameters

ID Range (d)	4	6	8	10	11	12	13	14	15	16
Slip Torque (N·m)	0.16	0.95	2.6	2.6	2.6	2.6	2.6	7.6	7.6	7.6

- Keyway is available for SC series.
- Surface treatment may not be applied on inner surface of Pulley's body.

### How to Order

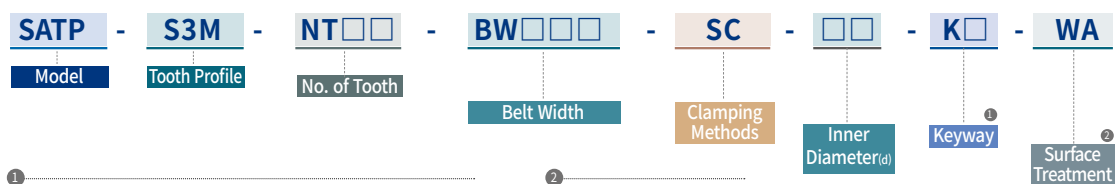

① Keyway  
 No mark No Keyway  
 K(b size) Keyway processed according to the indicated b size.

② Surface Treatment  
 WA White Anodizing

# SATP-S3M SERIES : IDOC, IDTC

High Strength Aluminum Alloy Timing Pulley

+ Bearing Mounted Type (Center bearing)

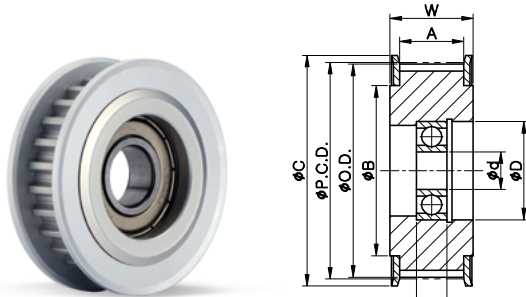

IDOC TYPE (Bearing 1 pc.)

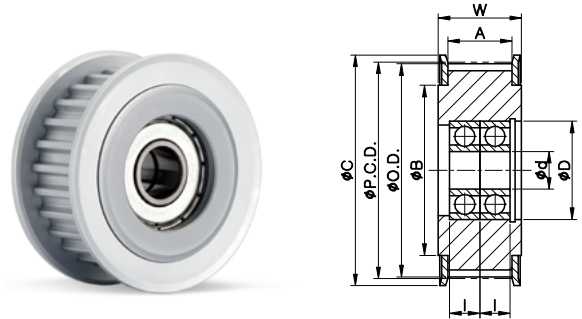

IDTC TYPE (Bearing 2 pcs.)

## Dimensions/Performance

TIMING PULLEY

(Unit:mm)

TYPE	NT	P.C.D.	O.D.	C	B	Bearing	D	I	ID (d)	ID (d)
									IDOC(1 pc)	IDTC(2 pcs)
SATP-S3M IDOC IDTC	30	28.65	27.89	32	23	626ZZ	19	6	6	-
	34	32.47	31.71	40	28	608ZZ	22	7	8	-
	36	34.38	33.62	40	28	608ZZ	22	7	8	-
	40	38.20	37.44	44	32	628ZZ	24	8	8	-
						6000ZZ	26	8	10	-
						6900ZZ	22	6	-	10
						6901ZZ	24	6	-	12
	44	42.02	41.25	48	36	628ZZ	24	8	8	-
						6000ZZ	26	8	10	-
						6900ZZ	22	6	-	10
						6001ZZ	28	8	12	-
	48	45.84	45.07	50	38	6000ZZ	26	8	10	-
						6900ZZ	22	6	-	10
	50	47.75	46.98	52	40	6000ZZ	26	8	10	-
						6900ZZ	22	6	-	10
						6001ZZ	28	8	12	-
						6901ZZ	24	6	-	12
	60	57.30	56.53	61	46	6000ZZ	26	8	10	-

## How to Order

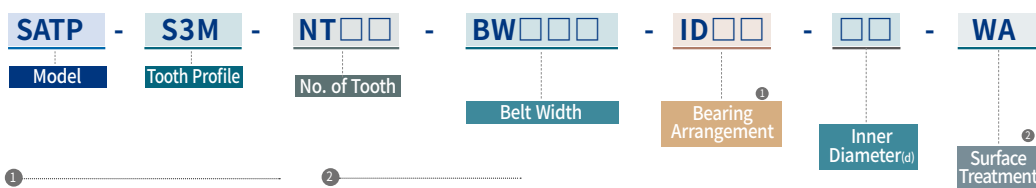

- ① Bearing Arrangement
- IDOC 1 pc, center
  - IDTC 2 pcs, center

- ② Surface Treatment
- HA Hard Anodizing
  - WA White Anodizing

# SATP-S3M SERIES : IDTS

## High Strength Aluminum Alloy Timing Pulley

+ Bearing Mounted Type (Both sides bearing)

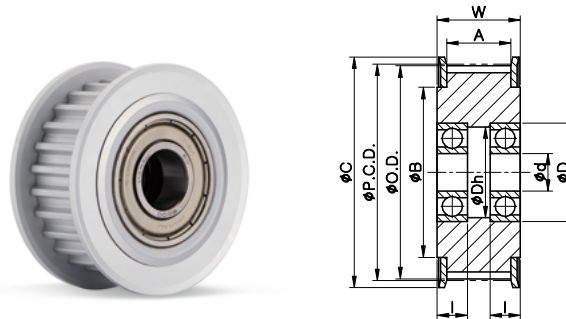

IDTS TYPE (Bearing 2 pcs.)

### Dimensions / Performance

#### TIMING PULLEY

(Unit:mm)

TYPE	NT	P.C.D.	O.D.	C	B	Bearing	D	Dh	l	ID (d) IDTS(2 pcs)	
										BW100 (A:11, W:16)	BW150 (A:17, W:22)
SATP-S3M IDTS	30	28.65	27.89	32	23	696ZZ	15	13	5	6	6
						688ZZ	16	14	5	8	-
	34	32.47	31.71	40	28	606ZZ	17	14.5	6	6	-
						608ZZ	22	19.5	7	-	8
						698ZZ	19	16.5	6	8	-
	36	34.38	33.62	40	28	606ZZ	17	14.5	6	6	-
						6900ZZ	22	19.5	6	10	10
	40	38.20	37.44	44	32	608ZZ	22	19.5	7	-	8
						698ZZ	19	16.5	6	8	-
						6900ZZ	22	19.5	6	10	10
						6001ZZ	28	25	8	-	12
						6901ZZ	24	22	6	12	-
	44	42.02	41.25	48	36	608ZZ	22	19.5	7	-	8
						6900ZZ	22	19.5	6	10	10
						6001ZZ	28	25	8	-	12
	48	45.84	45.07	50	38	6901ZZ	24	22	6	12	-
						6900ZZ	22	19.5	6	10	10
	50	47.75	46.98	52	40	6900ZZ	22	19.5	6	10	10
6001ZZ						28	25	8	-	12	
6901ZZ						24	22	6	12	-	
60	57.30	56.53	61	46	6900ZZ	22	19.5	6	10	-	
					6001ZZ	28	25	8	-	12	

### How to Order

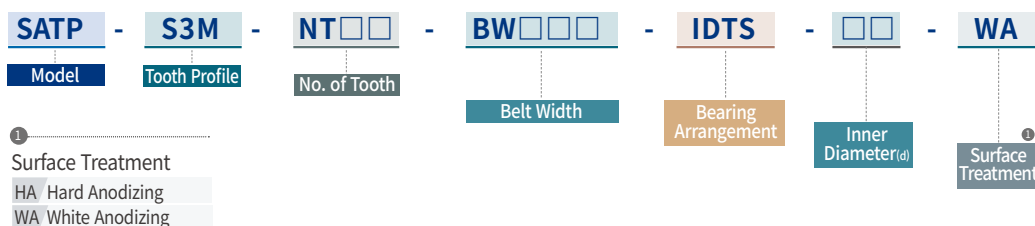

# SATP-S5M SERIES



## High Strength Aluminum Alloy Timing Pulley

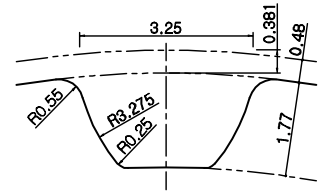

Tooth Profile: S5M / Pitch: 5mm

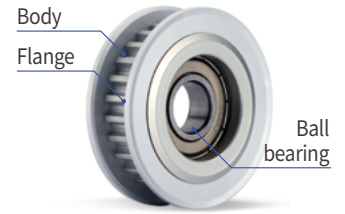
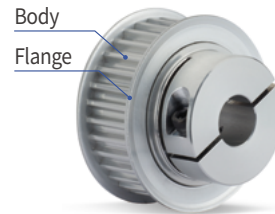
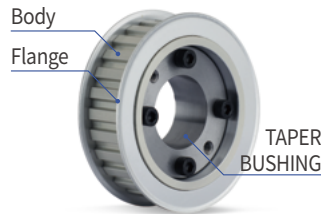
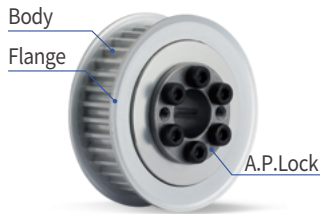

A.P.LOCK Type (SPA□)

TAPER BUSHING Type (SPB)

SIDE-CLAMP Type (SC)

IDLER Type (ID□□)

### Structure and Material

Clamping methods		Category	Pulley (Body/Flange)	A.P.LOCK	TAPER BUSHING	Fastening Screw
SPA□	SPAA	Material	High Strength Aluminum Alloy	High Strength Aluminum Alloy	-	SCM435
		Surface Treatment	Anodizing (White/Hard)	Anodizing (Hard)	-	Electroless Nickel Plating
	SPAS	Material	High Strength Aluminum Alloy	Steel	-	SCM435
		Surface Treatment	Anodizing (White/Hard)	-	-	Black Oxide
SPB	Material	High Strength Aluminum Alloy	-	Steel	SCM435	
	Surface Treatment	Anodizing (White/Hard)	-	-	Black Oxide	
SC	Material	High Strength Aluminum Alloy	-	-	SCM435	
	Surface Treatment	Anodizing (White)	-	-	Black Oxide	
ID□□	IDOC IDTC IDTS	Material	High Strength Aluminum Alloy	-	-	-
		Surface Treatment	Anodizing (White/Hard)	-	-	-

### Standard Dimensions Range

Clamping Methods	OD (mm)	No. of Tooth (ea)	Belt Width (mm)
SPA□	SPAA	31.83 ~ 63.66	20 ~ 40
	SPAS	38.20 ~ 114.59	24 ~ 72
SPB	35.01 ~ 114.59	22 ~ 72	10, 15, 25
SC	38.20 ~ 95.49	24 ~ 60	10, 15
ID□□	IDOC	31.83 ~ 70.03	20 ~ 44
	IDTC	31.83 ~ 70.03	20 ~ 44
	IDTS	31.83 ~ 70.03	20 ~ 44

### Clamping Methods

SPAA	A.P.Lock (High Strength Aluminum Alloy)	○	
SPAS	A.P.Lock (Steel)	○	
SPB	Taper Bushing	○	
SC	Side-clamp (High Strength Aluminum Alloy)	General	○
		With Keyway	○
IDOC	IDLER	Center bearing (1pc)	○
IDTC		Center bearing (2pcs)	○
IDTS		Both sides bearing (2pcs)	○

### How to Order

**SATP** - **S5M** - **NT□□** - **BW□□□** - **SPAA** - **□** - **12** - **HA**

Model      Tooth Profile      No. of Tooth      Belt Width      Clamping Methods      Shape      Inner Diameter (d)      Surface Treatment

1 Clamping Methods  
 SPAA A.P.Lock (High Strength Aluminum Alloy)  
 SPAS A.P.Lock (Steel)  
 SPB Taper Bushing  
 SC Side-clamp  
 ID□□ IDLER Type

2 Shape  
 I Flange part of A.P.Lock and Taper bushing is located inside  
 O Flange part of A.P.Lock and Taper bushing is located outside

3 Surface Treatment  
 HA Hard Anodizing  
 WA White Anodizing

※ For SC clamping type, only white anodizing (WA) surface treatment is available.

# SATP-S5M SERIES : SPAA

High Strength Aluminum Alloy Timing Pulley  
+ A.P.LOCK (High Strength Aluminum Alloy) Mounted Type

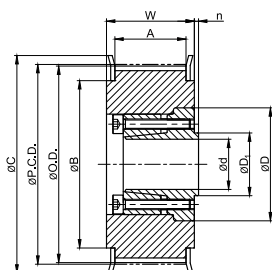

I TYPE

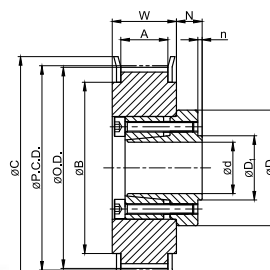

O TYPE

## Dimensions / Performance

### TIMING PULLEY

(Unit:mm)

TYPE	NT	P.C.D.	O.D.	C	B	ID Range (I type)	ID Range (O type)
						BW150 (A:17, W:22)	BW100 (A:11, W:16)
SATP-S5M SPAA	20	31.83	30.87	36	24	-	6
	22	35.01	34.05	40	27	-	8
	24	38.20	37.24	45	30	-	8, 10
	25	39.79	38.83	45	30	-	8, 10
	26	41.38	40.42	48	35	8, 10	8, 10
	28	44.56	43.60	48	35	8, 10	8, 10
	30	47.75	46.79	52	36	10, 12	10, 12
	32	50.93	49.97	55	40	10 ~ 15	10 ~ 15
	34	54.11	53.15	61	45	10 ~ 16	10 ~ 16
	36	57.30	56.34	61	45	10 ~ 16	10 ~ 16
40	63.66	62.70	67	50	10 ~ 16	10 ~ 16	

- Please refer to the below table for more specific available ID(d) information.

### A.P.LOCK

(Unit:mm)

Available ID (d)		6	8	10	12	14	15	16
Max. Permissible Torque (N·m)	I & O type	4	6	8	12	18	25	26
Max. Permissible Thrust Load (kN)	I & O type	1.33	1.51	1.63	1.99	2.56	3.34	3.34
D	I & O type	20	22	24	27	29	31	32
D <sub>1</sub>	I & O type	8.5	11	13	15	17	18.5	19.5
N / n	I & O type	4 / 0.5	5 / 0.5	5 / 0.5	6 / 1	6 / 1	7 / 1.2	7 / 1.2

- Keyway is **NOT** available for SPAA series.
- Surface treatment may not be applied on inner surface of Pulley's body.

## How to Order

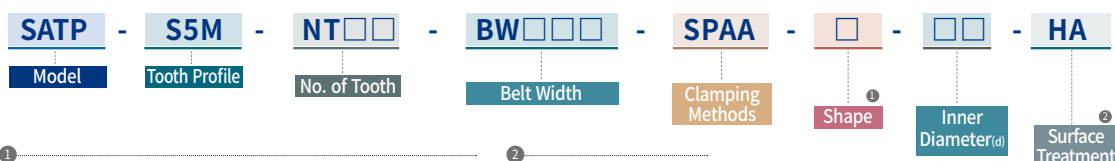

① Shape

- I Flange part of A.P.Lock and Taper bushing is located inside
- O Flange part of A.P.Lock and Taper bushing is located outside

② Surface Treatment

- HA Hard Anodizing
- WA White Anodizing

# SATP-S5M SERIES : SPAS

## High Strength Aluminum Alloy Timing Pulley

+ A.P.LOCK (Steel) Mounted Type

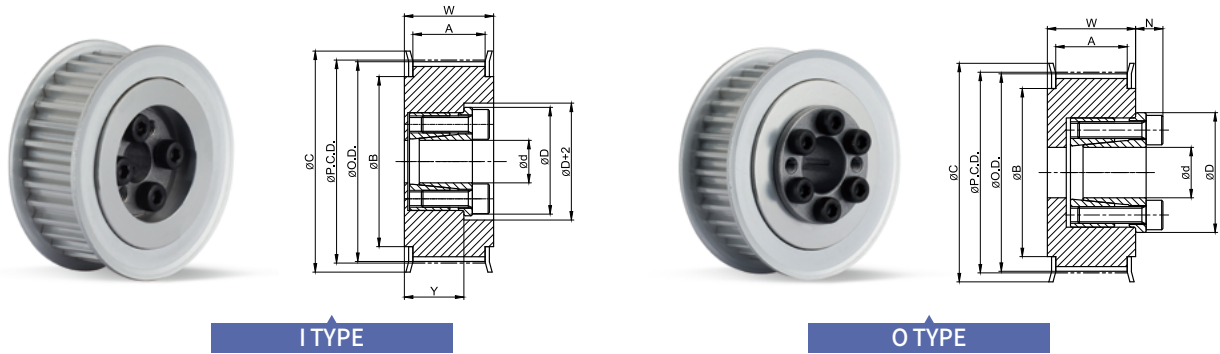

### Dimensions / Performance

**TIMING PULLEY**

(Unit:mm)

TYPE	NT	P.C.D.	O.D.	C	B	ID Range (I type)		ID Range (O type)		
						BW150 (A:17, W:22)	BW250 (A:27, W:32)	BW100 (A:11, W:16)	BW150 (A:17, W:22)	BW250 (A:27, W:32)
SATP-S5M SPAS	24	38.20	37.24	45	30	8	8	8	8	8
	25	39.79	38.83	45	30	8	8	8	8	8
	26	41.38	40.42	48	35	8, 10	8, 10	8, 10	8, 10	8, 10
	28	44.56	43.60	48	35	8, 10	8, 10	8, 10	8, 10	8, 10
	30	47.75	46.79	52	36	10	10	10	10	10
	32	50.93	49.97	55	40	10	10 ~ 14	10 ~ 14	10 ~ 14	10 ~ 14
	34	54.11	53.15	61	45	10	10 ~ 16	10 ~ 14	10 ~ 16	10 ~ 16
	36	57.30	56.34	61	45	10	10 ~ 16	10 ~ 14	10 ~ 16	10 ~ 16
	40	63.66	62.70	67	50	10	10 ~ 19	10 ~ 14	10 ~ 19	10 ~ 19
	44	70.03	69.07	74	58	-	12 ~ 22	12, 14	12 ~ 22	12 ~ 22
	48	76.39	75.43	83	63	-	12 ~ 24	12, 14	12 ~ 22	12 ~ 24
	50	79.58	78.62	87	67	-	12 ~ 28	12, 14	12 ~ 22	12 ~ 28
	60	95.49	94.53	99	80	-	12 ~ 30	12, 14	12 ~ 22	12 ~ 30
	72	114.59	113.63	119	100	-	12 ~ 30	12, 14	12 ~ 22	12 ~ 35

• Please refer to the below table for more specific available ID(d) information.

**A.P.LOCK**

(Unit:mm)

Available ID (d)		8	10	12	14	15	16	17	18	19	20	22	24	25	28	30	32	35
Max. Permissible Torque (N·m)	I & O type	22	25	50	65	70	75	110	115	120	220	290	320	350	380	410	440	720
Max. Permissible Thrust Load (kN)	I & O type	5.6	5.6	8.4	9.5	9.5	9.5	12.6	12.6	12.6	21.6	26	26	27.2	27	27	27	41.1
D	I & O type	23.5	25.5	28.5	30.5	31.5	33	33.5	34.5	35.5	42	44	46	47	50	52	54	62
N	O type	6	6	6.5	6.5	6.5	6.5	6.5	6.5	6.5	8	8	8	8	8.5	8.5	8.5	10

- Keyway is **NOT** available for SPAS series.
- Surface treatment may not be applied on inner surface of Pulley's body.

### How to Order

**SATP** - **S5M** - **NT**□□ - **BW**□□□ - **SPAS** - □ - □□ - **HA**

Model      Tooth Profile      No. of Tooth      Belt Width      Clamping Methods      Shape      Inner Diameter<sub>(d)</sub>      Surface Treatment

① Shape  
 I Flange part of A.P.Lock and Taper bushing is located inside  
 O Flange part of A.P.Lock and Taper bushing is located outside

② Surface Treatment  
 HA Hard Anodizing  
 WA White Anodizing

# SATP-S5M SERIES : SPB

## High Strength Aluminum Alloy Timing Pulley

+ Taper Bushing (Steel) Mounted Type

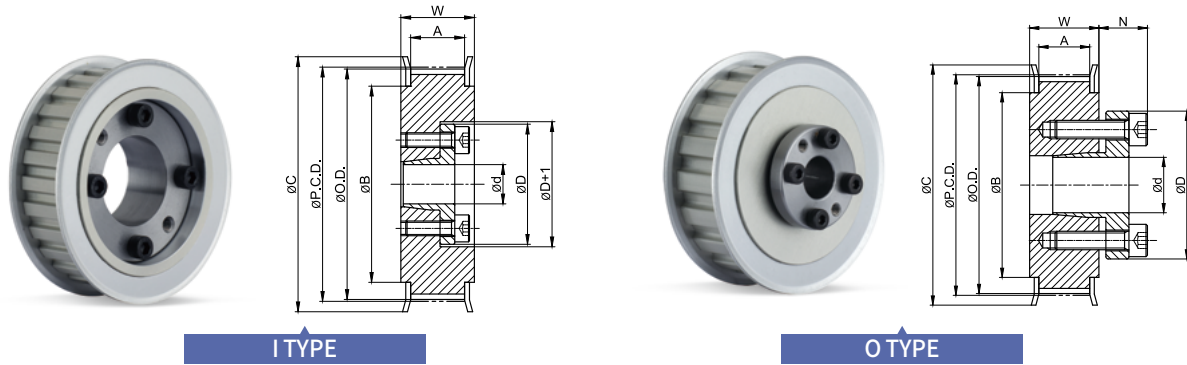

### Dimensions / Performance

#### TIMING PULLEY

(Unit:mm)

TYPE	NT	P.C.D.	O.D.	C	B	ID Range (I type)			ID Range (O type)		
						BW100 (A:11, W:16)	BW150 (A:17, W:22)	BW250 (A:27, W:32)	BW100 (A:11, W:16)	BW150 (A:17, W:22)	BW250 (A:27, W:32)
SATP-S5M SPB	22	35.01	34.05	40	27	-	-	-	8	-	-
	24	38.20	37.24	45	30	8	8	8	8 ~ 10	10	10
	25	39.79	38.83	45	30	8	8	8	8 ~ 10	10	10
	26	41.38	40.42	48	35	8	8 ~ 12	8 ~ 12	8 ~ 12	10 ~ 12	10 ~ 12
	28	44.56	43.60	48	35	8	8 ~ 12	8 ~ 12	8 ~ 12	10 ~ 12	10 ~ 12
	30	47.75	46.79	52	36	-	10 ~ 12	10 ~ 12	10 ~ 15	10 ~ 15	10 ~ 15
	32	50.93	49.97	55	40	-	10 ~ 12	10 ~ 12	10 ~ 17	10 ~ 17	10 ~ 17
	34	54.11	53.15	61	45	-	10 ~ 12	10 ~ 17	10 ~ 17	10 ~ 17	10 ~ 17
	36	57.30	56.34	61	45	-	10 ~ 12	10 ~ 17	10 ~ 17	10 ~ 17	10 ~ 17
	40	63.66	62.70	67	50	-	10 ~ 12	10 ~ 17	10 ~ 17	10 ~ 17	10 ~ 17
	44	70.03	69.07	74	58	-	12	12 ~ 25	12 ~ 25	12 ~ 25	12 ~ 25
	48	76.39	75.43	83	63	-	12	12 ~ 28	12 ~ 28	12 ~ 28	12 ~ 28
	50	79.58	78.62	87	67	-	12	12 ~ 32	12 ~ 32	12 ~ 32	12 ~ 32
	60	95.49	94.53	99	80	-	12	12 ~ 35	12 ~ 35	12 ~ 35	12 ~ 35
72	114.59	113.63	119	100	-	12	12 ~ 35	12 ~ 35	12 ~ 35	12 ~ 35	

- Please refer to the below table for more specific available ID(d) information.

#### TAPER BUSHING

(Unit:mm)

Available ID (d)	8	10	11	12	14	15	16	17	18	19	20	22	24	25	28	30	32	35
Max. Permissible Torque (N·m)	I type 8.5	18	20	23	37	39	42	45	48	49	97	110	121	124	141	149	163	173
	O type 16	39	43	48	73	78	83	88	154	163	171	186	206	216	353	382	412	451
Max. Permissible Thrust Load (kN)	I type 2.12	3.59	3.63	3.76	5.21	5.1	5.17	5.23	5.28	5.12	9.68	9.98	10	9.9	10	9.89	10.12	9.88
	O type 5.34	5.34	5.34	5.34	5.34	5.34	5.34	5.34	8.74	8.74	8.74	8.74	8.74	8.74	8.74	8.74	8.74	8.74
D	I type 24.5	29	30	31	36	37	38	39	40	42	46	47	49	51	53	56	58	61
	O type 25.5	30	31	32	35	36	37	38	43	45	46	48	50	52	54	57	59	63
N	O type 8.5	10.5	10.5	10.5	12	12	13	13	14	14	14	14	14	14	15.5	15.5	16.5	16.5

- Keyway is **NOT** available for SPB series.
- Surface treatment may not be applied on inner surface of Pulley's body.

### How to Order

**SATP** - **S5M** - **NT**□□ - **BW**□□□□ - **SPB** - □ - □□ - **HA**

Model      Tooth Profile      No. of Tooth      Belt Width      Clamping Methods      Shape      Inner Diameter (d)      Surface Treatment

① Shape  
 I Flange part of A.P.Lock and Taper bushing is located inside  
 O Flange part of A.P.Lock and Taper bushing is located outside

② Surface Treatment  
 HA Hard Anodizing  
 WA White Anodizing

# SATP-S5M SERIES : SC

## High Strength Aluminum Alloy Timing Pulley

+ Side-clamp (High Strength Aluminum Alloy) Type

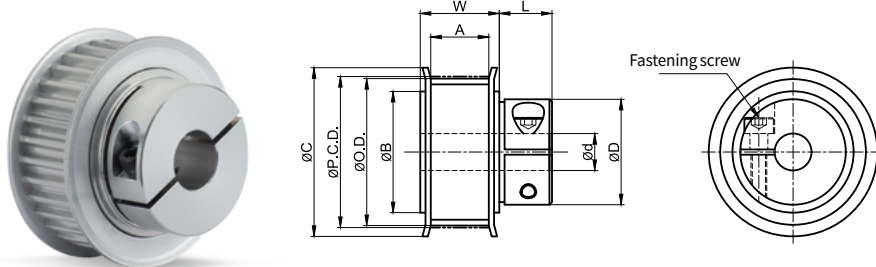

### Dimensions / Performance

#### TIMING PULLEY

(Unit:mm)

TYPE	NT	P.C.D.	O.D.	C	B	D	L	Fastening Screw		ID Range	
								Size	Fastening Torque(N·m)	BW100 (A:11, W:16)	BW150 (A:17, W:22)
SATP-S5M SC	24	38.20	37.24	45	30	26	12.5	M3X10	1.5	8, 10	8, 10
	25	39.79	38.83	45	30	26	12.5	M3X10	1.5	8, 10	8, 10
	26	41.38	40.42	48	35	31	14	M4X14	3.5	8, 10	8, 10
	28	44.56	43.60	48	35	31	14	M4X14	3.5	8, 10	8, 10
	30	47.75	46.79	52	36	31	14	M4X14	3.5	10	10
	32	50.93	49.97	55	40	36	14	M4X14	3.5	10 ~ 14	10 ~ 14
	34	54.11	53.15	61	45	41	15.5	M5X16	6	10 ~ 16	10 ~ 16
	36	57.30	56.34	61	45	41	15.5	M5X16	6	10 ~ 16	10 ~ 16
	40	63.66	62.70	67	50	46	15.5	M5X16	6	10 ~ 19	10 ~ 19
	44	70.03	69.07	74	58	46	15.5	M5X16	6	12 ~ 19	12 ~ 19
						55	16.5	M6X20	12	20 ~ 24	20 ~ 24
	48	76.39	75.43	83	63	46	15.5	M5X16	6	12 ~ 19	12 ~ 19
						55	16.5	M6X20	12	20 ~ 25	20 ~ 25
	50	79.58	78.62	87	67	46	15.5	M5X16	6	12 ~ 19	12 ~ 19
						55	16.5	M6X20	12	20 ~ 25	20 ~ 25
	60	95.49	94.53	99	80	46	15.5	M5X16	6	12 ~ 19	12 ~ 19
55						16.5	M6X20	12	20 ~ 25	20 ~ 25	

- Keyway is available for SC series.
- Surface treatment may not be applied on inner surface of Pulley's body.

### Slip Torque (N·m) by Inner diameters

ID Range (d)	8	10	11	12	13	14	15	16	17	18	19	20	21	22	23	24	25
Slip Torque (N·m)	2.6	2.6	2.6	2.6	2.6	7.6	7.6	7.6	7.6	7.6	7.6	48	48	66	66	95	95

### How to Order

**SATP** - **S5M** - **NT**□□ - **BW**□□□ - **SC** - □□ - **K**□ - **WA**

Model      Tooth Profile      No. of Tooth      Belt Width      Clamping Methods      Inner Diameter (d)      Keyway<sup>①</sup>      Surface Treatment<sup>②</sup>

<sup>①</sup> Keyway  
 No mark No Keyway  
 K(b size) Keyway processed according to the indicated b size.

<sup>②</sup> Surface Treatment  
 WA White Anodizing

# SATP-S5M SERIES : IDOC, IDTC

## High Strength Aluminum Alloy Timing Pulley

+ Bearing Mounted Type (Center bearing)

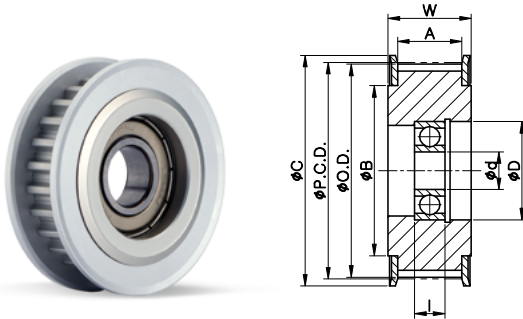

IDOC TYPE (Bearing 1 pc.)

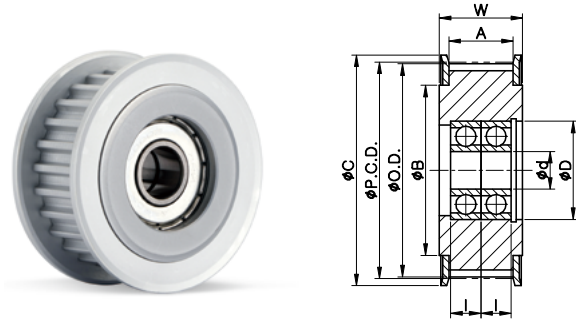

IDTC TYPE (Bearing 2 pcs.)

### Dimensions/Performance

#### TIMING PULLEY

(Unit:mm)

TYPE	NT	P.C.D.	O.D.	C	B	Bearing	D	I	ID (d)		ID (d)		
									IDOC(1 pc)		IDTC(2 pcs)		
									BW100 (A:11, W:16)	BW150 (A:17, W:22)	BW150 (A:17, W:22)	BW250 (A:27, W:32)	
SATP-S5M IDOC IDTC	20	31.83	30.87	36	24	698ZZ	19	6	8	-	8	-	
	22	35.01	34.05	40	27	628ZZ	24	8	8	-	8	-	
	24	38.20	37.24	45	30	628ZZ	24	8	-	-	-	8	-
						6000ZZ	26	8	10	-	10	-	
						6901ZZ	24	6	-	-	12	-	
	25	39.79	38.83	45	30	6000ZZ	26	8	10	-	-	10	-
						6901ZZ	24	6	-	-	12	-	
						6000ZZ	26	8	-	-	10	-	
	26	41.38	40.42	48	35	6200ZZ	30	9	10	-	-	-	-
						6001ZZ	28	8	12	-	12	-	
						6902ZZ	28	7	15	-	15	-	
						6200ZZ	30	9	10	10	-	10	
						6001ZZ	28	8	12	-	-	-	
	28	44.56	43.60	48	35	6201ZZ	32	10	-	-	-	-	12
						6002ZZ	32	9	-	-	-	15	
						6902ZZ	28	7	15	-	-	-	
						6000ZZ	26	8	-	-	10	-	
						6200ZZ	30	9	10	-	-	-	
	30	47.75	46.79	52	36	6201ZZ	32	10	12	12	-	-	12
						6002ZZ	32	9	15	-	-	15	
						6000ZZ	26	8	10	-	-	10	
						6200ZZ	30	9	10	-	-	-	
						6201ZZ	32	10	12	-	-	-	
	32	50.93	49.97	55	40	6000ZZ	26	8	10	-	-	10	-
						6201ZZ	32	10	12	-	-	12	
						6002ZZ	32	9	15	-	-	-	
						6200ZZ	30	9	10	-	-	-	
						6001ZZ	28	8	-	-	12	-	
	36	57.30	56.34	61	45	6201ZZ	32	10	12	-	-	-	12
						6002ZZ	32	9	15	-	-	-	
						6202ZZ	35	11	-	15	-	15	
						6000ZZ	26	8	-	-	10	-	
6200ZZ						30	9	10	-	-	-		
40	63.66	62.70	67	50	6001ZZ	28	8	-	-	12	-	-	
					6201ZZ	32	10	12	-	-	12		
					6002ZZ	32	9	15	-	-	-		
					6202ZZ	35	11	-	-	-	15		
					6004ZZ	42	12	-	-	-	20		
44	70.03	69.07	74	58	6204ZZ	47	14	-	20	-	-		

### How to Order

<b>SATP</b>	-	<b>S5M</b>	-	<b>NT</b> □□	-	<b>BW</b> □□□□	-	<b>ID</b> □□	-	□□	-	<b>WA</b>	
Model		Tooth Profile		No. of Tooth		Belt Width		Bearing Arrangement		Inner Diameter (d)		Surface Treatment	
① Bearing Arrangement		② Surface Treatment											
IDOC / 1 pc, center		HA / Hard Anodizing											
IDTC / 2 pcs, center		WA / White Anodizing											

# SATP-S5M SERIES : IDTS

High Strength Aluminum Alloy Timing Pulley

+ Bearing Mounted Type (Both sides bearing)

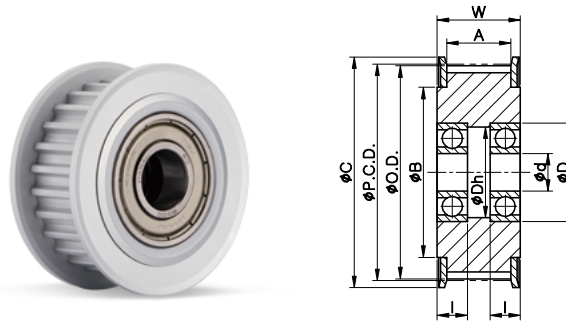

IDTS TYPE (Bearing 2 pcs.)

## Dimensions/Performance

TIMING PULLEY

(Unit:mm)

TYPE	NT	P.C.D.	O.D.	C	B	Bearing	D	Dh	l	ID (d) IDTS(2 pcs)		
										BW100 (A:11, W:16)	BW150 (A:17, W:22)	BW250 (A:27, W:32)
SATP-S5M IDTS  < Continued on next page >	20	31.83	30.87	36	24	698ZZ	19	16.5	6	8	8	8
						608ZZ	22	19.5	7	-	8	8
	22	35.01	34.05	40	27	698ZZ	19	16.5	6	8	-	-
						6900ZZ	22	19.5	6	10	-	-
	24	38.20	37.24	45	30	608ZZ	22	19.5	7	-	8	8
						6900ZZ	22	19.5	6	10	-	-
						6901ZZ	24	22	6	12	12	-
	25	39.79	38.83	45	30	606ZZ	17	14.5	6	-	-	6
						696ZZ	15	13	5	6	6	-
						608ZZ	22	19.5	7	-	-	8
						698ZZ	19	16.5	6	8	8	-
						6900ZZ	22	19.5	6	10	-	-
						6901ZZ	24	22	6	12	12	-
	26	41.38	40.42	48	35	6200ZZ	30	25	9	-	10	10
						6900ZZ	22	19.5	6	10	-	-
						6001ZZ	28	25	8	-	12	-
						6901ZZ	24	22	6	12	-	-
						6902ZZ	28	26	7	-	-	15
	28	44.56	43.60	48	35	6200ZZ	30	25	9	-	-	10
						6900ZZ	22	19.5	6	10	10	-
						6001ZZ	28	25	8	-	12	-
						6901ZZ	24	22	6	12	-	-
	30	47.75	46.79	52	36	6902ZZ	28	26	7	-	15	-
						6200ZZ	30	25	9	-	10	-
						6900ZZ	22	19.5	6	10	-	-
						6001ZZ	28	25	8	-	12	-
						6201ZZ	32	27	10	-	-	12
						6901ZZ	24	22	6	12	-	-
32	50.93	49.97	55	40	6902ZZ	28	26	7	-	15	-	
					6200ZZ	30	25	9	-	10	-	
					6001ZZ	28	25	8	-	12	-	
					6201ZZ	32	27	10	-	-	12	
					6804ZZ	32	29	7	-	20	20	

# SATP-S5M SERIES : IDTS

## High Strength Aluminum Alloy Timing Pulley

+ Bearing Mounted Type (Both sides bearing)

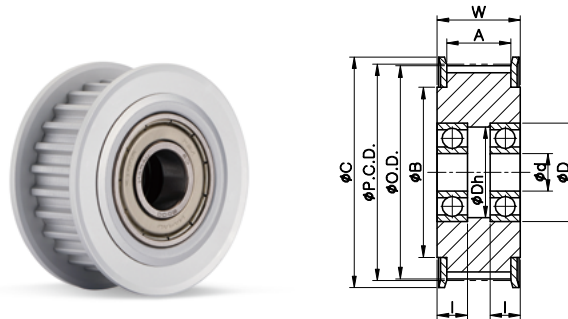

IDTS TYPE (Bearing 2 pcs.)

### Dimensions / Performance

#### TIMING PULLEY

(Unit:mm)

TYPE	NT	P.C.D.	O.D.	C	B	Bearing	D	Dh	l	ID (d) IDTS(2 pcs)		
										BW100 (A:11, W:16)	BW150 (A:17, W:22)	BW250 (A:27, W:32)
SATP-S5M IDTS	36	57.30	56.34	61	45	6200ZZ	30	25	9	-	10	-
						6002ZZ	32	29	9	-	15	-
						6202ZZ	35	30	11	-	-	15
						6904ZZ	37	34	9	-	20	20
	40	63.66	62.70	67	50	6200ZZ	30	25	9	-	10	-
						6002ZZ	32	29	9	-	15	-
						6202ZZ	35	30	11	-	-	15
						6904ZZ	37	34	9	-	20	20
	44	70.03	69.07	74	58	6904ZZ	37	34	9	-	20	20

### How to Order

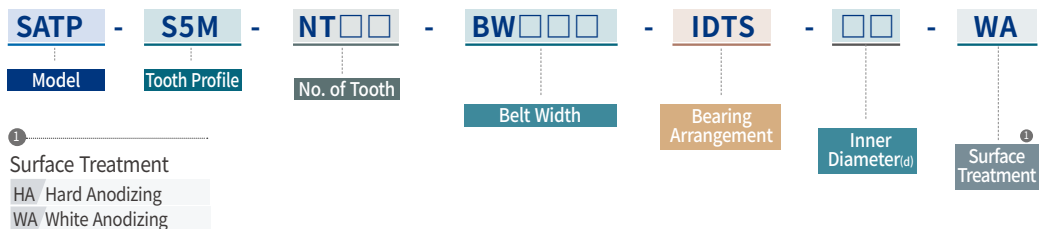

# SATP-S8M SERIES

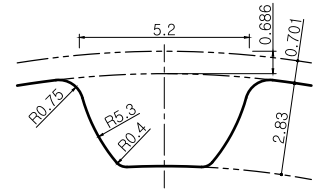

Tooth Profile: S8M / Pitch: 8mm

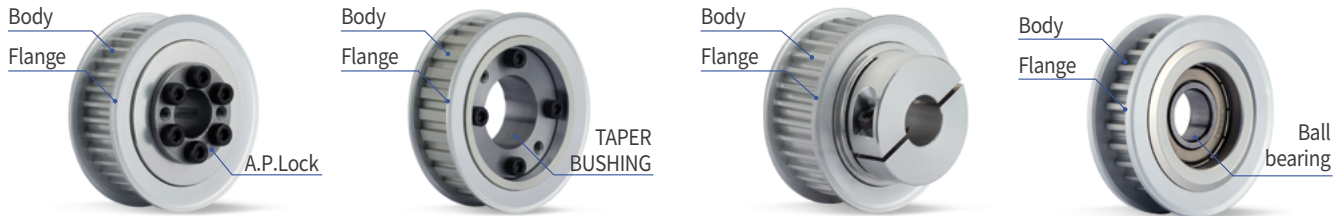

A.P.Lock Type (SPA□)

TAPER BUSHING Type (SPB)

SIDE-CLAMP Type (SC)

IDLER Type (ID□□)

## Structure and Material

Clamping methods		Category	Pulley (Body/Flange)	A.P. LOCK	TAPER BUSHING	Fastening Screw
SPAS	Material		High Strength Aluminum Alloy	Steel	-	SCM435
	Surface Treatment		Anodizing (White/Hard)	-	-	Black Oxide
SPB	Material		High Strength Aluminum Alloy	-	Steel	SCM435
	Surface Treatment		Anodizing (White/Hard)	-	-	Black Oxide
SC	Material		High Strength Aluminum Alloy	-	-	SCM435
	Surface Treatment		Anodizing (White)	-	-	Black Oxide
ID□□	IDOC	Material	High Strength Aluminum Alloy	-	-	-
	IDTC IDTS	Surface Treatment	Anodizing (White/Hard)	-	-	-

## Standard Dimensions Range

Clamping Methods	OD (mm)	No. of Tooth (ea)	Belt Width (mm)
SPAS	48.38 ~ 183.35	19 ~ 72	15, 25, 30, 40
SPB	45.84 ~ 152.79	18 ~ 60	15, 25, 30, 40
SC	50.93 ~ 91.67	20 ~ 36	15, 25
ID□□	IDOC	50.93 ~ 101.86	20 ~ 40
	IDTC	50.93 ~ 76.39	20 ~ 30
	IDTS	56.02 ~ 101.86	22 ~ 40

## Clamping Methods

SPAA	A.P.Lock (High Strength Aluminum Alloy)	X	
SPAS	A.P.Lock (Steel)	○	
SPB	Taper Bushing	○	
SC	Side-clamp (High Strength Aluminum Alloy)	General	○
		With Keyway	○
IDOC	IDLER	Center bearing (1pc)	○
IDTC		Center bearing (2pcs)	○
IDTS		Both sides bearing (2pcs)	○

## How to Order

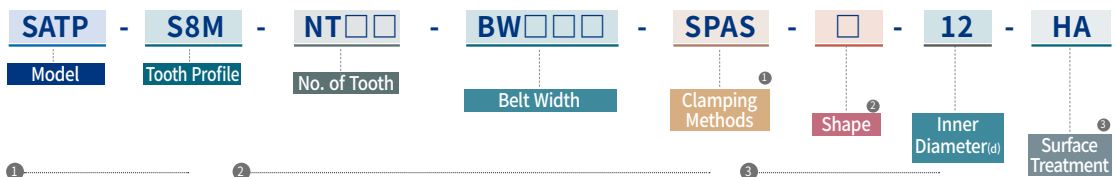

- ① Clamping Methods
- SPAS A.P.Lock (Steel)
  - SPB Taper Bushing
  - SC Side-clamp
  - ID□□ IDLER Type

- ② Shape
- I Flange part of A.P.Lock and Taper bushing is located inside
  - O Flange part of A.P.Lock and Taper bushing is located outside

- ③ Surface Treatment
- HA Hard Anodizing
  - WA White Anodizing

※ For SC clamping type, only white anodizing (WA) surface treatment is available.

# SATP-S8M SERIES : SPAS

## High Strength Aluminum Alloy Timing Pulley

+ A.P.LOCK (Steel) Mounted Type

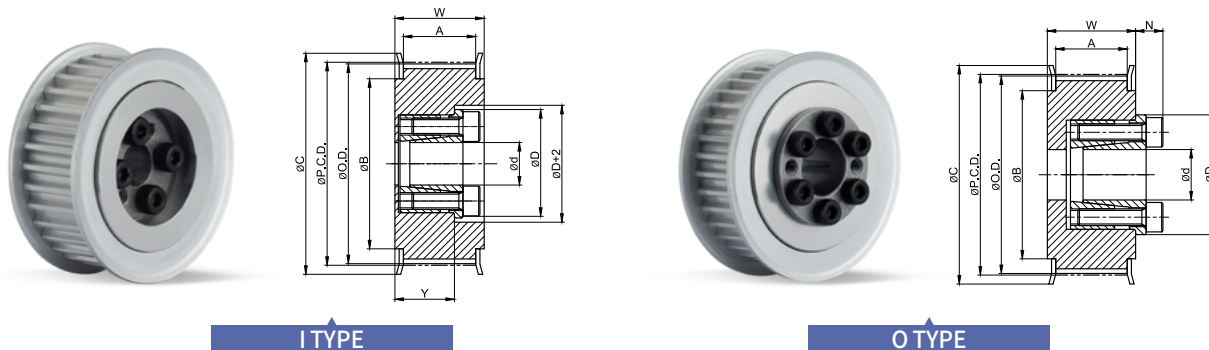

### Dimensions / Performance

#### TIMING PULLEY

(Unit:mm)

TYPE	NT	P.C.D.	O.D.	C	B	ID Range (I type)			ID Range (O type)			
						BW250 (A:28, W:33)	BW300 (A:33, W:38)	BW400 (A:44, W:49)	BW150 (A:17, W:22)	BW250 (A:28, W:33)	BW300 (A:33, W:38)	BW400 (A:44, W:49)
SATP-S8M SPAS	19	48.38	47.01	55	40	12, 14	12, 14	12, 14	12, 14	12, 14	12, 14	12, 14
	20	50.93	49.56	58	40	12, 14	12, 14	12, 14	12, 14	12, 14	12, 14	12, 14
	21	53.48	52.10	61	45	12 ~ 16	12 ~ 16	12 ~ 16	12 ~ 16	12 ~ 16	12 ~ 16	12 ~ 16
	22	56.02	54.65	61	45	12 ~ 16	12 ~ 16	12 ~ 16	12 ~ 16	12 ~ 16	12 ~ 16	12 ~ 16
	24	61.12	59.74	67	50	12 ~ 19	12 ~ 19	12 ~ 19	12 ~ 19	12 ~ 19	12 ~ 19	12 ~ 19
	25	63.66	62.29	70	56	12 ~ 20	12 ~ 20	12 ~ 20	12 ~ 20	12 ~ 20	12 ~ 20	12 ~ 20
	26	66.21	64.84	74	58	14 ~ 22	14 ~ 22	14 ~ 22	14 ~ 22	14 ~ 22	14 ~ 22	14 ~ 22
	28	71.30	69.93	80	60	14 ~ 22	14 ~ 22	14 ~ 22	14 ~ 22	14 ~ 22	14 ~ 22	14 ~ 22
	30	76.39	75.02	87	67	14 ~ 28	14 ~ 28	14 ~ 28	14 ~ 22	14 ~ 28	14 ~ 28	14 ~ 28
	32	81.49	80.12	87	67	14 ~ 28	14 ~ 28	14 ~ 28	14 ~ 22	14 ~ 28	14 ~ 28	14 ~ 28
	34	86.58	85.21	95	75	16 ~ 32	16 ~ 32	16 ~ 32	16 ~ 22	16 ~ 32	16 ~ 32	16 ~ 32
	36	91.67	90.30	99	80	16 ~ 32	16 ~ 32	16 ~ 32	16 ~ 22	16 ~ 32	16 ~ 32	16 ~ 32
	38	96.77	95.39	104	84	16 ~ 32	16 ~ 32	16 ~ 32	16 ~ 22	16 ~ 32	16 ~ 32	16 ~ 32
	40	101.86	100.49	111	90	20 ~ 32	20 ~ 35	20 ~ 35	20, 22	20 ~ 35	20 ~ 35	20 ~ 35
	44	112.05	110.67	119	100	20 ~ 32	20 ~ 35	20 ~ 35	20, 22	20 ~ 35	20 ~ 35	20 ~ 35
	48	122.23	120.86	127	105	20 ~ 32	20 ~ 45	20 ~ 45	20, 22	20 ~ 45	20 ~ 45	20 ~ 45
50	127.32	125.95	135	115	20 ~ 32	20 ~ 45	20 ~ 50	20, 22	20 ~ 50	20 ~ 50	20 ~ 50	
60	152.79	151.42	160	140	20 ~ 32	20 ~ 45	20 ~ 50	20, 22	20 ~ 50	20 ~ 50	20 ~ 50	
72	183.35	181.97	190	170	20 ~ 32	20 ~ 45	20 ~ 50	20, 22	20 ~ 50	20 ~ 50	20 ~ 50	

• Please refer to the below table for more specific available ID(d) information.

#### A.P.LOCK

(Unit:mm)

Available ID (d)		12	14	15	16	17	18	19	20	22	24	25	28	30	32	35	40	45	50
Max. Permissible Torque (N·m)	I & O type	50	65	70	75	110	115	120	220	290	320	350	380	410	440	720	810	1,200	1,500
Max. Permissible Thrust Load (kN)	I & O type	8.4	9.5	9.5	9.5	12.6	12.6	12.6	21.6	26	26	27.2	27	27	27	41.1	40.2	52.9	56.3
D	I & O type	28.5	30.5	31.5	33	33.5	34.5	35.5	42	44	46	47	50	52	54	62	67	72	77
N	I & O type	6.5	6.5	6.5	6.5	6.5	6.5	6.5	8	8	8	8	8.5	8.5	8.5	10	10	10	10.5

• Keyway is **NOT** available for SPAS series.

• Surface treatment may not be applied on inner surface of Pulley's body.

### How to Order

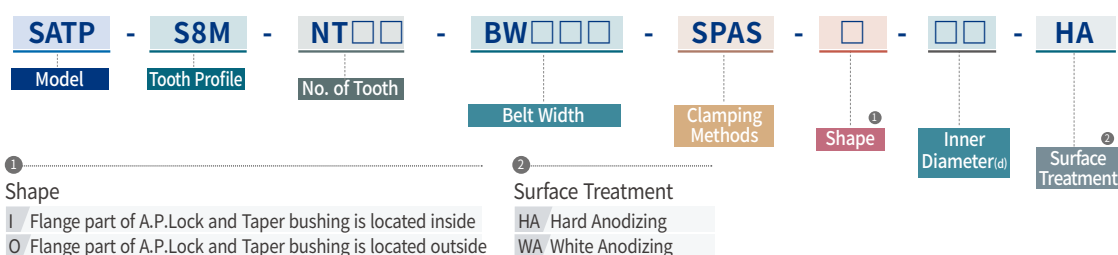

# SATP-S8M SERIES : SPB

## High Strength Aluminum Alloy Timing Pulley

+ Taper Bushing (Steel) Mounted Type

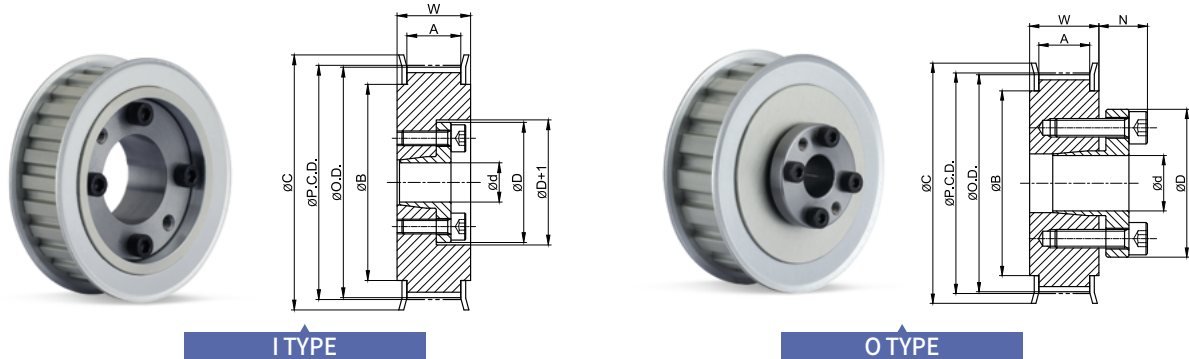

### Dimensions/Performance

**TIMING PULLEY**

(Unit:mm)

TYPE	NT	P.C.D.	O.D.	C	B	ID Range (I type)				ID Range (O type)			
						BW150 (A:17, W:22)	BW250 (A:28, W:33)	BW300 (A:33, W:38)	BW400 (A:44, W:49)	BW150 (A:17, W:22)	BW250 (A:28, W:33)	BW300 (A:33, W:38)	BW400 (A:44, W:49)
SATP-S8M SPB	18	45.84	44.46	52	36	-	12	-	-	12	12	-	-
	19	48.38	47.01	55	40	12	12 ~ 15	15	-	12 ~ 15	12 ~ 15	15	-
	20	50.93	49.56	58	40	12	12 ~ 15	15	-	12 ~ 17	12 ~ 17	15 ~ 17	-
	21	53.48	52.10	61	45	12	12 ~ 17	15 ~ 17	16, 17	12 ~ 17	12 ~ 17	15 ~ 17	16, 17
	22	56.02	54.65	61	45	12	12 ~ 17	15 ~ 17	16, 17	12 ~ 17	12 ~ 17	15 ~ 17	16, 17
	24	61.12	59.74	67	50	12	12 ~ 17	15 ~ 17	16, 17	12 ~ 17	12 ~ 17	15 ~ 17	16, 17
	25	63.66	62.29	70	56	12	12 ~ 25	15 ~ 25	16 ~ 25	12 ~ 25	12 ~ 25	15 ~ 25	16 ~ 25
	26	66.21	64.84	74	58	-	14 ~ 25	15 ~ 25	16 ~ 25	14 ~ 25	14 ~ 25	15 ~ 25	16 ~ 25
	28	71.30	69.93	80	60	-	14 ~ 25	15 ~ 25	16 ~ 25	14 ~ 25	14 ~ 25	15 ~ 25	16 ~ 25
	30	76.39	75.02	87	67	-	14 ~ 32	15 ~ 32	16 ~ 32	14 ~ 32	14 ~ 32	15 ~ 32	16 ~ 32
	32	81.49	80.12	87	67	-	14 ~ 32	15 ~ 32	16 ~ 32	14 ~ 32	14 ~ 32	15 ~ 32	16 ~ 32
	34	86.58	85.21	95	75	-	16 ~ 35	16 ~ 35	16 ~ 35	16 ~ 35	16 ~ 35	16 ~ 35	16 ~ 35
	36	91.67	90.30	99	80	-	16 ~ 35	16 ~ 35	16 ~ 35	16 ~ 35	16 ~ 35	16 ~ 35	16 ~ 35
	38	96.77	95.39	104	84	-	16 ~ 35	16 ~ 35	16 ~ 35	16 ~ 35	16 ~ 35	16 ~ 35	16 ~ 35
	40	101.86	100.49	111	90	-	20 ~ 35	20 ~ 35	20 ~ 35	20 ~ 35	20 ~ 35	20 ~ 35	20 ~ 35
	44	112.05	110.67	119	100	-	20 ~ 35	20 ~ 35	20 ~ 35	20 ~ 35	20 ~ 35	20 ~ 35	20 ~ 35
	48	122.23	120.86	127	105	-	20 ~ 35	20 ~ 35	20 ~ 35	20 ~ 35	20 ~ 35	20 ~ 35	20 ~ 35
50	127.32	125.95	135	115	-	20 ~ 35	20 ~ 35	20 ~ 35	20 ~ 35	20 ~ 35	20 ~ 35	20 ~ 35	
60	152.79	151.42	160	140	-	20 ~ 35	20 ~ 35	20 ~ 35	20 ~ 35	20 ~ 35	20 ~ 35	20 ~ 35	

- Please refer to the below table for more specific available ID(d) information.
- Due to structural reasons, the following I type ID ranges (from 12 to 30 (BW250), from 12 to 32 (BW300) & all IDs (BW400)) use O type taper bushings as an exception.

**TAPER BUSHING**

(Unit:mm)

Available ID (d)		12	14	15	16	17	18	19	20	22	24	25	28	30	32	35
Max. Permissible Torque (N·m)	I type	23	37	39	42	45	48	49	97	110	121	124	141	149	163	173
	O type	48	73	78	83	88	154	163	171	186	206	216	353	382	412	451
Max. Permissible Thrust Load (kN)	I type	3.76	5.21	5.1	5.17	5.23	5.28	5.12	9.68	9.98	10	9.9	10	9.89	10.12	9.88
	O type	5.34	5.34	5.34	5.34	5.34	8.74	8.74	8.74	8.74	8.74	8.74	8.74	8.74	8.74	8.74
D	I type	31	36	37	38	39	40	42	46	47	49	51	53	56	58	61
	O type	32	35	36	37	38	43	45	46	48	50	52	54	57	59	63
N	O type	10.5	12	12	13	13	14	14	14	14	14	14	15.5	15.5	16.5	16.5

- Keyway is **NOT** available for SPB series.
- Surface treatment may not be applied on inner surface of Pulley's body.

### How to Order



# SATP-S8M SERIES : SC

## High Strength Aluminum Alloy Timing Pulley

+ Side-clamp (High Strength Aluminum Alloy) Type

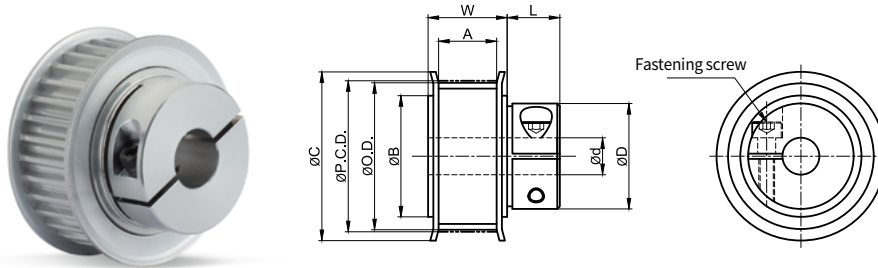

### Dimensions / Performance

#### TIMING PULLEY

(Unit:mm)

TYPE	NT	P.C.D.	O.D.	C	B	D	L	Fastening Screw		ID Range	
								Size	Fastening Torque(N·m)	BW150 (A:17, W:22)	BW250 (A:28, W:33)
SATP-S8M SC	20	50.93	49.56	58	40	36	14	M4X14	3.5	12 ~ 14	12 ~ 14
	22	56.02	54.65	61	45	41	16	M5X16	6	12 ~ 16	12 ~ 16
	24	61.12	59.74	67	50	46	16	M5X16	6	12 ~ 19	12 ~ 19
	25	63.66	62.29	70	56	46	16	M5X16	6	12 ~ 19	12 ~ 19
							46	16	M5X16	6	15 ~ 19
	28	71.30	69.93	80	60	46	16	M5X16	6	15 ~ 19	15 ~ 19
							55	17	M6X20	12	20 ~ 25
	30	76.39	75.02	87	67	46	16	M5X16	6	15 ~ 19	15 ~ 19
							55	17	M6X20	12	20 ~ 25
	32	81.49	80.12	87	67	46	16	M5X16	6	18, 19	18, 19
							55	17	M6X20	12	20 ~ 25
	34	86.58	85.21	95	75	46	16	M5X16	6	18, 19	18, 19
							55	17	M6X20	12	20 ~ 25
	36	91.67	90.30	99	80	46	16	M5X16	6	18, 19	18, 19
55							17	M6X20	12	20 ~ 25	20 ~ 25

- Keyway is available for SC series.
- Surface treatment may not be applied on inner surface of Pulley's body.

### Slip Torque (N · m) by Inner diameters

ID Range (d)	12	13	14	15	16	17	18	19	20	21	22	23	24	25
Slip Torque (N·m)	2.6	2.6	7.6	7.6	7.6	7.6	7.6	7.6	48	48	66	66	95	95

### How to Order

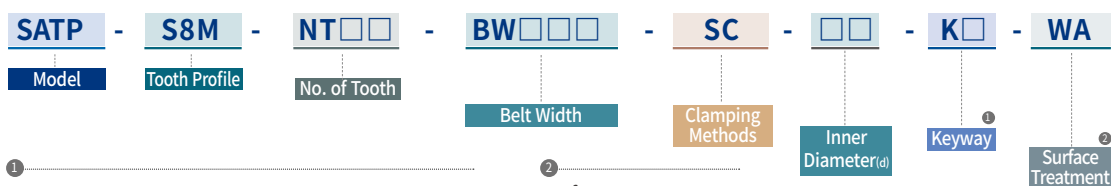

- ① Keyway  
 No mark No Keyway  
 K(b size) Keyway processed according to the indicated b size.

- ② Surface Treatment  
 WA White Anodizing

# SATP-S8M SERIES : IDOC, IDTC

High Strength Aluminum Alloy Timing Pulley

+ Bearing Mounted Type (Center bearing)

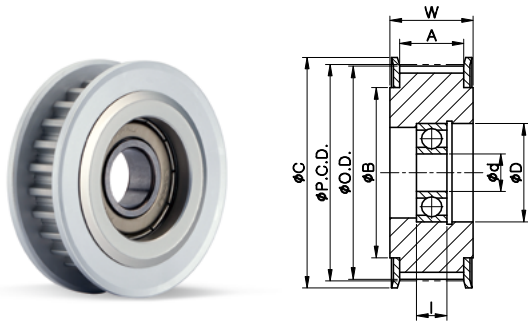

IDOC TYPE (Bearing 1 pc.)

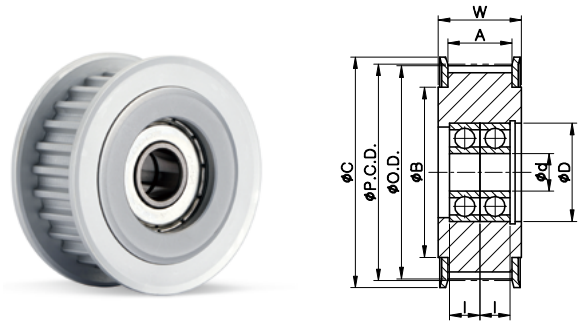

IDTC TYPE (Bearing 2 pcs.)

## Dimensions/Performance

TIMING PULLEY

(Unit: mm)

TYPE	NT	P.C.D.	O.D.	C	B	Bearing	D	I	ID (d)		ID (d)	
									IDOC(1 pc)	IDTC(2 pcs)	BW150 (A:17, W:22)	BW250 (A:28, W:33)
SATP-S8M IDOC IDTC	20	50.93	49.56	58	40	6201ZZ	32	10	12	12	-	-
						6202ZZ	35	11	15	15	-	-
	22	56.02	54.65	61	45	6201ZZ	32	10	12	12	-	-
						6202ZZ	35	11	15	15	15	-
	24	61.12	59.74	67	50	6201ZZ	32	10	12	12	-	-
						6202ZZ	35	11	15	15	15	15
						6004ZZ	42	12	20	-	-	-
	25	63.66	62.29	70	56	6904ZZ	37	9	-	20	20	-
						6202ZZ	35	11	15	15	15	-
						6004ZZ	42	12	-	20	20	20
	26	66.21	64.84	74	58	6204ZZ	47	14	20	-	-	-
						6202ZZ	35	11	15	15	15	-
						6202ZZ	35	11	15	15	15	-
	28	71.30	69.93	80	60	6004ZZ	42	12	-	20	-	-
						6202ZZ	35	11	15	15	15	-
						6202ZZ	35	11	15	15	15	-
	30	76.39	75.02	87	67	6004ZZ	42	12	-	20	-	-
						6204ZZ	47	14	20	-	20	20
						6005ZZ	47	12	25	25	25	-
						6205ZZ	52	15	-	-	-	25
32	81.49	80.12	87	67	6204ZZ	47	14	20	-	-	-	
					6005ZZ	47	12	25	-	-	-	
34	86.58	85.21	95	75	6204ZZ	47	14	20	-	-	-	
36	91.67	90.30	99	80	6005ZZ	47	12	25	-	-	-	
40	101.86	100.49	111	90	6205ZZ	52	15	25	-	-	-	

## How to Order

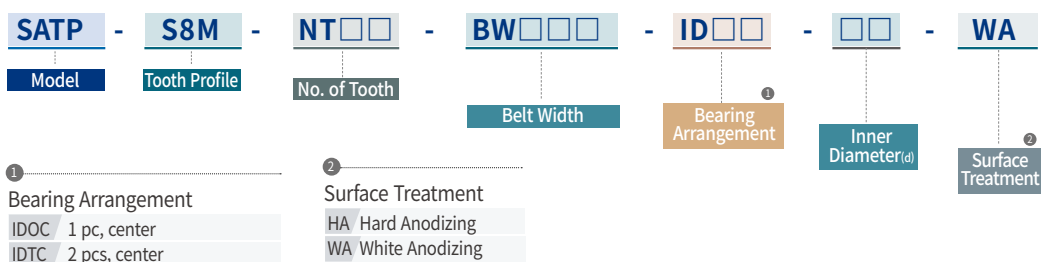

# SATP-S8M SERIES : IDTS

## High Strength Aluminum Alloy Timing Pulley

+ Bearing Mounted Type (Both sides bearing)

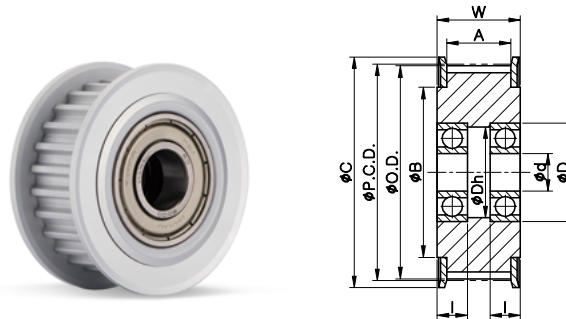

IDTS TYPE (Bearing 2 pcs.)

### Dimensions / Performance

#### TIMING PULLEY

(Unit:mm)

TYPE	NT	P.C.D.	O.D.	C	B	Bearing	D	Dh	I	ID (d) IDTS(2 pcs)			
										BW150 (A:17, W:22)	BW250 (A:28, W:33)	BW300 (A:33, W:38)	BW400 (A:44, W:49)
SATP-S8M IDTS	22	56.02	54.65	61	45	6201ZZ	32	27	10	-	12	12	12
						6002ZZ	32	29	9	15	-	-	-
						6202ZZ	35	30	11	-	15	15	-
	24	61.12	59.74	67	50	6201ZZ	32	27	10	-	12	12	12
						6904ZZ	37	32	9	20	20	20	-
	25	63.66	62.29	70	56	6201ZZ	32	27	10	-	12	12	12
						6204ZZ	47	41	14	-	20	20	20
						6904ZZ	37	32	9	20	-	-	-
	26	66.21	64.84	74	58	6001ZZ	28	25	8	12	12	-	-
						6201ZZ	32	27	10	-	-	12	12
	28	71.30	69.93	80	60	6202ZZ	35	30	11	-	15	15	15
	30	76.39	75.02	87	67	6002ZZ	32	29	9	15	15	-	-
						6202ZZ	35	30	11	-	-	15	15
						6004ZZ	42	37	12	-	20	-	-
						6204ZZ	47	41	14	-	-	20	20
						6205ZZ	52	47	15	-	25	25	25
	32	81.49	80.12	87	67	6204ZZ	47	41	14	-	20	20	20
						6205ZZ	52	47	15	-	25	25	25
	34	86.58	85.21	95	75	6204ZZ	47	41	14	-	20	20	20
	36	91.67	90.30	99	80	6205ZZ	52	47	15	-	25	25	25
40	101.86	100.49	111	90	6005ZZ	47	43	12	-	25	-	-	
					6205ZZ	52	47	15	-	-	25	25	
					6206ZZ	62	57	16	-	-	30	30	
					6208ZZ	80	73.5	18	-	-	-	40	

### How to Order

**SATP** - **S8M** - **NT□□** - **BW□□□** - **IDTS** - **□□** - **WA**

Model      Tooth Profile      No. of Tooth      Belt Width      Bearing Arrangement      Inner Diameter (d)      Surface Treatment

① Surface Treatment  
 HA Hard Anodizing  
 WA White Anodizing

# SATP-1.5GT SERIES

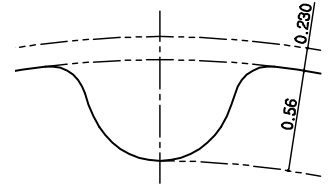

Tooth Profile: 1.5GT / Pitch: 1.5mm

High Strength Aluminum Alloy Timing Pulley  
+ Side-clamp (High Strength Aluminum Alloy) Type

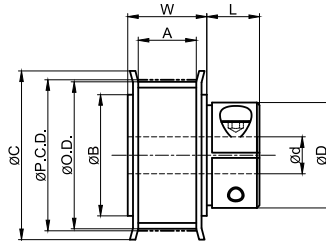
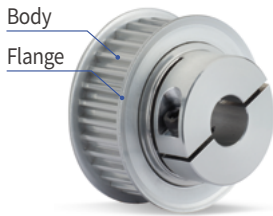

**SIDE-CLAMP Type (SC)**

## Structure and Material

Structure	Material	Surface Treatment
Pulley	High Strength Aluminum Alloy	Anodizing (White)
Fastening Screw	SCM435	Black Oxide

## Standard Dimensions Range

Clamping Methods	OD (mm)	No. of Tooth (ea)	Belt Width (mm)
SC	17.2 ~ 22.9	36 ~ 48	3

## Dimensions / Performance

**TIMING PULLEY**

(Unit: mm)

TYPE	NT	P.C.D.	O.D.	C	B	D	L	Fastening Screw		ID Range
								Size	Fastening Torque(N·m)	BW030 (A:4, W:7.3)
SATP-1.5GT SC	36	17.2	16.7	22	13	10	6	M1.6	0.25	3
	38	18.1	17.7	22	13	10	6	M1.6	0.25	3
	40	19.1	18.6	23	14	10	6	M1.6	0.25	3
	42	20.1	19.6	24	15	12	7	M2	0.5	3 ~ 5
	44	21	20.6	25	17	14	7	M2	0.5	3 ~ 6
	46	22	21.5	25	17	14	7	M2	0.5	3 ~ 6
	48	22.9	22.5	26	18	14	7	M2	0.5	3 ~ 6

- Keyway is available for SC series.
- Surface treatment may not be applied on inner surface of Pulley's body.

## How to Order

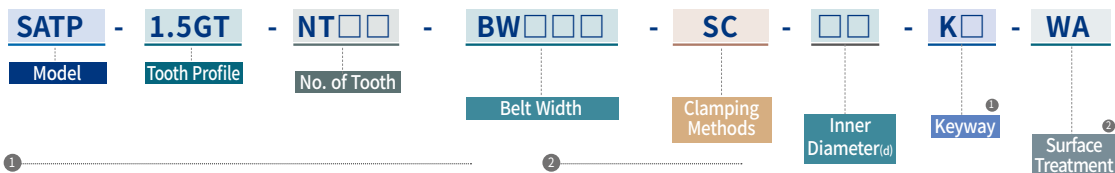

- ① Keyway  
 No mark No Keyway  
 K(b size) Keyway processed according to the indicated b size.
- ② Surface Treatment  
 WA White Anodizing

## SATP-2GT SERIES



## High Strength Aluminum Alloy Timing Pulley

### + Side-clamp (High Strength Aluminum Alloy) Type

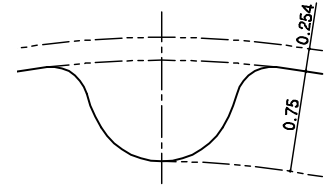

Tooth Profile: 2GT / Pitch: 2mm

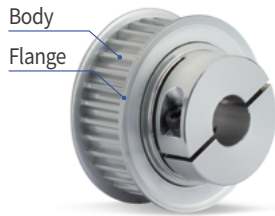

SIDE-CLAMP Type (SC)

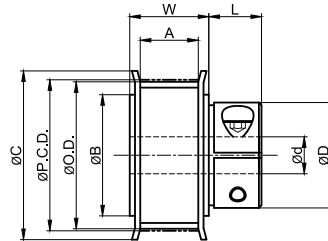

## Structure and Material

Structure	Material	Surface Treatment
Pulley	High Strength Aluminum Alloy	Anodizing (White)
Fastening Screw	SCM435	Black Oxide

## Standard Dimensions Range

Clamping Methods	OD (mm)	No. of Tooth (ea)	Belt Width (mm)
SC	17.2 ~ 45.8	27 ~ 72	4, 6

## Dimensions / Performance

## TIMING PULLEY

(Unit:mm)

TYPE	NT	P.C.D.	O.D.	C	B	D	L	Fastening Screw		ID Range	
								Size	Fastening Torque(N·m)	BW040 (A:5,W:8.3)	BW060 (A:7,W:10.3)
SATP-2GT SC	27	17.2	16.7	22	13	10	6	M1.6	0.25	3	3
	28	17.8	17.3	23	14	10	6	M1.6	0.25	3	3
	29	18.5	18	23	14	10	6	M1.6	0.25	3	3
	30	19.1	18.6	24	15	12	7	M2	0.5	3~5	3~5
	32	20.4	19.9	25	17	12	7	M2	0.5	3~5	3~5
	34	21.7	21.1	27	18	14	7	M2	0.5	3~6	3~6
	36	22.9	22.4	27	18	14	7	M2	0.5	3~6	3~6
	38	24.2	23.7	29	20	18	7.5	M2	0.5	3~8	3~8
	40	25.5	25	30	21	18	7.5	M2	0.5	3~8	3~8
	44	28	27.5	32	23	20	7.5	M2	0.5	5~10	5~10
	48	30.6	30.1	35	26	20	7.5	M2	0.5	5~10	5~10
	50	31.8	31.3	36	27	20	7.5	M2	0.5	5~10	5~10
	60	38.2	37.7	42	33	30	11	M3	1.5	8~14	8~14
	72	45.8	45.3	51	42	38	14.3	M4	2.5	8~20	8~20

- Keyway is available for SC series.
- Surface treatment may not be applied on inner surface of Pulley's body.

## How to Order

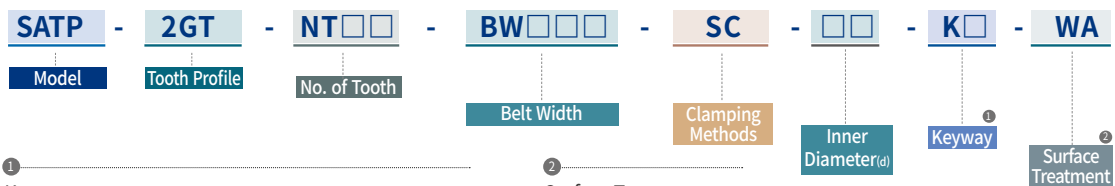

- ① Keyway  
No mark No Keyway  
K(b size) Keyway processed according to the indicated b size.

- ② Surface Treatment  
WA White Anodizing

# SATP-3GT SERIES



## High Strength Aluminum Alloy Timing Pulley

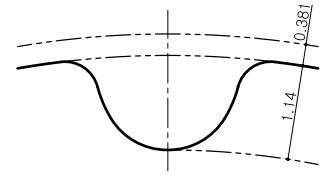

Tooth Profile: 3GT / Pitch: 3mm

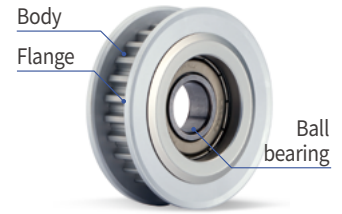
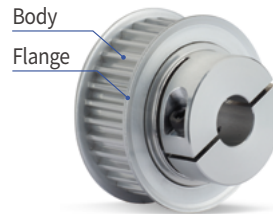
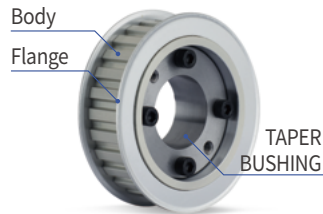
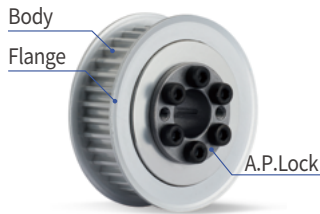

A.P.LOCK Type (SPA□)

TAPER BUSHING Type (SPB)

SIDE-CLAMP Type (SC)

IDLER Type (ID□□)

### Structure and Material

Clamping methods		Category	Pulley (Body/Flange)	A.P.LOCK	TAPER BUSHING	Fastening Screw
SPA□	SPAA	Material	High Strength Aluminum Alloy	High Strength Aluminum Alloy	-	SCM435
		Surface Treatment	Anodizing (White/Hard)	Anodizing (Hard)	-	Electroless Nickel Plating
	SPAS	Material	High Strength Aluminum Alloy	Steel	-	SCM435
		Surface Treatment	Anodizing (White/Hard)	-	-	Black Oxide
SPB	Material	High Strength Aluminum Alloy	-	Steel	SCM435	
	Surface Treatment	Anodizing (White/Hard)	-	-	Black Oxide	
SC	Material	High Strength Aluminum Alloy	-	-	SCM435	
	Surface Treatment	Anodizing (White)	-	-	Black Oxide	
ID□□	IDOC	Material	High Strength Aluminum Alloy	-	-	-
		Surface Treatment	Anodizing (White/Hard)	-	-	-
	IDTC IDTS					

### Standard Dimensions Range

Clamping Methods		OD (mm)	No. of Tooth (ea)	Belt Width (mm)
SPA□	SPAA	28.65 ~ 57.30	30 ~ 60	9, 15
	SPAS	32.47 ~ 57.30	34 ~ 60	9, 15
SPB		32.47 ~ 57.30	34 ~ 60	9, 15
SC		22.92 ~ 57.30	24 ~ 60	6, 9
ID□□	IDOC	28.65 ~ 57.30	30 ~ 60	9
	IDTC	38.20 ~ 47.75	40 ~ 50	15
	IDTS	28.65 ~ 57.30	30 ~ 60	9, 15

### Clamping Methods

SPAA	A.P.Lock (High Strength Aluminum Alloy)	○	
SPAS	A.P.Lock (Steel)	○	
SPB	Taper Bushing	○	
SC	Side-clamp (High Strength Aluminum Alloy)	General	○
		With Keyway	○
IDOC	IDLER	Center bearing (1pc)	○
IDTC		Center bearing (2pcs)	○
IDTS		Both sides bearing (2pcs)	○

### How to Order

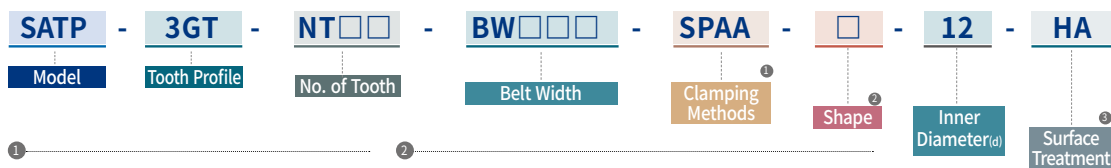

- ① Clamping Methods
- SPAA A.P.Lock (High Strength Aluminum Alloy)
  - SPAS A.P.Lock (Steel)
  - SPB Taper Bushing
  - SC Side-clamp
  - ID□□ IDLER Type

- ② Shape
- I Flange part of A.P.Lock and Taper bushing is located inside
  - O Flange part of A.P.Lock and Taper bushing is located outside

- ③ Surface Treatment
- HA Hard Anodizing
  - WA White Anodizing

※ For SC clamping type, only white anodizing (WA) surface treatment is available.

# SATP-3GT SERIES : SPAA

## High Strength Aluminum Alloy Timing Pulley

+ A.P.LOCK (High Strength Aluminum Alloy) Mounted Type

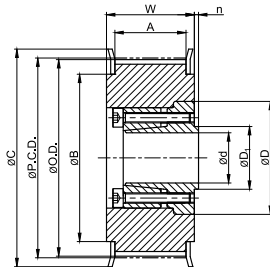

I TYPE

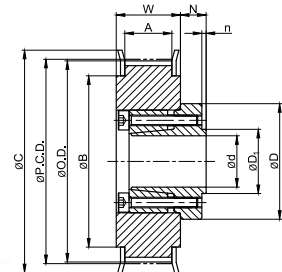

O TYPE

### Dimensions / Performance

#### TIMING PULLEY

(Unit:mm)

TYPE	NT	P.C.D.	O.D.	C	B	ID Range (I type)	ID Range (O type)
						BW150 (A:16.3, W:20)	BW090 (A:10.3, W:14)
SATP-3GT SPAA	30	28.65	27.89	32	23	-	6
	34	32.47	31.71	36	27	-	6, 8
	36	34.38	33.62	38	29	-	6, 8
	40	38.20	37.44	42	33	8	8, 10
	44	42.02	41.26	46	36	8 ~ 12	8 ~ 12
	48	45.84	45.08	49	40	8 ~ 14	8 ~ 12
	50	47.75	46.99	51	42	8 ~ 14	8 ~ 14
	60	57.30	56.54	61	52	8 ~ 14	8 ~ 14

- Please refer to the below table for more specific available ID(d) information.

#### A.P.LOCK

(Unit:mm)

Available ID (d)		6	8	10	12	14
Max. Permissible Torque (N·m)	I & O type	4	6	8	12	18
Max. Permissible Thrust Load (kN)	I & O type	1.33	1.51	1.63	1.99	2.56
D	I & O type	20	22	24	27	29
D <sub>1</sub>	I & O type	8.5	11	13	15	17
N / n	I & O type	4 / 0.5	5 / 0.5	5 / 0.5	6 / 1	6 / 1

- Keyway is **NOT** available for SPAA series.
- Surface treatment may not be applied on inner surface of Pulley's body.

### How to Order

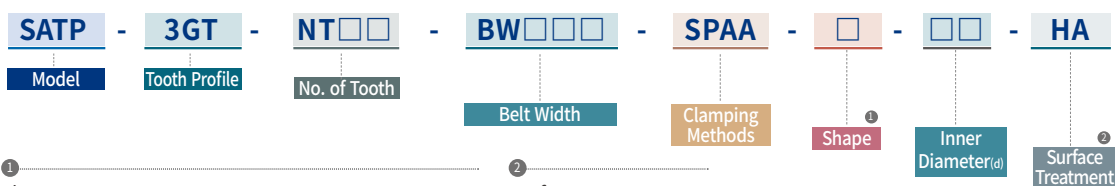

① Shape

- I Flange part of A.P.Lock and Taper bushing is located inside
- O Flange part of A.P.Lock and Taper bushing is located outside

② Surface Treatment

- HA Hard Anodizing
- WA White Anodizing

# SATP-3GT SERIES : SPAS

## High Strength Aluminum Alloy Timing Pulley

+ A.P.LOCK (Steel) Mounted Type

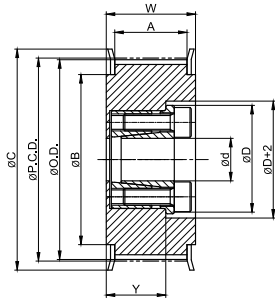

I TYPE

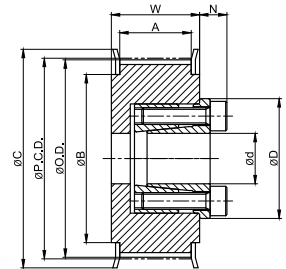

O TYPE

### Dimensions / Performance

**TIMING PULLEY**

(Unit:mm)

TYPE	NT	P.C.D.	O.D.	C	B	ID Range (I type)		ID Range (O type)	
						BW150 (A:16.3, W:20)	BW090 (A:10.3, W:14)	BW150 (A:16.3, W:20)	
SATP-3GT SPAS	34	32.47	31.71	36	27	6	6	6	
	36	34.38	33.62	38	29	6	6	6	
	40	38.20	37.44	42	33	8	8	8	
	44	42.02	41.26	46	36	8, 10	8, 10	8, 10	
	48	45.84	45.08	49	40	8, 10	8, 10	8 ~ 12	
	50	47.75	46.99	51	42	8, 10	8, 10	8 ~ 14	
60	57.30	56.54	61	61	52	8, 10	8, 10	8 ~ 17	

• Please refer to the below table for more specific available ID(d) information.

**A.P.LOCK**

(Unit:mm)

Available ID (d)		6	8	10	12	14	15	16	17
Max. Permissible Torque (N·m)	I & O type	14	22	25	50	65	70	75	110
Max. Permissible Thrust Load (kN)	I & O type	4.7	5.6	5.6	5.6	9.5	9.5	9.5	12.6
D	I & O type	21.5	23.5	25.5	28.5	30.5	31.5	33	33.5
N	I & O type	6	6	6	6.5	6.5	6.5	6.5	6.5

- Keyway is **NOT** available for SPAS series.
- Surface treatment may not be applied on inner surface of Pulley's body.

### How to Order

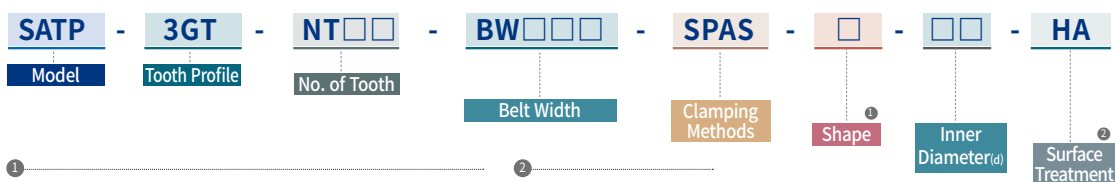

- ① Shape
- I Flange part of A.P.Lock and Taper bushing is located inside
  - O Flange part of A.P.Lock and Taper bushing is located outside

- ② Surface Treatment
- HA Hard Anodizing
  - WA White Anodizing

# SATP-3GT SERIES : SPB

## High Strength Aluminum Alloy Timing Pulley

+ Taper Bushing (Steel) Mounted Type

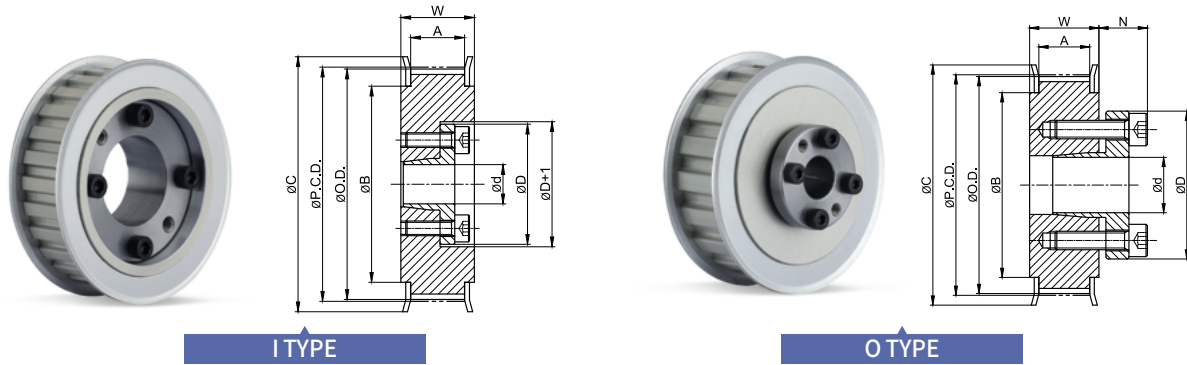

### Dimensions / Performance

#### TIMING PULLEY

(Unit:mm)

TYPE	NT	P.C.D.	O.D.	C	B	ID Range (I type)		ID Range (O type)	
						BW090 (A:10.3, W:14)	BW150 (A:16.3, W:20)	BW090 (A:10.3, W:14)	BW150 (A:16.3, W:20)
SATP-3GT SPB	34	32.47	31.71	36	27	6	6	8	8
	36	34.38	33.62	38	29	6	6	8	8
	40	38.20	37.44	42	33	8	8	8 ~ 11	8 ~ 11
	44	42.02	41.26	46	36	8	10 ~ 12	8 ~ 14	8 ~ 14
	48	45.84	45.08	49	40	8	10 ~ 12	8 ~ 16	8 ~ 16
	50	47.75	46.99	51	42	8	10 ~ 12	8 ~ 17	8 ~ 17
60	57.30	56.54	61	52	8	10 ~ 12	8 ~ 19	8 ~ 19	

- Please refer to the below table for more specific available ID(d) information.

#### TAPER BUSHING

(Unit:mm)

Available ID (d)		6	8	10	11	12	14	15	16	17	18	19
Max. Permissible Torque (N·m)	I type	5.6	8.5	18	20	23						
	O type		16	39	43	48	73	78	83	88	154	163
Max. Permissible Thrust Load (kN)	I type	1.87	2.12	3.59	3.63	3.76						
	O type		4	5.34	5.34	5.34	5.34	5.34	5.34	5.34	8.74	8.74
D	I type	22.5	24.5	29	30	31						
	O type		25.5	30	31	32	35	36	37	38	43	45
N	O type		8.5	10.5	10.5	11.5	13	13	14	14	15	15

- Keyway is **NOT** available for SPB series.
- Surface treatment may not be applied on inner surface of Pulley's body.

### How to Order

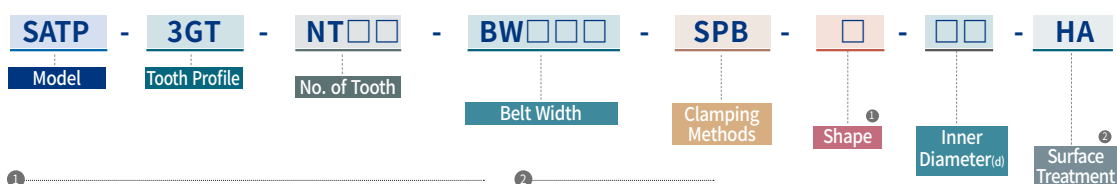

① Shape

- I Flange part of A.P.Lock and Taper bushing is located inside
- O Flange part of A.P.Lock and Taper bushing is located outside

② Surface Treatment

- HA Hard Anodizing
- WA White Anodizing

# SATP-3GT SERIES : SC

## High Strength Aluminum Alloy Timing Pulley

+ Side-clamp (High Strength Aluminum Alloy) Type

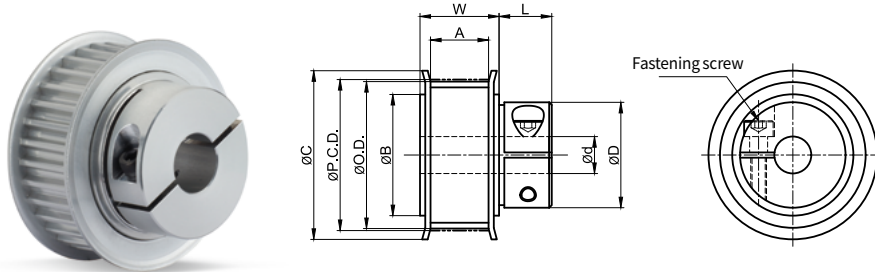

### Dimensions / Performance

#### TIMING PULLEY

(Unit:mm)

TYPE	NT	P.C.D.	O.D.	C	B	D	L	Fastening Screw		ID Range	
								Size	Fastening Torque(N·m)	BW060 (A:7.3, W:11)	BW090 (A:10.3, W:14)
SATP-3GT SC	24	22.92	22.16	26	18	13	9	M2X8	0.4	4	4
	26	24.83	24.07	28	19	13	9	M2X8	0.4	4	4
	28	26.74	25.98	30	21	13	9	M2X8	0.4	4	4
	30	28.65	27.89	32	23	20	9	M2X8	0.4	6, 8	6, 8
	32	30.56	29.80	34	25	20	9	M2X8	0.4	6, 8	6, 8
	36	34.38	33.62	38	29	26	12.5	M3X10	1.5	6, 8	6, 8
	40	38.20	37.44	42	33	26	12.5	M3X10	1.5	8, 10	8, 10
	44	42.02	41.26	46	36	31	14	M4X14	3.5	8, 10	8, 10
	48	45.84	45.08	49	40	33	14	M4X14	3.5	8 ~ 12	8 ~ 12
	50	47.75	46.99	51	42	36	14	M4X14	3.5	8 ~ 14	8 ~ 14
60	57.30	56.54	61	52	41	15.5	M5X16	6	8 ~ 16	8 ~ 16	

- Keyway is available for SC series.
- Surface treatment may not be applied on inner surface of Pulley's body.

### Slip Torque (N·m) by Inner diameters

ID Range (d)	4	6	8	10	11	12	13	14	15	16
Slip Torque N·m	0.16	0.95	2.6	2.6	2.6	2.6	2.6	7.6	7.6	7.6

### How to Order

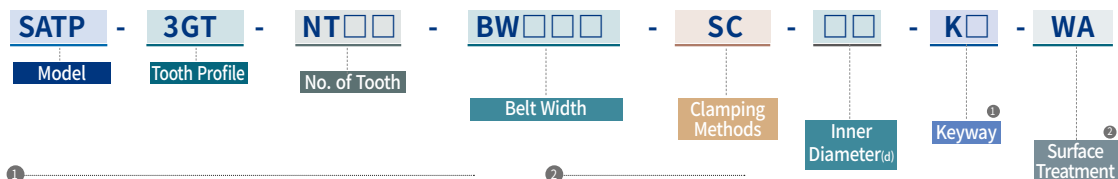

- ① Keyway  
 No mark No Keyway  
 K(b size) Keyway processed according to the indicated b size.

- ② Surface Treatment  
 WA White Anodizing

# SATP-3GT SERIES : IDOC, IDTC

## High Strength Aluminum Alloy Timing Pulley

+ Bearing Mounted Type (Center bearing)

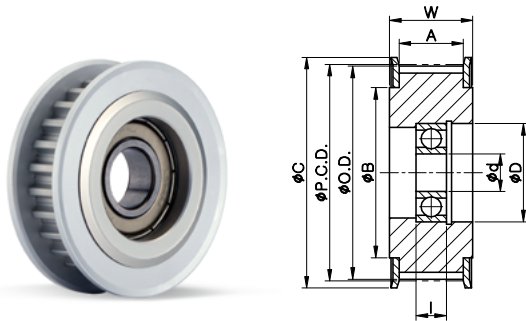

IDOC TYPE (Bearing 1 pc.)

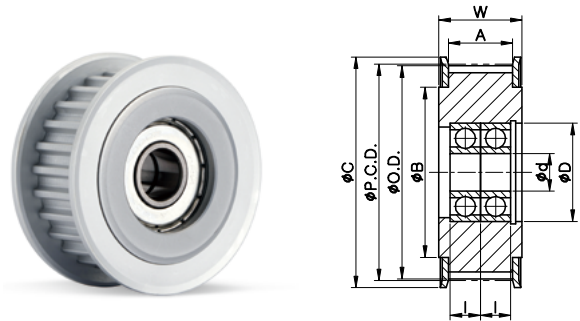

IDTC TYPE (Bearing 2 pcs.)

### Dimensions/Performance

#### TIMING PULLEY

(Unit:mm)

TYPE	NT	P.C.D.	O.D.	C	B	Bearing	D	I	ID (d)	ID (d)
									IDOC(1 pc) BW090 (A:10.3, W:14)	IDTC(2 pcs) BW150 (A:16.3, W:20)
SATP-3GT IDOC IDTC	30	28.65	27.89	32	23	626ZZ	19	6	6	-
	34	32.47	31.71	40	28	608ZZ	22	7	8	-
	36	34.38	33.62	40	28	608ZZ	22	7	8	-
	40	38.20	37.44	44	32	628ZZ	24	8	8	-
						6000ZZ	26	8	10	-
						6900ZZ	22	6	-	10
						6901ZZ	24	6	-	12
	44	42.02	41.25	48	36	628ZZ	24	8	8	-
						6000ZZ	26	8	10	-
						6900ZZ	22	6	-	10
						6001ZZ	28	8	12	-
	48	45.84	45.07	50	38	6901ZZ	24	6	-	12
						6000ZZ	26	8	10	-
						6900ZZ	22	6	-	10
	50	47.75	46.98	52	40	6000ZZ	26	8	10	-
						6900ZZ	22	6	-	10
						6001ZZ	28	8	12	-
						6901ZZ	24	6	-	12
60	57.30	56.53	61	46	6000ZZ	26	8	10	-	

### How to Order

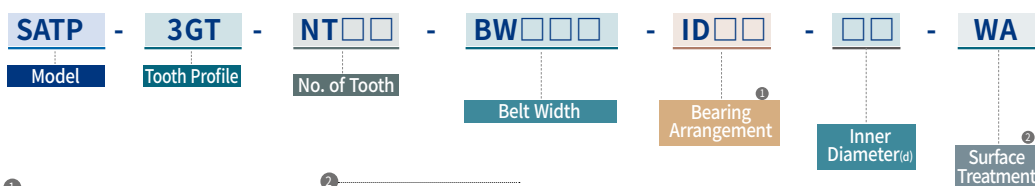

① Bearing Arrangement

IDOC 1 pc, center  
IDTC 2 pcs, center

② Surface Treatment

HA Hard Anodizing  
WA White Anodizing

# SATP-3GT SERIES : IDTS

High Strength Aluminum Alloy Timing Pulley

+ Bearing Mounted Type (Both sides bearing)

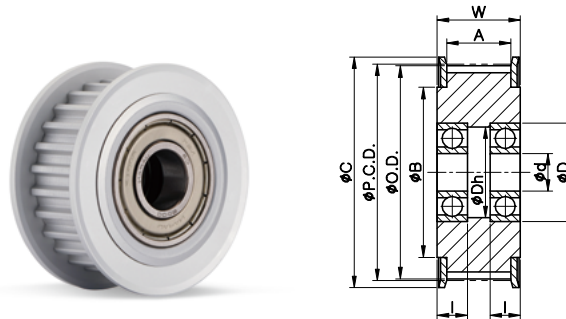

IDTS TYPE (Bearing 2 pcs.)

## Dimensions / Performance

TIMING PULLEY

(Unit:mm)

TYPE	NT	P.C.D.	O.D.	C	B	Bearing	D	Dh	I	ID (d) IDTS (2 pcs)	
										BW090 (A:10.3, W:14)	BW150 (A:16.3, W:20)
SATP-3GT IDTS	30	28.65	27.89	32	23	696ZZ	15	13	5	6	6
						688ZZ	16	14	5	8	-
	34	32.47	31.71	40	28	606ZZ	17	14.5	6	6	-
						608ZZ	22	19.5	7	-	8
						698ZZ	19	16.5	6	8	-
	36	34.38	33.62	40	28	606ZZ	17	14.5	6	6	-
						6900ZZ	22	19.5	6	10	10
	40	38.20	37.44	44	32	608ZZ	22	19.5	7	-	8
						698ZZ	19	16.5	6	8	-
						6900ZZ	22	19.5	6	10	10
						6001ZZ	28	25	8	-	12
						6901ZZ	24	22	6	12	-
	44	42.02	41.25	48	36	608ZZ	22	19.5	7	-	8
						6900ZZ	22	19.5	6	10	10
						6001ZZ	28	25	8	-	12
						6901ZZ	24	22	6	12	-
	48	45.84	45.07	50	38	6900ZZ	22	19.5	6	10	10
						6900ZZ	22	19.5	6	10	10
	50	47.75	46.98	52	40	6001ZZ	28	25	8	-	12
						6901ZZ	24	22	6	12	-
6900ZZ						22	19.5	6	10	-	
60	57.30	56.53	61	46	6900ZZ	22	19.5	6	10	-	
					6001ZZ	28	25	8	-	12	

## How to Order

**SATP** - **3GT** - **NT**□□ - **BW**□□□ - **IDTS** - □□ - **WA**

Model      Tooth Profile      No. of Tooth      Belt Width      Bearing Arrangement      Inner Diameter (d)      Surface Treatment

① Surface Treatment  
 HA Hard Anodizing  
 WA White Anodizing

## SATP-5GT SERIES



## High Strength Aluminum Alloy Timing Pulley

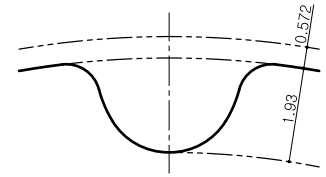

Tooth Profile: 5GT / Pitch: 5mm

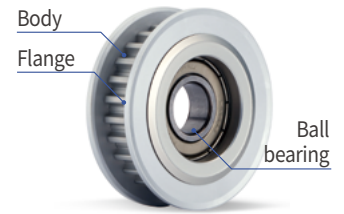
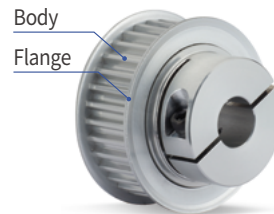
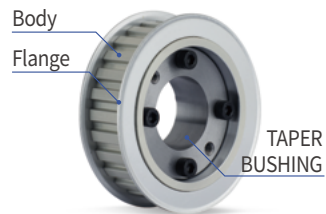
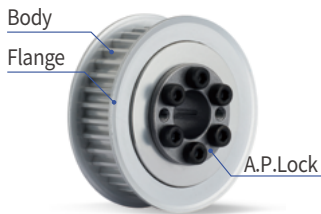

A.P.LOCK Type (SPA□)

TAPER BUSHING Type (SPB)

SIDE-CLAMP Type (SC)

IDLER Type (ID□□)

## Structure and Material

Clamping methods		Category	Pulley (Body/Flange)	A.P.LOCK	TAPER BUSHING	Fastening Screw
SPA□	SPAA	Material	High Strength Aluminum Alloy	High Strength Aluminum Alloy	-	SCM435
		Surface Treatment	Anodizing (White/Hard)	Anodizing (Hard)	-	Electroless Nickel Plating
	SPAS	Material	High Strength Aluminum Alloy	Steel	-	SCM435
		Surface Treatment	Anodizing (White/Hard)	-	-	Black Oxide
SPB	Material	High Strength Aluminum Alloy	-	Steel	SCM435	
	Surface Treatment	Anodizing (White/Hard)	-	-	Black Oxide	
SC	Material	High Strength Aluminum Alloy	-	-	SCM435	
	Surface Treatment	Anodizing (White)	-	-	Black Oxide	
ID□□	IDOC	Material	High Strength Aluminum Alloy	-	-	-
		Surface Treatment	Anodizing (White/Hard)	-	-	-
	IDTS	Material	High Strength Aluminum Alloy	-	-	-

## Standard Dimensions Range

Clamping Methods	OD (mm)	No. of Tooth (ea)	Belt Width (mm)
SPA□	SPAA	31.83 ~ 63.66	20 ~ 40
	SPAS	38.20 ~ 95.49	24 ~ 60
SPB	35.01 ~ 95.49	22 ~ 60	12, 15
SC	38.20 ~ 95.49	24 ~ 60	12, 15
ID□□	IDOC	31.83 ~ 63.66	20 ~ 40
	IDTC	31.83 ~ 63.66	15
	IDTS	31.83 ~ 63.66	20 ~ 40

## Clamping Methods

SPAA	A.P.Lock (High Strength Aluminum Alloy)	○	
SPAS	A.P.Lock (Steel)	○	
SPB	Taper Bushing	○	
SC	Side-clamp (High Strength Aluminum Alloy)	General	○
		With Keyway	○
IDOC	IDLER	Center bearing (1pc)	○
IDTC		Center bearing (2pcs)	○
IDTS		Both sides bearing (2pcs)	○

## How to Order

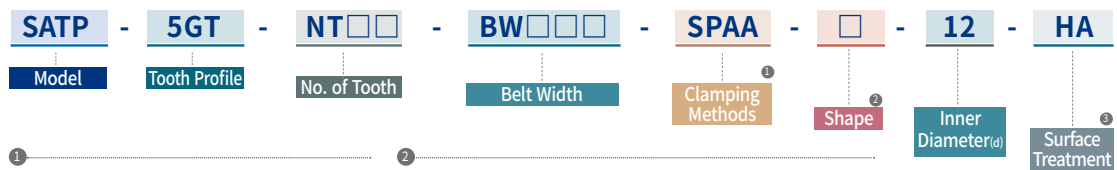

## 1 Clamping Methods

SPAA	A.P.Lock (High Strength Aluminum Alloy)
SPAS	A.P.Lock (Steel)
SPB	Taper Bushing
SC	Side-clamp
ID□□	IDLER Type

## 2 Shape

- I Flange part of A.P.Lock and Taper bushing is located inside
- O Flange part of A.P.Lock and Taper bushing is located outside

## 3 Surface Treatment

HA	Hard Anodizing
WA	White Anodizing

※ For SC clamping type, only white anodizing (WA) surface treatment is available.

# SATP-5GT SERIES : SPAA

## High Strength Aluminum Alloy Timing Pulley

+ A.P.LOCK (High Strength Aluminum Alloy) Mounted Type

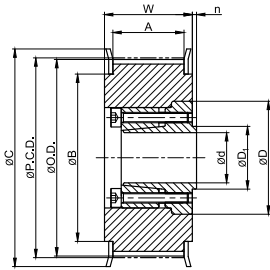

I TYPE

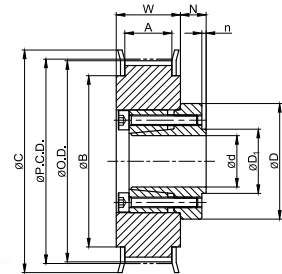

O TYPE

### Dimensions / Performance

TIMING PULLEY

(Unit:mm)

TYPE	NT	P.C.D.	O.D.	C	B	ID Range (I type)	ID Range (O type)
						BW150 (A:16.3, W:20)	BW120 (A:13.3, W:17)
SATP-5GT SPAA	20	31.83	30.69	35	24	-	6
	22	35.01	33.87	39	27	-	8
	24	38.20	37.06	42	30	-	8, 10
	25	39.79	38.65	43	32	-	8, 10
	26	41.38	40.24	45	33	8, 10	8, 10
	28	44.56	43.42	48	36	8, 10	8, 10
	30	47.75	46.61	51	39	10, 12	10, 12
	32	50.93	49.79	55	42	10 ~ 14	10 ~ 15
	34	54.11	52.97	58	46	10 ~ 14	10 ~ 16
	36	57.30	56.16	61	49	10 ~ 14	10 ~ 16
40	63.66	62.52	67	55	10 ~ 14	10 ~ 16	

• Please refer to the below table for more specific available ID(d) information.

A.P.LOCK

(Unit:mm)

Available ID (d)		6	8	10	12	14	15	16
Max. Permissible Torque (N·m)	I & O type	4	6	8	12	18	25	26
Max. Permissible Thrust Load (kN)	I & O type	1.33	1.51	1.63	1.99	2.56	3.34	3.34
D	I & O type	20	22	24	27	29	31	32
D <sub>1</sub>	I & O type	8.5	11	13	15	17	18.5	19.5
N / n	I & O type	4 / 0.5	5 / 0.5	5 / 0.5	6 / 1	6 / 1	7 / 1.2	7 / 1.2

- Keyway is NOT available for SPAA series.
- Surface treatment may not be applied on inner surface of Pulley's body.

### How to Order

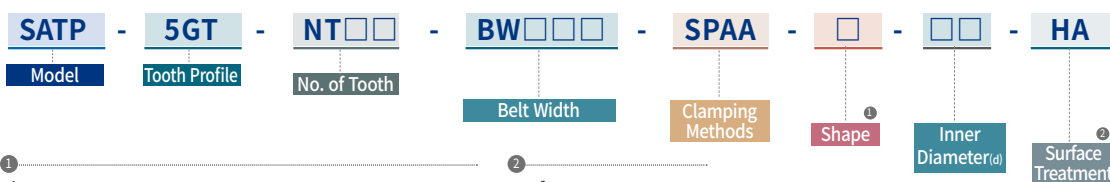

- 1 Shape
- I Flange part of A.P.Lock and Taper bushing is located inside
  - O Flange part of A.P.Lock and Taper bushing is located outside

- 2 Surface Treatment
- HA Hard Anodizing
  - WA White Anodizing

# SATP-5GT SERIES : SPAS

## High Strength Aluminum Alloy Timing Pulley

+ A.P.LOCK (Steel) Mounted Type

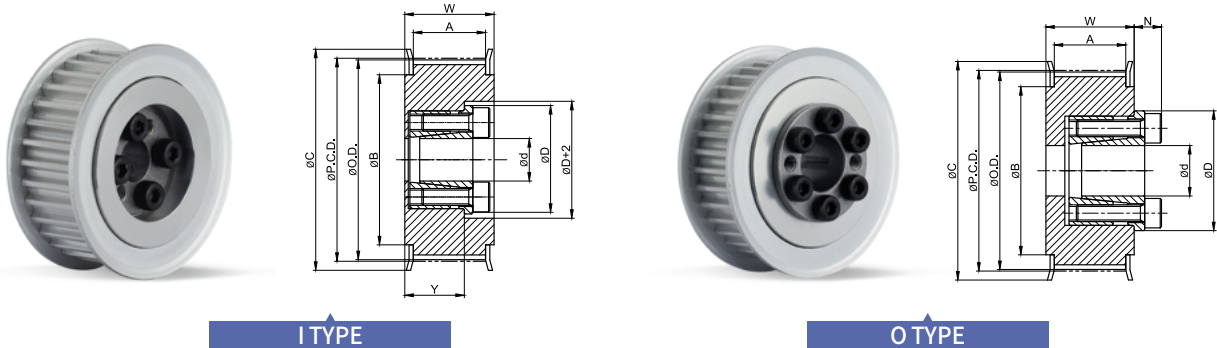

I TYPE

O TYPE

### Dimensions / Performance

#### TIMING PULLEY

(Unit:mm)

TYPE	NT	P.C.D.	O.D.	C	B	ID Range (I type)		ID Range (O type)	
						BW150 (A:16.3, W:20)	BW120 (A:13.3, W:17)	BW150 (A:16.3, W:20)	BW150 (A:16.3, W:20)
SATP-5GT SPAS	24	38.20	37.06	42	30	8	8	8	8
	25	39.79	38.65	43	32	8	8	8	8
	26	41.38	40.24	45	33	8, 10	8, 10	8, 10	8, 10
	28	44.56	43.42	48	36	8, 10	8, 10	8, 10	8, 10
	30	47.75	46.61	51	39	10	10	10	10
	32	50.93	49.79	55	42	10	10 ~ 14	10 ~ 14	10 ~ 14
	34	54.11	52.97	58	46	10	10 ~ 14	10 ~ 16	10 ~ 16
	36	57.30	56.16	61	49	10	10 ~ 14	10 ~ 16	10 ~ 16
	40	63.66	62.52	67	55	10	10 ~ 14	10 ~ 19	10 ~ 19
	44	70.03	68.89	74	62	-	12 ~ 14	12 ~ 19	12 ~ 19
	48	76.39	75.25	80	68	-	12 ~ 14	12 ~ 19	12 ~ 19
	50	79.58	78.44	83	71	-	12 ~ 14	12 ~ 19	12 ~ 19
60	95.49	94.35	99	87	-	12 ~ 14	12 ~ 19	12 ~ 19	

- Please refer to the below table for more specific available ID(d) information.

#### A.P.LOCK

(Unit:mm)

Available ID (d)		8	10	12	14	15	16	17	18	19
Max. Permissible Torque (N·m)	I & O type	22	25	50	65	70	75	110	115	120
Max. Permissible Thrust Load (kN)	I & O type	5.6	5.6	5.6	9.5	9.5	9.5	12.6	12.6	12.6
D	I & O type	23.5	25.5	28.5	30.5	31.5	33	33.5	34.5	35.5
N	I & O type	6	6	6.5	6.5	6.5	6.5	6.5	6.5	6.5

- Keyway is **NOT** available for SPAS series.
- Surface treatment may not be applied on inner surface of Pulley's body.

### How to Order

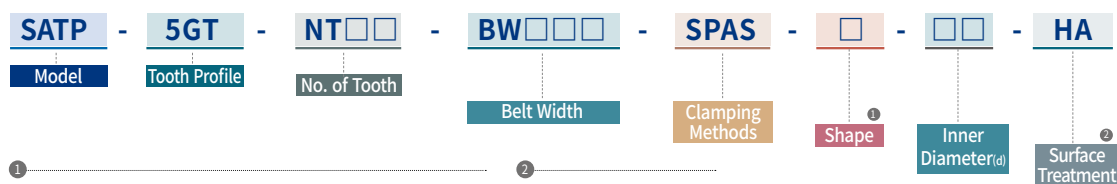

① Shape

- I Flange part of A.P.Lock and Taper bushing is located inside
- O Flange part of A.P.Lock and Taper bushing is located outside

② Surface Treatment

- HA Hard Anodizing
- WA White Anodizing

# SATP-5GT SERIES : SPB

## High Strength Aluminum Alloy Timing Pulley

+ Taper Bushing (Steel) Mounted Type

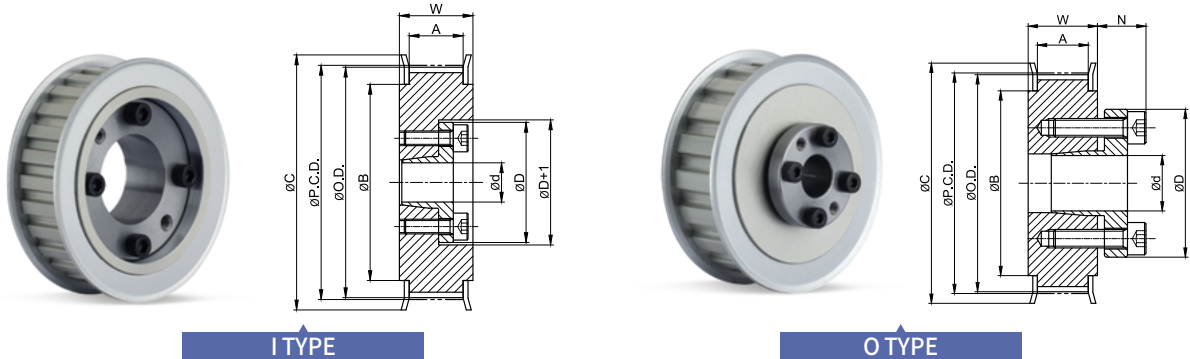

### Dimensions / Performance

**TIMING PULLEY**

(Unit:mm)

TYPE	NT	P.C.D.	O.D.	C	B	ID Range (I type)		ID Range (O type)	
						BW120 (A:13.3, W:17)	BW150 (A:16.3, W:20)	BW120 (A:13.3, W:17)	BW150 (A:16.3, W:20)
SATP-5GT SPB	22	35.01	33.87	39	27	-	-	8	-
	24	38.20	37.06	42	30	8	8	8, 10	10
	25	39.79	38.65	43	32	8	8	8, 10	10
	26	41.38	40.24	45	33	8	8 ~ 10	8 ~ 12	10 ~ 12
	28	44.56	43.42	48	36	8	8 ~ 12	8 ~ 12	10 ~ 12
	30	47.75	46.61	51	39	-	10 ~ 12	10 ~ 15	10 ~ 15
	32	50.93	49.79	55	42	-	10 ~ 12	10 ~ 17	10 ~ 17
	34	54.11	52.97	58	46	-	10 ~ 12	10 ~ 17	10 ~ 17
	36	57.30	56.16	61	49	-	10 ~ 12	10 ~ 17	10 ~ 17
	40	63.66	62.52	67	55	-	10 ~ 12	10 ~ 17	10 ~ 17
	44	70.03	68.89	74	62	-	12	12 ~ 25	12 ~ 25
	48	76.39	75.25	80	68	-	12	12 ~ 28	12 ~ 28
	50	79.58	78.44	83	71	-	12	12 ~ 32	12 ~ 32
60	95.49	94.35	99	87	-	12	12 ~ 32	12 ~ 35	

• Please refer to the below table for more specific available ID(d) information.

**TAPER BUSHING**

(Unit:mm)

Available ID (d)		8	10	11	12	14	15	16	17	18	19	20	22	24	25	28	30	32	35	
Max. Permissible Torque (N·m)	I type	8.5	18	20	23															
	O type	16	39	43	48	73	78	83	88	154	163	171	186	206	216	353	382	412	451	
Max. Permissible Thrust Load (kN)	I type	2.12	3.59	3.63	3.76															
	O type	5.34	5.34	5.34	5.34	5.34	5.34	5.34	5.34	8.74	8.74	8.74	8.74	8.74	8.74	8.74	8.74	8.74	8.74	
D	I type	24.5	29	30	31															
	O type	25.5	30	31	32	35	36	37	38	43	45	46	48	50	52	54	57	59	63	
N	O type	8.5	10.5	10.5	10.5	12	12	13	13	14	14	14	14	14	14	15.5	15.5	16.5	16.5	

- Keyway is **NOT** available for SPB series.
- Surface treatment may not be applied on inner surface of Pulley's body.

### How to Order

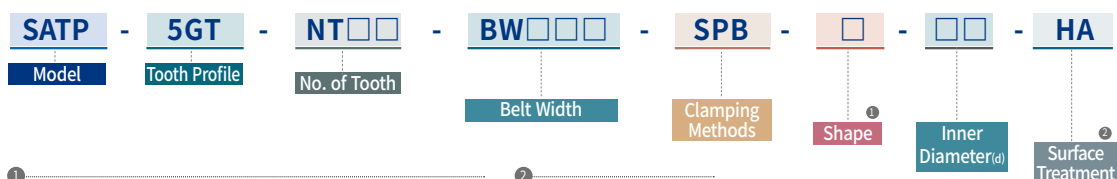

- ① Shape
- I Flange part of A.P.Lock and Taper bushing is located inside
  - O Flange part of A.P.Lock and Taper bushing is located outside

- ② Surface Treatment
- HA Hard Anodizing
  - WA White Anodizing

# SATP-5GT SERIES : SC

High Strength Aluminum Alloy Timing Pulley  
Side-clamp (High Strength Aluminum Alloy) Type

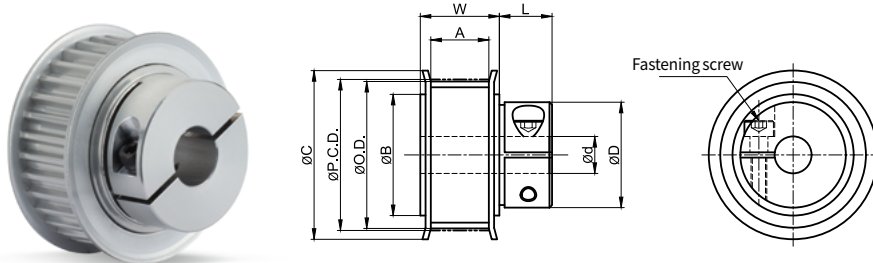

## Dimensions/Performance

### TIMING PULLEY

(Unit:mm)

TYPE	NT	P.C.D.	O.D.	C	B	D	L	Fastening Screw		ID Range	
								Size	Fastening Torque(N·m)	BW120 (A:13.3, W:17)	BW150 (A:16.3, W:20)
SATP-5GT SC	24	38.20	37.06	42	30	26	12.5	M3X10	1.5	8, 10	8, 10
	25	39.79	38.65	43	32	26	12.5	M3X10	1.5	8, 10	8, 10
	26	41.38	40.24	45	33	31	14	M4X14	3.5	8, 10	8, 10
	28	44.56	43.42	48	36	31	14	M4X14	3.5	8, 10	8, 10
	30	47.75	46.61	51	39	31	14	M4X14	3.5	10	10
	32	50.93	49.79	55	42	36	14	M4X14	3.5	10 ~ 14	10 ~ 14
	34	54.11	52.97	58	46	41	15.5	M5X16	6	10 ~ 16	10 ~ 16
	36	57.30	56.16	61	49	41	15.5	M5X16	6	10 ~ 16	10 ~ 16
	40	63.66	62.52	67	55	46	15.5	M5X16	6	10 ~ 19	10 ~ 19
	44	70.03	68.89	74	62	46	15.5	M5X16	6	12 ~ 19	12 ~ 19
						55	16.5	M6X20	12	20 ~ 24	20 ~ 24
	48	76.39	75.25	80	68	46	15.5	M5X16	6	12 ~ 19	12 ~ 19
						55	16.5	M6X20	12	20 ~ 25	20 ~ 25
	50	79.58	78.44	83	71	46	15.5	M5X16	6	12 ~ 19	12 ~ 19
						55	16.5	M6X20	12	20 ~ 25	20 ~ 25
60	95.49	94.35	99	87	46	15.5	M5X16	6	12 ~ 19	12 ~ 19	
					55	16.5	M6X20	12	20 ~ 25	20 ~ 25	

- Keyway is available for SC series.
- Surface treatment may not be applied on inner surface of Pulley's body.

## Slip Torque (N·m) by Inner diameters

ID Range (d)	8	10	11	12	13	14	15	16	17	18	19	20	21	22	23	24	25
Slip Torque (N·m)	2.6	2.6	2.6	2.6	2.6	7.6	7.6	7.6	7.6	7.6	7.6	48	48	66	66	95	95

## How to Order

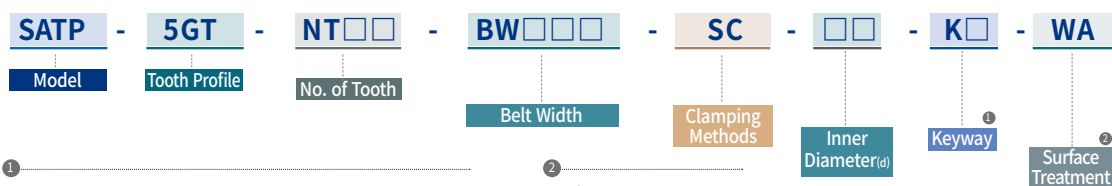

① Keyway  
No mark No Keyway  
K(b size) Keyway processed according to the indicated b size.

② Surface Treatment  
WA White Anodizing



# SATP-5GT SERIES : IDTS

## High Strength Aluminum Alloy Timing Pulley

+ Bearing Mounted Type (Both sides bearing)

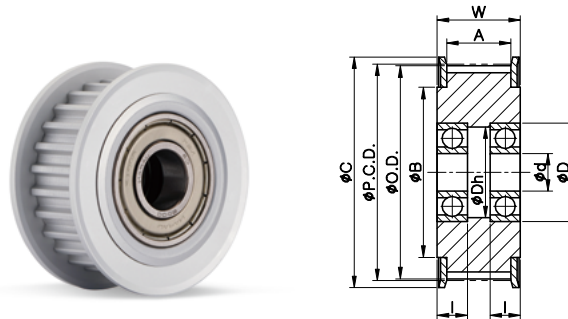

IDTS TYPE (Bearing 2 pcs.)

### Dimensions / Performance

#### TIMING PULLEY

(Unit:mm)

TYPE	NT	P.C.D.	O.D.	C	B	Bearing	D	Dh	I	ID (d) IDTS(2 pcs)	
										BW120 (A:13.3, W:17)	BW150 (A:16.3, W:20)
SATP-5GT IDTS	20	31.83	30.87	36	24	698ZZ	19	16.5	6	8	8
	22	35.01	34.05	40	27	608ZZ	22	19.5	7	-	8
						698ZZ	19	16.5	6	8	-
	24	38.20	37.24	45	30	6900ZZ	22	19.5	6	10	-
						608ZZ	22	19.5	7	-	8
						698ZZ	19	16.5	6	8	-
						6900ZZ	22	19.5	6	10	-
	25	39.79	38.83	45	30	6901ZZ	24	22	6	12	12
						696ZZ	15	13	5	6	6
						608ZZ	22	19.5	7	-	8
						698ZZ	19	16.5	6	8	-
	26	41.38	40.42	48	35	6900ZZ	22	19.5	6	10	-
						6901ZZ	24	22	6	12	12
						6001ZZ	28	25	8	-	12
						6902ZZ	28	26	7	-	15
	28	44.56	43.60	48	35	6900ZZ	22	19.5	6	10	10
						6001ZZ	28	25	8	-	12
						6901ZZ	24	22	6	12	-
						6902ZZ	28	26	7	-	15
	30	47.75	46.79	52	36	6900ZZ	22	19.5	6	10	10
						6001ZZ	28	25	8	-	12
						6901ZZ	24	22	6	12	-
						6902ZZ	28	26	7	-	15
	32	50.93	49.97	55	40	6900ZZ	22	19.5	6	-	10
						6001ZZ	28	25	8	-	12
						6902ZZ	28	26	7	-	15
						6804ZZ	32	29	7	-	20
	36	57.30	56.34	61	45	6900ZZ	22	19.5	6	-	10
						6001ZZ	28	25	8	-	12
						6902ZZ	28	26	7	-	15
						6804ZZ	32	29	7	-	20
	40	63.66	62.70	67	50	6900ZZ	22	19.5	6	-	10
						6002ZZ	32	29	9	-	15
						6804ZZ	32	29	7	-	20

### How to Order

<b>SATP</b>	-	<b>5GT</b>	-	<b>NT</b> □□	-	<b>BW</b> □□□	-	<b>IDTS</b>	-	□□	-	<b>WA</b>
Model		Tooth Profile		No. of Tooth		Belt Width		Bearing Arrangement		Inner Diameter (d)		Surface Treatment
① Surface Treatment HA Hard Anodizing WA White Anodizing												

# SATP-8YU SERIES



High Strength Aluminum Alloy Timing Pulley  
+ A.P.LOCK (High Strength Aluminum Alloy) Mounted Type

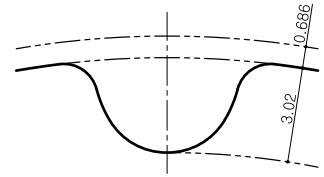

Tooth Profile: 8YU / Pitch: 8mm

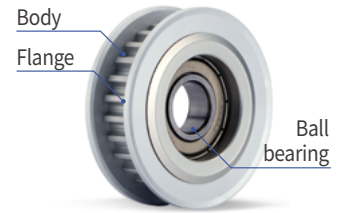
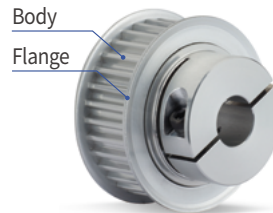
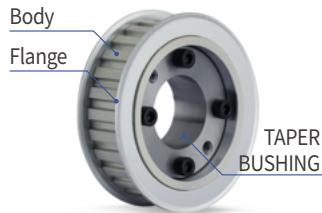
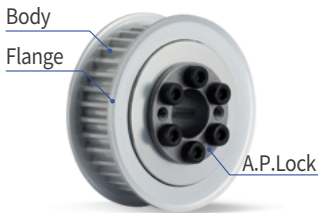

A.P.LOCK Type (SPA□)

TAPER BUSHING Type (SPB)

SIDE-CLAMP Type (SC)

IDLER Type (ID□□)

## Structure and Material

Clamping methods		Category	Pulley (Body/Flange)	A.P.LOCK	TAPER BUSHING	Fastening Screw
SPAS	Material		High Strength Aluminum Alloy	Steel	-	SCM435
	Surface Treatment		Anodizing (White/Hard)	-	-	Black Oxide
SPB	Material		High Strength Aluminum Alloy	-	Steel	SCM435
	Surface Treatment		Anodizing (White/Hard)	-	-	Black Oxide
SC	Material		High Strength Aluminum Alloy	-	-	SCM435
	Surface Treatment		Anodizing (White)	-	-	Black Oxide
ID□□	IDOC		Material	-	-	-
	IDTC		High Strength Aluminum Alloy	-	-	-
	IDTS		Surface Treatment	-	-	-
				-	-	-

## Standard Dimensions Range

Clamping Methods	OD (mm)	No. of Tooth (ea)	Belt Width (mm)
SPAS	50.93 ~ 152.79	20 ~ 60	15, 20, 25
SPB	50.93 ~ 152.79	20 ~ 60	15, 20, 25
SC	50.93 ~ 91.67	20 ~ 36	15, 25
ID□□	IDOC	50.93 ~ 101.86	20 ~ 40
	IDTC	50.93 ~ 101.86	20 ~ 40
	IDTS	56.02 ~ 101.86	22 ~ 40

## Clamping Methods

SPAA	A.P.Lock (High Strength Aluminum Alloy)	X	
SPAS	A.P.Lock (Steel)	○	
SPB	Taper Bushing	○	
SC	Side-clamp (High Strength Aluminum Alloy)	General	○
		With Keyway	○
IDOC	IDLER	Center bearing (1pc)	○
IDTC		Center bearing (2pcs)	○
IDTS		Both sides bearing (2pcs)	○

## How to Order

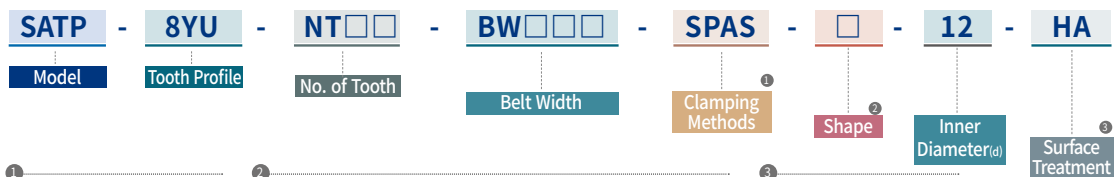

- ① Clamping Methods
- SPAS A.P.Lock (Steel)
  - SPB Taper Bushing
  - SC Side-clamp
  - ID□□ IDLER Type

- ② Shape
- I Flange part of A.P.Lock and Taper bushing is located inside
  - O Flange part of A.P.Lock and Taper bushing is located outside

- ③ Surface Treatment
- HA Hard Anodizing
  - WA White Anodizing

※ For SC clamping type, only white anodizing (WA) surface treatment is available.

# SATP-8YU SERIES : SPAS

## High Strength Aluminum Alloy Timing Pulley

+ A.P.LOCK (Steel) Mounted Type

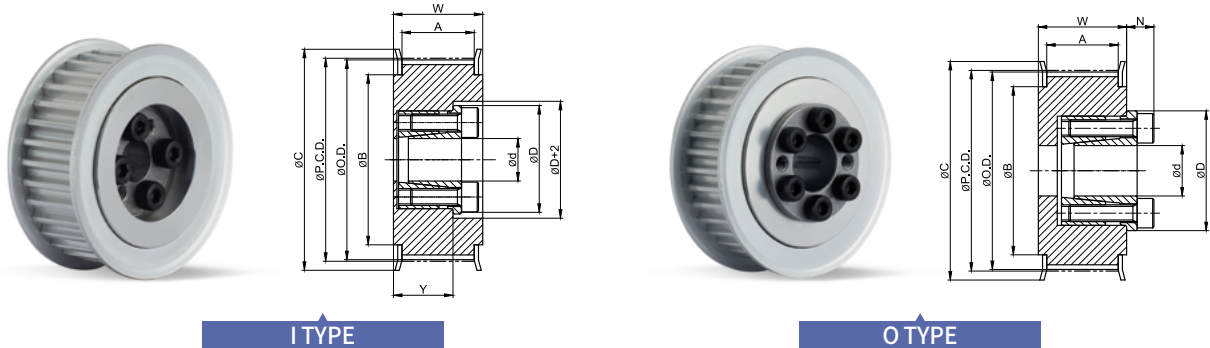

### Dimensions / Performance

#### TIMING PULLEY

(Unit:mm)

TYPE	NT	P.C.D.	O.D.	C	B	ID Range (I type)		ID Range (O type)		
						BW200 (A:21.7, W:28)	BW250 (A:26.7, W:33)	BW150 (A:16.7, W:23)	BW200 (A:21.7, W:28)	BW250 (A:26.7, W:33)
SATP-8YU SPAS	20	50.93	49.56	62	40	12, 14	12, 14	12, 14	12, 14	12, 14
	22	56.02	54.65	64	45	12 ~ 16	12 ~ 16	12 ~ 16	12 ~ 16	12 ~ 16
	24	61.12	59.75	70	50	14 ~ 19	12 ~ 19	12 ~ 19	12 ~ 19	12 ~ 19
	25	63.66	62.29	72	52	14 ~ 19	12 ~ 20	12 ~ 20	12 ~ 20	12 ~ 20
	26	66.21	64.84	75	54	14 ~ 19	14 ~ 22	14 ~ 22	14 ~ 22	14 ~ 22
	28	71.30	69.93	80	59	16 ~ 19	14 ~ 22	14 ~ 22	14 ~ 22	14 ~ 22
	30	76.39	75.02	85	64	16 ~ 19	14 ~ 28	14 ~ 22	14 ~ 28	14 ~ 28
	32	81.49	80.12	90	69	16 ~ 19	14 ~ 28	14 ~ 22	14 ~ 28	14 ~ 28
	34	86.58	85.21	95	74	16 ~ 19	16 ~ 32	16 ~ 22	16 ~ 32	16 ~ 32
	36	91.67	90.30	100	79	16 ~ 19	16 ~ 32	16 ~ 22	16 ~ 32	16 ~ 32
	38	96.77	95.40	105	84	16 ~ 19	16 ~ 32	16 ~ 22	16 ~ 32	16 ~ 32
	40	101.86	100.49	110	89	-	20 ~ 32	20, 22	20 ~ 35	20 ~ 35
	44	112.05	110.68	121	99	-	20 ~ 32	20, 22	20 ~ 35	20 ~ 35
	48	122.23	120.86	131	109	-	20 ~ 32	20, 22	20 ~ 35	20 ~ 45
	50	127.32	125.95	136	114	-	20 ~ 32	20, 22	20 ~ 35	20 ~ 50
60	152.79	151.42	161	140	-	20 ~ 32	20, 22	20 ~ 35	20 ~ 50	

- Please refer to the below table for more specific available ID(d) information.

#### A.P.LOCK

(Unit:mm)

Available ID (d)		12	14	15	16	17	18	19	20	22	24	25	28	30	32	35	40	45	50
Max. Permissible Torque (N·m)	I & O type	50	65	70	75	110	115	120	220	290	320	350	380	410	440	720	810	1,200	1,500
Max. Permissible Thrust Load (kN)	I & O type	5.6	9.5	9.5	9.5	12.6	12.6	12.6	21.6	26	26	27.2	27	27	27	41.1	40.2	52.9	56.3
D	I & O type	28.5	30.5	31.5	33	33.5	34.5	35.5	42	44	46	47	50	52	54	62	67	72	77
N	I & O type	6.5	6.5	6.5	6.5	6.5	6.5	6.5	8	8	8	8	8.5	8.5	8.5	10	10	10	10.5

- Keyway is **NOT** available for SPAS series.
- Surface treatment may not be applied on inner surface of Pulley's body.

### How to Order

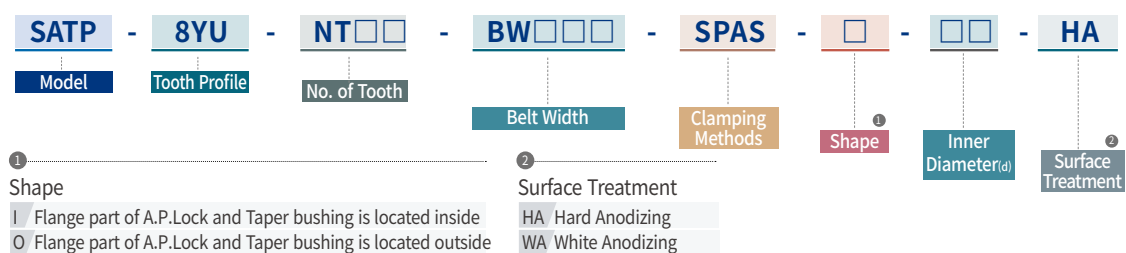

# SATP-8YU SERIES : SPB

## High Strength Aluminum Alloy Timing Pulley

+ Taper Bushing (Steel) Mounted Type

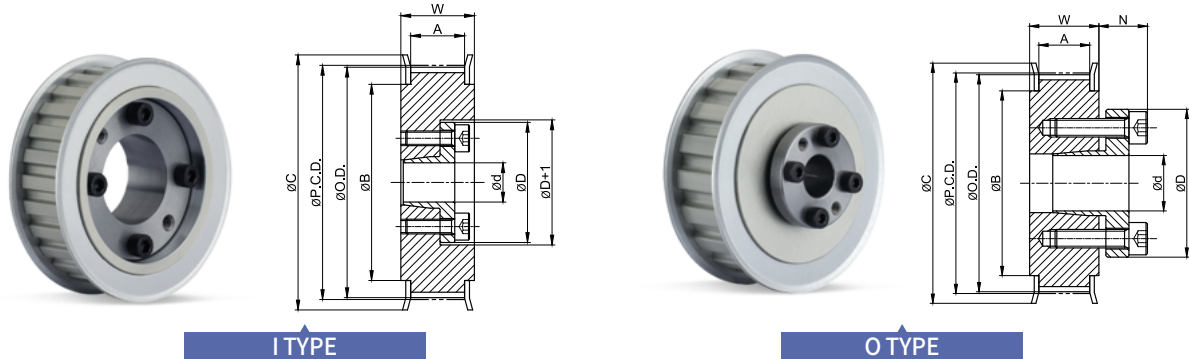

### Dimensions / Performance

**TIMING PULLEY**

(Unit:mm)

TYPE	NT	P.C.D.	O.D.	C	B	ID Range (I type)			ID Range (O type)		
						BW150 (A:16.7, W:23)	BW200 (A:21.7, W:28)	BW250 (A:26.7, W:33)	BW150 (A:16.7, W:23)	BW200 (A:21.7, W:28)	BW250 (A:26.7, W:33)
SATP-8YU SPB	20	50.93	49.56	62	40	12	12	12 ~ 15	12 ~ 17	12 ~ 17	12 ~ 17
	22	56.02	54.65	64	45	12	12 ~ 17	12 ~ 17	12 ~ 17	12 ~ 17	12 ~ 17
	24	61.12	59.75	70	50	12	12 ~ 17	12 ~ 17	12 ~ 17	12 ~ 17	12 ~ 17
	25	63.66	62.29	72	52	12	12 ~ 22	12 ~ 20	12 ~ 20	12 ~ 20	12 ~ 20
	26	66.21	64.84	75	54	-	14 ~ 22	14 ~ 20	14 ~ 24	14 ~ 24	14 ~ 24
	28	71.30	69.93	80	59	-	16 ~ 28	14 ~ 25	14 ~ 25	14 ~ 25	14 ~ 25
	30	76.39	75.02	85	64	-	16 ~ 32	14 ~ 32	14 ~ 32	14 ~ 32	14 ~ 32
	32	81.49	80.12	90	69	-	20 ~ 35	14 ~ 32	14 ~ 32	14 ~ 32	14 ~ 32
	34	86.58	85.21	95	74	-	20 ~ 35	16 ~ 35	16 ~ 35	16 ~ 35	16 ~ 35
	36	91.67	90.30	100	79	-	20 ~ 35	16 ~ 35	16 ~ 35	16 ~ 35	16 ~ 35
	38	96.77	95.40	105	84	-	20 ~ 35	20 ~ 35	16 ~ 35	16 ~ 35	16 ~ 35
	40	101.86	100.49	110	89	-	20 ~ 35	20 ~ 35	20 ~ 35	20 ~ 35	20 ~ 35
	44	112.05	110.68	121	99	-	20 ~ 35	20 ~ 35	20 ~ 35	20 ~ 35	20 ~ 35
	48	122.23	120.86	131	109	-	20 ~ 35	20 ~ 35	20 ~ 35	20 ~ 35	20 ~ 35
	50	127.32	125.95	136	114	-	20 ~ 35	20 ~ 35	20 ~ 35	20 ~ 35	20 ~ 35
60	152.79	151.42	161	140	-	20 ~ 35	20 ~ 35	20 ~ 35	20 ~ 35	20 ~ 35	

- Please refer to the below table for more specific available ID(d) information.
- Due to structural reasons, the following I type ID ranges (from 12 to 30 (BW250)) use O type taper bushings as an exception.

**TAPER BUSHING**

(Unit:mm)

Available ID (d)		12	14	15	16	17	18	19	20	22	24	25	28	30	32	35
Max. Permissible Torque (N·m)	I type	23	37	39	42	45	48	49	97	110	121	124	141	149	163	173
	O type	48	73	78	83	88	154	163	171	186	206	216	353	382	412	451
Max. Permissible Thrust Load (kN)	I type	3.76	5.21	5.1	5.17	5.23	5.28	5.12	9.68	9.98	10	9.9	10	9.89	10.12	9.88
	O type	5.34	5.34	5.34	5.34	5.34	8.74	8.74	8.74	8.74	8.74	8.74	8.74	8.74	8.74	8.74
D	I type	31	36	37	38	39	40	42	46	47	49	51	53	56	58	61
	O type	32	35	36	37	38	43	45	46	48	50	52	54	57	59	63
N	I type	10.5	12	12	13	13	14	14	14	14	14	14	15.5	15.5	16.5	16.5
	O type	10.5	12	12	13	13	14	14	14	14	14	14	15.5	15.5	16.5	16.5

- Keyway is **NOT** available for SPB series.
- Surface treatment may not be applied on inner surface of Pulley's body.

### How to Order

**SATP** - **8YU** - **NT**□□ - **BW**□□□ - **SPB** - □ - □□ - **HA**

Model      Tooth Profile      No. of Tooth      Belt Width      Clamping Methods      Shape ①      Inner Diameter(d)      Surface Treatment ②

① Shape  
 I Flange part of A.P.Lock and Taper bushing is located inside  
 O Flange part of A.P.Lock and Taper bushing is located outside

② Surface Treatment  
 HA Hard Anodizing  
 WA White Anodizing

# SATP-8YU SERIES : SC

## High Strength Aluminum Alloy Timing Pulley

+ Side-clamp (High Strength Aluminum Alloy) Type

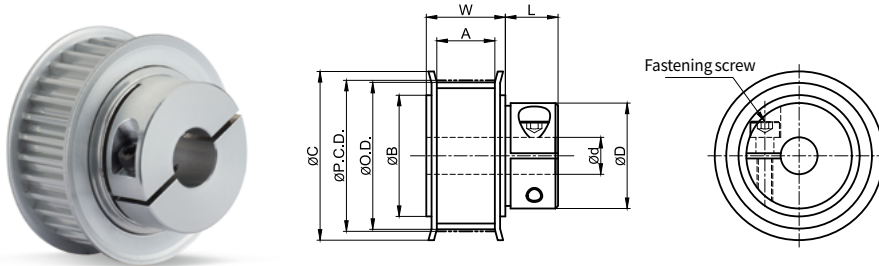

### Dimensions / Performance

#### TIMING PULLEY

(Unit:mm)

TYPE	NT	P.C.D.	O.D.	C	B	D	L	Fastening Screw		ID Range	
								Size	Fastening Torque(N·m)	BW150 (A:16.7, W:23)	BW250 (A:26.7, W:33)
SATP-8YU SC	20	50.93	49.56	62	40	36	14	M4X14	3.5	12 ~ 14	12 ~ 14
	22	56.02	54.65	64	45	41	16	M5X16	6	12 ~ 16	12 ~ 16
	24	61.12	59.75	70	50	46	16	M5X16	6	12 ~ 19	12 ~ 19
	25	63.66	62.29	72	52	46	16	M5X16	6	12 ~ 19	12 ~ 19
	28	71.3	69.93	80	59	46	16	M5X16	6	15 ~ 19	15 ~ 19
						55	17	M6X20	12	20 ~ 25	20 ~ 25
	30	76.39	75.02	85	64	46	16	M5X16	6	15 ~ 19	15 ~ 19
						55	17	M6X20	12	20 ~ 25	20 ~ 25
	32	81.49	80.12	90	69	46	16	M5X16	6	18, 19	18, 19
						55	17	M6X20	12	20 ~ 25	20 ~ 25
	34	86.58	85.21	95	74	46	16	M5X16	6	18, 19	18, 19
						55	17	M6X20	12	20 ~ 25	20 ~ 25
36	91.67	90.3	100	79	46	16	M5X16	6	18, 19	18, 19	
					55	17	M6X20	12	20 ~ 25	20 ~ 25	

- Keyway is available for SC series.
- Surface treatment may not be applied on inner surface of Pulley's body.

### Slip Torque (N·m) by Inner diameters

ID Range (d)	12	13	14	15	16	17	18	19	20	21	22	23	24	25
Slip Torque (N·m)	2.6	2.6	7.6	7.6	7.6	7.6	7.6	7.6	48	48	66	66	95	95

### How to Order

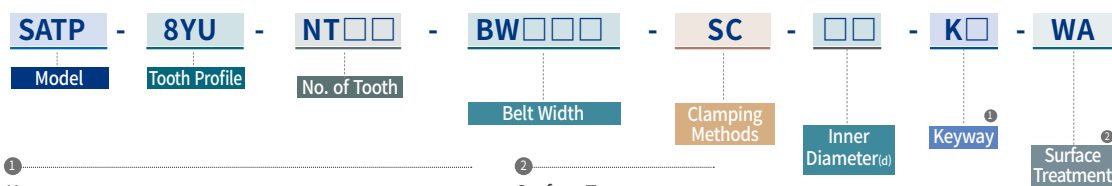

- ① Keyway  
 No mark No Keyway  
 K(b size) Keyway processed according to the indicated b size.

- ② Surface Treatment  
 WA White Anodizing

# SATP-8YU SERIES : IDOC, IDTC

High Strength Aluminum Alloy Timing Pulley

+ Bearing Mounted Type (Center bearing)

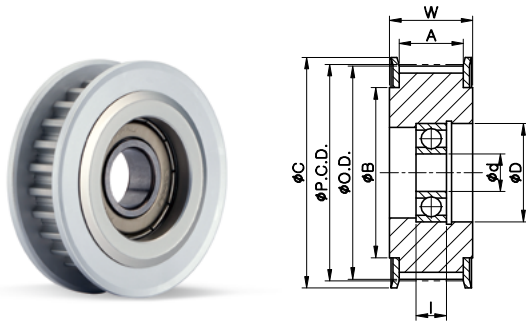

IDOC TYPE (Bearing 1 pc.)

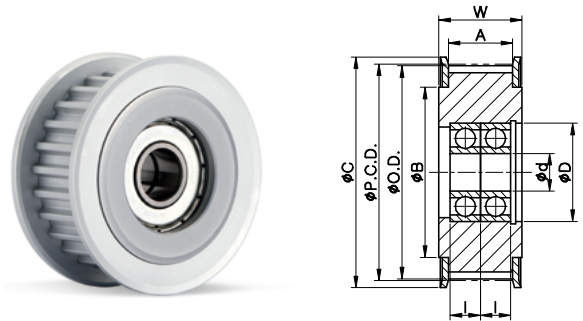

IDTC TYPE (Bearing 2 pcs.)

## Dimensions / Performance

### TIMING PULLEY

(Unit:mm)

TYPE	NT	P.C.D.	O.D.	C	B	Bearing	D	I	ID (d)	ID (d)
									IDOC(1 pc) BW150 (A:16.3, W:20)	IDTC(2 pcs) BW250 (A:26.7, W:33)
SATP-8YU IDOC IDTC	20	50.93	49.56	58	40	6201ZZ	32	10	12	12
						6202ZZ	35	11	15	15
	22	56.02	54.65	61	45	6201ZZ	32	10	12	12
						6202ZZ	35	11	15	15
	24	61.12	59.74	67	50	6201ZZ	32	10	12	12
						6202ZZ	35	11	15	15
						6004ZZ	42	12	20	-
						6904ZZ	37	9	-	20
	25	63.66	62.29	70	56	6202ZZ	35	11	15	15
						6004ZZ	42	12	20	20
	26	66.21	64.84	74	58	6202ZZ	35	11	15	15
						6202ZZ	35	11	15	15
	30	76.39	75.02	87	67	6202ZZ	35	11	15	15
						6004ZZ	42	12	-	20
						6204ZZ	47	14	20	-
						6005ZZ	47	12	25	25
32	81.49	80.12	87	67	6204ZZ	47	14	20	-	
					6005ZZ	47	12	25	-	
34	86.58	85.21	95	75	6204ZZ	47	14	20	-	
36	91.67	90.30	99	80	6005ZZ	47	12	25	-	
40	101.86	100.49	111	90	6005ZZ	47	12	25	-	

## How to Order

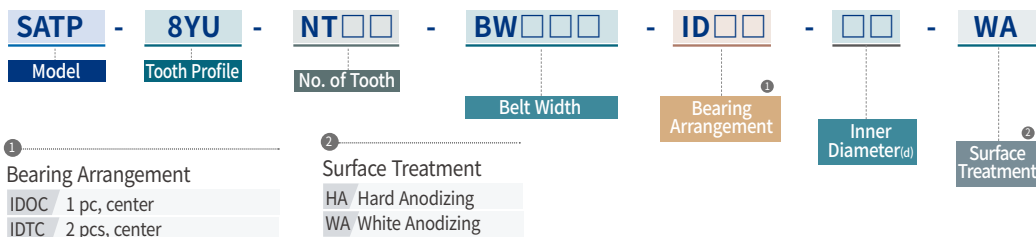

# SATP-8YU SERIES : IDTS

## High Strength Aluminum Alloy Timing Pulley

+ Bearing Mounted Type (Both sides bearing)

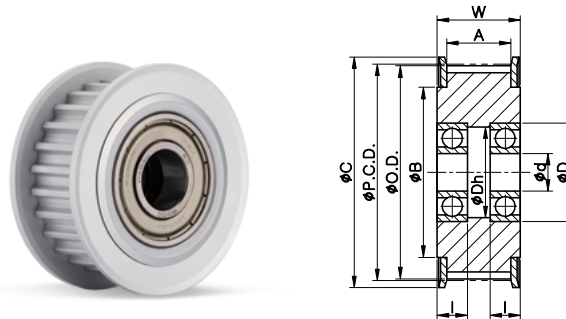

IDTS TYPE (Bearing 2 pcs.)

### Dimensions / Performance

#### TIMING PULLEY

(Unit:mm)

TYPE	NT	P.C.D.	O.D.	C	B	Bearing	D	Dh	l	ID (d) IDTS(2 pcs)	
										BW150 (A:16.3, W:20)	BW250 (A:26.7, W:33)
SATP-8YU IDTS	22	56.02	54.65	61	45	6001ZZ	28	25	8	12	-
						6002ZZ	32	29	9	15	-
						6202ZZ	35	30	11	-	15
	24	61.12	59.74	67	50	6201ZZ	32	27	10	-	12
						6904ZZ	37	32	9	20	20
	25	63.66	62.29	70	56	6201ZZ	32	27	10	-	12
						6204ZZ	47	41	14	-	20
						6904ZZ	37	32	9	20	-
	26	66.21	64.84	74	58	6001ZZ	28	25	8	12	12
						6202ZZ	35	30	11	-	15
	28	71.30	69.93	80	60	6002ZZ	32	29	9	15	15
						6004ZZ	42	37	12	-	20
	30	76.39	75.02	87	67	6005ZZ	47	43	12	-	25
						6204ZZ	47	41	14	-	20
	32	81.49	80.12	87	67	6005ZZ	47	43	12	-	25
						6204ZZ	47	41	14	-	20
34	86.58	85.21	95	75	6204ZZ	47	41	14	-	20	
36	91.67	90.30	99	80	6005ZZ	47	43	12	-	25	
40	101.86	100.49	111	90	6005ZZ	47	43	12	-	25	

### How to Order

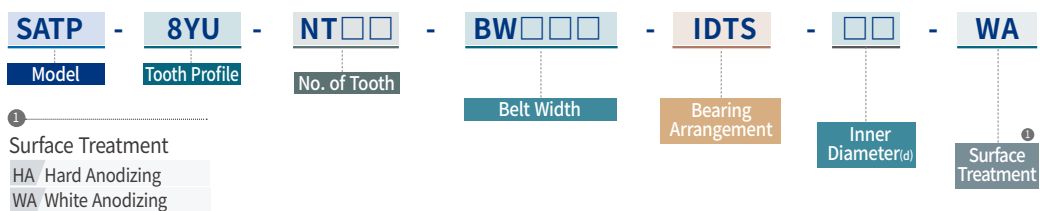

# A.P. LOCK

## (KEYLESS BUSHING)

### Overview

Index (A.P. Lock)	196p
Selection and Design Guide	197p
Installation Guide	198~199p





### Dimensions / Performance





SAPL-A Series	200~202p
SAPL-B Series	204~205p
SAPL-C Series	206~208p
SAPL-D1 Series	210~211p
SAPL-D2 Series	212~213p
SAPL-D3 Series	214~215p
SAPL-D4 Series	216~217p
SAPL-E Series	218~219p
SAPL-T Series	220~221p
SAPL-R Series	222~224p
SAPC Series	225~226p
SAPA Series	227~228p







# INDEX (A.P.LOCK)

Series	SAPL-A Series			SAPL-B Series
Model	SAPL-A	SAPL-AK	S APL-AS	SAPL-B
Material (Body)	STEEL	STEEL (Electroless Nickel Plating)	STS304	STEEL
Shape				
page	201p	202p	203p	205p

Series	SAPL-C Series			SAPL-D Series
Model	SAPL-C	SAPL-CK	SAPL-CS	SAPL-D1
Material (Body)	STEEL	STEEL (Electroless Nickel Plating)	STS304	STEEL
Shape				
page	207p	208p	209p	211p

Series	SAPL-D Series			SAPL-E Series
Model	SAPL-D2	SAPL-D3	SAPL-D4	SAPL-E
Material (Body)	STEEL	STEEL	STEEL	STEEL
Shape				
page	213p	215p	217p	219p

Series	SAPL-T Series	SAPL-R Series	SAPC Series	SAPA Series
Model	SAPL-T	SAPL-R	SAPC	SAPA
Material (Body)	STEEL	STEEL	AL-7075-T6	AL-7075-T6
Shape				
page	221p	224p	226p	228p

# A.P. LOCK OVERVIEW

## A.P.Lock - Selection and Design Guide

### Calculation of a Motor's Max. Torque

- Maximum torque is calculated by motor's rotational speed (rpm), output power and reduction ratio etc. The safety factor (in the below table) has to be considered by all means in case motor's torque information is not available.

$$T_{\max} = \frac{9554 \times P_{\max}}{N \times i} \times SF$$

$T_{\max}$  = Max. Motor Torque [N · m]  
 $P_{\max}$  = Max. Output Power [kW]  
 $N$  = Rotational Speed [rpm]  
 $i$  = Gear Reduction Ratio  
 $SF$  = Safety Factor

Load Conditions		Safety Factor (SF)
Low Inertia	At 60% (or less) of motor's rated torque	1.5~2.0
Medium Inertia	Longer acceleration/deceleration time, limited reverse motion and small impact	2.0~3.0
High Inertia	Shorter acceleration/deceleration time, frequent reverse motion and large impact	3.0~5.0

$$T_{\max} (\text{Max. Motor Torque}) < T_c (\text{Max. Permissible Torque of A.P. Lock})$$

- Max. motor torque (with SF applied) must be lower than max. permissible torque of A.P. Lock.

### Thrust Load

$$P (\text{Max. Thrust Load}) < P_t (\text{Max. Permissible Thrust Load of A.P. Lock})$$

- The thrust load on A.P. Lock's fastening area must be lower than max. permissible thrust load of A.P. Lock.

### Combined Torque and Thrust Load

- If torque and thrust load occur simultaneously, please refer to the below formula for load calculation.

$$T_{\text{comb}} = \sqrt{\left(\frac{9554 \times P_{\max}}{N}\right)^2 + \left(\frac{P \times d}{2000}\right)^2} \times SF$$

$T_{\text{comb}}$  = Combined Load [n.m]       $d$  = Shaft Diameter [mm]  
 $P_{\max}$  = Max. Motor Output Power [kW]       $P$  = Thrust Load [N]  
 $N$  = Rotational Speed [rpm]       $SF$  = Safety Factor

$$T_{\text{comb}} (\text{Combined Load}) < T_c (\text{Max. Permissible Torque of A.P. Lock})$$

- Combined Load of torque and thrust must be lower than max. permissible torque of A.P. Lock.

### Permissible Torque Variation

#### 1. Permissible Torque Increase

When several A.P. Locks are used together, permissible torque and thrust load gets increased.

※ Make sure all foreign substances must be removed from surface of the both shaft and inner part of A.P. Lock.

#### 2. Permissible Torque Decrease

When the shaft has an additional keyway, permissible torque would be decreased by appx. 20% due to reduced contact area.

### Shaft Design Guide

- Please refer to each overview pages for shaft tolerance.
- Check the strength of shaft's raw material.

$$\sigma_s > 1.2 \times P_i$$

$\sigma_s$ : Yield stress of shaft's raw material [MPa]  
 $P_i$ : Surface pressure onto shaft by A.P. Lock [MPa]

#### 3. Determine max. inner diameter of hollow shaft.

High surface pressure is delivered on the shaft. Thus, make sure the below formula is referred when the hollow shaft is designed.

$$d_i \leq d \times \sqrt{\frac{\sigma_s - 2 \times 0.8 \times P_i}{\sigma_s}}$$

$d_i$ : Inner dia. of hollow shaft       $\sigma_s$ : Yield stress of shaft's raw material [MPa]  
 $d$ : Outer dia. of hollow shaft       $P_i$ : Surface Pressure onto Shaft by A.P. Lock [MPa]

### Hub Design Guide

- Please refer to each overview pages for hub tolerance.
- Check the strength of hub's raw material.

$$\sigma_h > 1.2 \times P_o$$

$\sigma_h$ : Yield stress of hub's raw material [MPa]  
 $P_o$ : Surface pressure onto hub by A.P. Lock [MPa]

#### 3. Check the min. hub outer diameter.

You may refer to the below formula in case the material information is not available.

$$D_o \geq D_i \times \sqrt{\frac{\sigma_h + 0.8 \times P_o}{\sigma_h - 0.8 \times P_o}}$$

$D_o$ : Outer dia. of hub [mm]       $\sigma_h$ : Yield stress of hub's raw material [MPa]  
 $D_i$ : Inner dia. of hub [mm]       $P_o$ : Surface pressure onto hub by A.P. Lock [MPa]

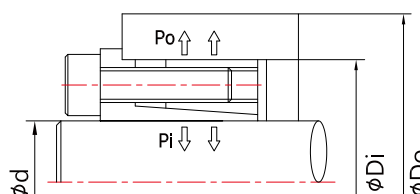

# A.P. LOCK OVERVIEW

## A.P. Lock - Installation Guide

### HOW TO INSTALL (SAPL-A, B, C, D1, D2, D3, D4, E, T Series)

1. Wipe inner surface of shaft and hub to remove dust and oil.
2. Wipe inner and outer surface of A.P. Lock.
3. Spread anti-wear hydraulic oil or grease on to inner surface of shaft and hub. (Any oil type which includes molybdenum-sulfur compounds or silicone is prohibited.)
4. Unfasten all screws and spread hydraulic oil #68 onto A.P. Lock body and taper-ring surface. (Make sure oil is not in use under vacuum environment. In this case, clamping force may be subject to change from catalog values.)
5. Interlock an A.P. Lock with shaft temporarily and insert it into the hub.
  - Make sure the corner of hub becomes properly attached to A.P. Lock's flange part.
  - Determine the relative location of shaft and hub.
  - Make sure there is bigger than 1mm of clearance between shaft-end and hub. (Otherwise, there will be problem in disassembling and it may result in shape distortion.)
  - In case A.P. Lock doesn't go into hub smoothly, try to loosen fastening screws or tapping them into hub slightly. (Make sure the force is not too strong.)

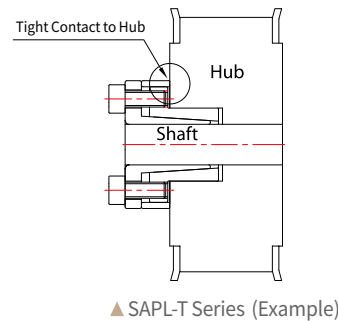
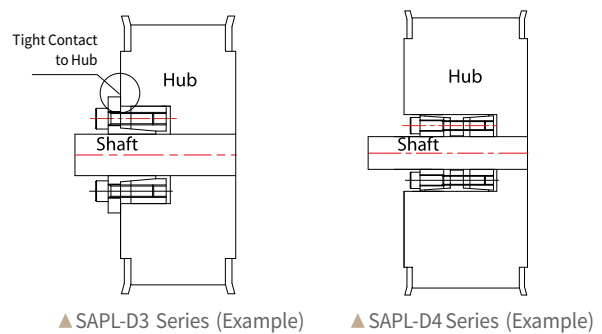
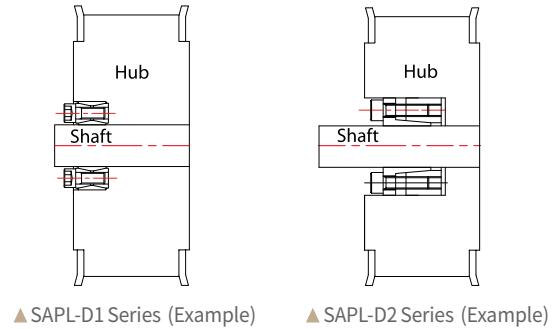
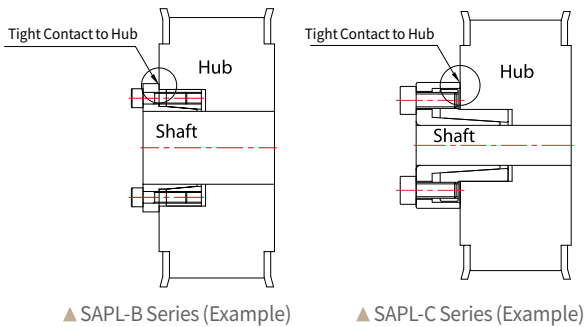
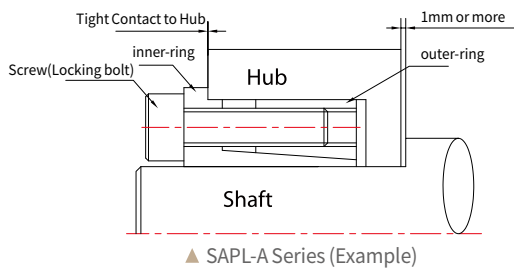

6. Fasten the screws with appropriate fastening torque in sequential order as shown on the below figure.

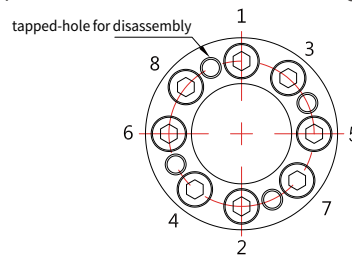

- Fasten the screws with identical torque (1/8 of fastening torque) using torque wrench.
- Make sure you fasten the screws in sequential order as shown on the above figure.
- Make sure A.P. Lock's flange part becomes properly attached to hub.
- Repeat fastening the screws with 1/4 of fastening torque. (in diagonal order)
- Repeat fastening the screws with 1/2 of fastening torque. (in diagonal order)
- Finally repeat fastening the screws with full fastening torque until screws don't rotate any longer.

# A.P. LOCK OVERVIEW

## A.P. Lock - Installation Guide

### HOW TO INSTALL (SAPC, SAPA)

1. Wipe inner surface of shaft and hub to remove dust and oil.
2. A.P. Lock which is made of aluminum alloy does not require any anti-wear hydraulic oil.
3. Interlock an A.P. Lock with shaft temporarily and insert it into the hub.

-Make sure the corner of hub becomes properly attached to A.P. Lock's flange part.

-Determine the relative location of shaft and hub using measurement tool e.g. Vernier calipers etc.

-In case A.P. Lock doesn't go into hub smoothly, try to loosen fastening screws or tapping them into hub slightly. (Make sure the force is not too strong.)

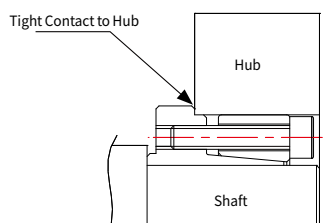

▲ SAPC Series (Example)

※ SAPA series looks identical to SAPL-A series when installed.

4. Fasten the screws with appropriate fastening torque in sequential order as shown on the below figure.

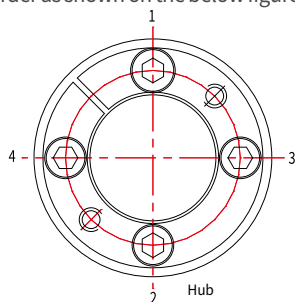

- Fasten the screws with identical torque (1/4 of fastening torque) using torque wrench.
- Make sure you fasten the screws in sequential order as shown on the above figure.
- Make sure A.P. Lock's flange part becomes properly attached to hub.
- Repeat fastening the screws with 1/2 of fastening torque. (in diagonal order)
- Finally repeat fastening the screws with full fastening torque until screws don't rotate any longer.

### HOW TO DISASSEMBLE

1. Remove external load (torque/thrust) on the shaft and hub.
2. Remove self-load of chain, belt etc.
3. Unfasten all screws in the same order when they were fastened.
4. In case A.P. Lock is not detached properly, try to disassemble using the tapped-hole for disassembly on A.P. Lock body.

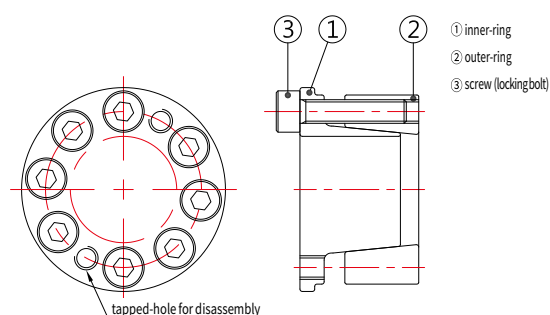

### RE-USE

- A.P. Lock can be used repeatedly.
- In case surface pressure is stronger than yield stress of shaft or hub, it may result in shape distortion of shaft or hub as well as A.P. Lock.

### CAUTIONS

1. Temperature range : - 30°C ~ + 200°C
2. Make sure the screws are fastened by torque wrench. (Please refer to "Dimensions / Performance" tables for fastening torques.
3. A.P. Lock is vulnerable at bending moment.

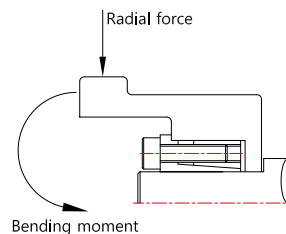

4. In case there is not enough lubrication with anti-wear hydraulic oil, transmittable torque would be decreased by appx. 25%. **(Please do not allow to use anti-wear hydraulic oil at vacuum area.)**
5. When the shaft has an additional keyway, permissible torque would be decreased by appx. 20% due to reduced contact area.

# A.P. LOCK : SAPL-A SERIES

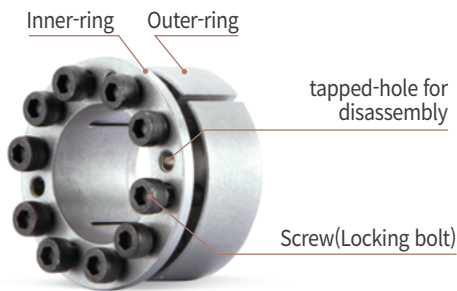

SAPL-A



SAPL-AK



SAPL-AS

## Structure and Material for SAPL-A Series

Model	Body (Inner-ring / Outer-ring)		Screw(Locking bolt)	
	Material	Surface Treatment	Material	Surface Treatment
SAPL-A	STEEL	-	SCM435	Black Oxide
SAPL-AK	STEEL	Electroless Nickel Plating	SCM435	Electroless Nickel Plating
SAPL-AS	STS304	-	STS304	-

## Product Features

- Self-centering function (prevention of slight off-center matters)
- Designed to suit relatively smaller hubs (as there is only small difference in dimension between inner(d) and outer(D) diameters, as well as its surface pressure is low)
- A wide range of standard inner diameters (from Ø5 to Ø50)
- Simple structure for easier installation & handier maintenance
- Diverse material & finish options available (e.g. stainless steel body for vacuum area, electroless nickel plating etc.)

## Principles

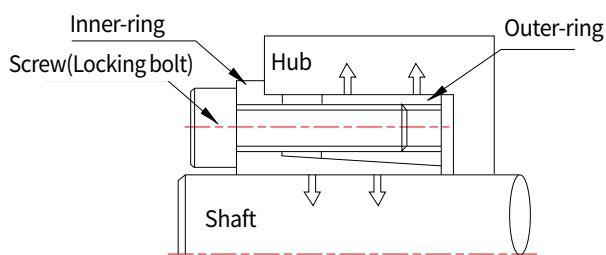

## How to Order

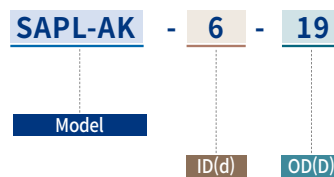

# SAPL-A SERIES : SAPL-A



## Dimensions / Performance

Model d x D	Size (±0.3mm)						Max. Permissible Torque (Tc) (N·m)	Max. Permissible Thrust Load (Pt) (kN)	Surface Pressure (MPa)		Screw(Locking bolt)			Mass(g)
	L <sub>1</sub>	L <sub>2</sub>	L <sub>3</sub>	L	D <sub>1</sub>	P.C.D			Shaft(Pi)	Hub(Po)	Size	The no. of screws	Fastening Torque (N·m)	
SAPL-A-5 x 16	8	11.2	13	16	18.5	11.7	7	2.8	249	81	M3x10	4	1.9	18
SAPL-A-6 x 19	9	12.3	14.3	18.3	21.5	14	14	4.7	318	102	M4x12	4	3.9	26
SAPL-A-6.35 x 20	9	12.3	14.3	18.3	22.5	14.4	14	4.7	301	97	M4x12	4	3.9	29
SAPL-A-7 x 21	9.3	12.6	14.6	18.6	23.5	15.5	16	5	250	100	M4x12	4	3.9	35
SAPL-A-8 x 21	9.3	12.6	14.6	18.6	23.5	15.4	22	5.6	239	107	M4x12	4	3.9	35
SAPL-A-10 x 23	9.5	12.8	14.8	18.8	25.5	17.5	25	5.6	186	96	M4x12	4	3.9	40
SAPL-A-11 x 24	10.5	13.8	15.8	19.8	26.5	18.5	30	5.6	170	92	M4x12	4	3.9	45
SAPL-A-12 x 26	10.5	15.5	18	22	28.5	20.2	50	8.4	233	115	M4x15	6	3.9	53
SAPL-A-14 x 28	10.5	15.5	18	22	30.5	22.2	65	9.5	225	120	M4x15	6	3.9	61
SAPL-A-15 x 29	11.5	16.5	19	23	31.5	23.2	70	9.5	186	106	M4x15	6	3.9	66
SAPL-A-16 x 30	12	17.1	19.6	23.6	33	24.2	75	9.5	166	98	M4x15	6	3.9	75
SAPL-A-17 x 31	12.5	17.6	20.1	24.1	33.5	25.4	110	12.6	197	121	M4x15	8	3.9	75
SAPL-A-18 x 32	12.5	17.6	20.1	24.1	34.5	26.4	115	12.6	186	118	M4x15	8	3.9	80
SAPL-A-19 x 33	12.5	17.6	20.1	24.1	35.5	27.4	120	12.6	177	114	M4x15	8	3.9	81
SAPL-A-20 x 38	15.3	21.1	24.1	29.1	42	30.8	220	21.6	234	139	M5x18	8	8.8	144
SAPL-A-22 x 40	15.3	21.1	24.1	29.1	44	32.8	290	26	256	159	M5x18	8	8.8	165
SAPL-A-24 x 42	16.3	22.1	25.1	30.1	46	34.8	320	26	217	142	M5x18	8	8.8	180
SAPL-A-25 x 43	17.3	23.1	26.1	31.1	47	35.8	350	27.2	216	137	M5x18	8	8.8	188
SAPL-A-28 x 46	17.3	23.1	26.6	31.6	50	38.8	380	27	192	127	M5x18	10	8.8	195
SAPL-A-30 x 48	17.3	23.1	26.6	31.6	52	40.8	410	27	179	122	M5x18	10	8.8	208
SAPL-A-32 x 50	18.3	24.1	27.6	32.6	54	42.8	440	27	156	110	M5x18	10	8.8	219
SAPL-A-35 x 57	19.5	26	30	36	62	48.4	720	41.1	204	138	M6x20	8	15.7	325
SAPL-A-38 x 60	20	26.5	30.5	36.5	65	51.4	770	40.2	178	125	M6x20	10	15.7	362
SAPL-A-40 x 62	20.5	27	31	37	67	53.4	810	40.2	164	118	M6x20	10	15.7	380
SAPL-A-42 x 64	20.5	27	31	37	69	55.4	850	50.2	156	114	M6x20	10	15.7	405
SAPL-A-45 x 67	21	27.5	31.5	37.5	72	58.4	1,200	52.9	186	140	M6x20	10	15.7	435
SAPL-A-48 x 70	21	27.5	32	38	75	61.4	1,200	48.2	159	123	M6x20	12	15.7	460
SAPL-A-50 x 72	21.5	28	32.5	38.5	77	63.4	1,500	56.3	173	136	M6x20	14	15.7	485

- Pt(Max. Permissible Thrust Load) indicates values at the zero(0) torque, and Tc(Max. Permissible Torque) at the zero(0) thrust load respectively. In case torque and thrust load occur simultaneously, please refer to the formula in the [Selection guide] page for combined load calculation.
- For the best performance, make sure all foreign substances e.g. corrosion, dust etc. are removed from each surface of shaft, hub, and A.P. Lock's inner and outer ring.

# SAPL-A SERIES : SAPL-AK



## Dimensions / Performance

Model d x D	Size (±0.3mm)						Max. Permissible Torque (Tc) (N·m)	Max. Permissible Thrust Load (Pt) (kN)	Surface Pressure (MPa)		Screw(Locking bolt)			Mass(g)
	L <sub>1</sub>	L <sub>2</sub>	L <sub>3</sub>	L	D <sub>1</sub>	P.C.D			Shaft(Pi)	Hub(Po)	Size	The no. of screws	Fastening Torque (N·m)	
SAPL-AK-5 x 16	8	11.2	13	16	18.5	11.7	4.6	1.8	244	51	M3x12	4	1.9	18
SAPL-AK-6 x 19	9	12.3	14.3	18.3	21.5	14	10.7	2.6	256	59	M4x12	4	3.9	26
SAPL-AK-6.35 x 20	9	12.3	14.3	18.3	22.5	14.4	10.7	2.6	270	62	M4x12	4	3.9	29
SAPL-AK-7 x 21	9.3	12.6	14.6	18.6	23.5	15.5	12.5	3	257	75	M4x12	4	3.9	35
SAPL-AK-8 x 21	9.3	12.6	14.6	18.6	23.5	15.4	16.6	4.1	244	92	M4x12	4	3.9	35
SAPL-AK-10 x 23	9.5	12.8	14.8	18.8	25.5	17.5	19.6	3.9	192	77	M4x12	4	3.9	40
SAPL-AK-11 x 24	10.5	13.8	15.8	19.8	26.5	18.5	22.5	4	174	73	M4x12	4	3.9	45
SAPL-AK-12 x 26	10.5	15.5	18	22	28.5	20.2	36.2	5.9	239	91	M4x15	6	3.9	53
SAPL-AK-14 x 28	10.5	15.5	18	22	30.5	22.2	50.9	7.2	204	84	M4x15	6	3.9	61
SAPL-AK-15 x 29	11.5	16.5	19	23	31.5	23.2	54.8	7.2	205	90	M4x15	6	3.9	66
SAPL-AK-16 x 30	12	17.1	19.6	23.6	33	24.2	58.8	7.3	193	87	M4x15	6	3.9	75
SAPL-AK-17 x 31	12.5	17.6	20.1	24.1	33.5	25.4	76.4	8.9	205	97	M4x15	8	3.9	75
SAPL-AK-18 x 32	12.5	17.6	20.1	24.1	34.5	26.4	80.3	8.9	166	93	M4x15	8	3.9	80
SAPL-AK-19 x 33	12.5	17.6	20.1	24.1	35.5	27.4	85.2	8.9	184	91	M4x15	8	3.9	81
SAPL-AK-20 x 38	15.3	21.1	24.1	29.1	42	30.8	183	18.3	213	97	M5x18	8	8.8	144
SAPL-AK-22 x 40	15.3	21.1	24.1	29.1	44	32.8	201	18.3	193	92	M5x18	8	8.8	165
SAPL-AK-24 x 42	16.3	22.1	25.1	30.1	46	34.8	252	21	121	105	M5x18	8	8.8	180
SAPL-AK-25 x 43	17.3	23.1	26.1	31.1	47	35.8	264	21.1	212	102	M5x18	8	8.8	188
SAPL-AK-28 x 46	17.3	23.1	26.6	31.6	50	38.8	295	21.1	212	107	M5x18	10	8.8	195
SAPL-AK-30 x 48	17.3	23.1	26.6	31.6	52	40.8	396	26.4	198	102	M5x18	10	8.8	208
SAPL-AK-32 x 50	18.3	24.1	27.6	32.6	54	42.8	423	26	192	103	M5x18	10	8.8	219
SAPL-AK-35 x 57	19.5	26	30	36	62	48.4	548	31.3	207	105	M6x20	8	15.7	325
SAPL-AK-38 x 60	20	26.5	30.5	36.5	65	51.4	741	39	208	110	M6x20	10	15.7	362
SAPL-AK-40 x 62	20.5	27	31	37	67	53.4	779	39	202	110	M6x20	10	15.7	380
SAPL-AK-42 x 64	20.5	27	31	37	69	55.4	823	39.2	192	106	M6x20	10	15.7	405
SAPL-AK-45 x 67	21	27.5	31.5	37.5	72	58.4	882	39.2	184	104	M6x20	10	15.7	435
SAPL-AK-48 x 70	21	27.5	32	38	75	61.4	1,117	46.5	206	118	M6x20	12	15.7	460
SAPL-AK-50 x 72	21.5	28	32.5	38.5	77	63.4	1,362	54.4	202	119	M6x20	14	15.7	485

- Pt(Max. Permissible Thrust Load) indicates values at the zero(0) torque, and Tc(Max. Permissible Torque) at the zero(0) thrust load respectively. In case torque and thrust load occur simultaneously, please refer to the formula in the [Selection guide] page for combined load calculation.
- For the best performance, make sure all foreign substances e.g. corrosion, dust etc. are removed from each surface of shaft, hub, and A.P. Lock's inner and outer ring.

# SAPL-A SERIES : SAPL-AS



## Dimensions / Performance

Model d x D	Size ( $\pm 0.3\text{mm}$ )						Max. Permissible Torque (Tc) (N·m)	Max. Permissible Thrust Load (Pt) (kN)	Surface Pressure (MPa)		Screw(Locking bolt)			Mass(g)
	L <sub>1</sub>	L <sub>2</sub>	L <sub>3</sub>	L	D <sub>1</sub>	P.C.D			Shaft(Pi)	Hub(Po)	Size	The no. of screws	Fastening Torque (N·m)	
SAPL-AS-5 x 16	8	11.2	13	16	18.5	11.7	2.8	1.1	204	42	M3x12	4	1.9	18
SAPL-AS-6 x 19	9	12.3	14.3	18.3	21.5	14	7.8	2.5	260	58	M4x12	4	3.9	26
SAPL-AS-8 x 21	9.3	12.6	14.6	18.6	23.5	15.4	10.7	2.6	196	62.6	M4x12	4	2.7	35
SAPL-AS-10 x 23	9.5	12.8	14.8	18.8	25.5	17.5	12.7	2.6	153	55.9	M4x12	4	2.7	40
SAPL-AS-11 x 24	10.5	13.8	15.8	19.8	26.5	18.5	14.7	2.6	139	53.6	M4x12	4	2.7	45
SAPL-AS-12 x 26	10.5	15.5	18	22	28.5	20.2	24.5	4	191	67.1	M4x15	6	2.7	53
SAPL-AS-14 x 28	10.5	15.5	18	22	30.5	22.2	28.4	4	164	62.3	M4x15	6	2.7	61
SAPL-AS-15 x 29	11.5	16.5	19	23	31.5	23.2	30.4	4	136	55	M4x15	6	2.7	66
SAPL-AS-16 x 30	12	17.1	19.6	23.6	33	24.2	32.3	4	121	50.9	M4x15	6	2.7	75
SAPL-AS-17 x 31	12.5	17.6	20.1	24.1	33.5	25.4	46.1	5.4	144	63.1	M4x15	8	2.7	75
SAPL-AS-18 x 32	12.5	17.6	20.1	24.1	34.5	26.4	49	5.4	136	61.2	M4x15	8	2.7	80
SAPL-AS-19 x 33	12.5	17.6	20.1	24.1	35.5	27.4	51.9	5.4	129	59.2	M4x15	8	2.7	81
SAPL-AS-20 x 38	15.3	21.1	24.1	29.1	42	30.8	121.6	12.2	165	69.8	M5x18	8	5.6	144
SAPL-AS-22 x 40	15.3	21.1	24.1	29.1	44	32.8	133.4	12.1	150	66.3	M5x18	8	5.6	165
SAPL-AS-24 x 42	16.3	22.1	25.1	30.1	46	34.8	146.1	12.2	128	59.2	M5x18	8	5.6	180
SAPL-AS-25 x 43	17.3	23.1	26.1	31.1	47	35.8	153	12.2	122	54.5	M5x18	8	5.6	188
SAPL-AS-28 x 46	17.3	23.1	26.6	31.6	50	38.8	213.8	15.2	136	63.7	M5x18	10	5.6	195
SAPL-AS-30 x 48	17.3	23.1	26.6	31.6	52	40.8	229.5	15.3	127	61.1	M5x18	10	5.6	208
SAPL-AS-32 x 50	18.3	24.1	27.6	32.6	54	42.8	244.2	15.2	110	55.4	M5x18	10	5.6	219
SAPL-AS-35 x 57	19.5	26	30	36	62	48.4	301.1	17.2	107	51.4	M6x20	8	9.6	325
SAPL-AS-38 x 60	20	26.5	30.5	36.5	65	51.4	403	21.5	119	59.5	M6x20	10	9.6	362
SAPL-AS-40 x 62	20.5	27	31	37	67	53.4	430.6	21.5	110	56.2	M6x20	10	9.6	380
SAPL-AS-42 x 64	20.5	27	31	37	69	55.4	452.2	21.5	105	54.4	M6X20	10	9.6	405
SAPL-AS-45 x 67	21	27.5	31.5	37.5	72	58.4	484.6	21.5	95	50.8	M6X20	10	9.6	435
SAPL-AS-48 x 70	21	27.5	32	38	75	61.4	620.9	25.8	107	58.4	M6X20	12	9.6	460
SAPL-AS-50 x 72	21.5	28	32.5	38.5	77	63.4	754.3	30.1	116	64.6	M6X20	14	9.6	485

- Pt(Max. Permissible Thrust Load) indicates values at the zero(0) torque, and Tc(Max. Permissible Torque) at the zero(0) thrust load respectively. In case torque and thrust load occur simultaneously, please refer to the formula in the [Selection guide] page for combined load calculation.
- For the best performance, make sure all foreign substances e.g. corrosion, dust etc. are removed from each surface of shaft, hub, and A.P. Lock's inner and outer ring.

# A.P. LOCK : SAPL-B SERIES

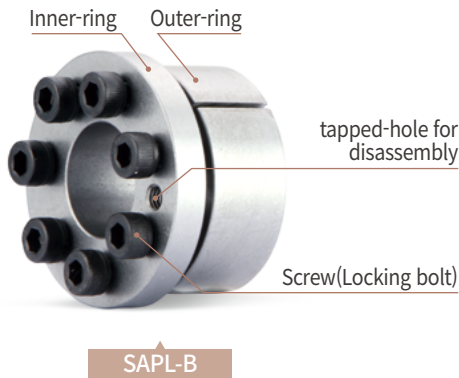

## Structure and Material for SAPL-B Series

Model	Body (Inner-ring / Outer-ring)		Screw(Locking bolt)	
	Material	Surface Treatment	Material	Surface Treatment
SAPL-B	STEEL	-	SCM435	Black Oxide

※ Please contact Sung-il Customer Service team for eletroless nickel plating surface treatment option for SAPL-B Series.

## Product Features

- Self-centering function (prevention of slight off-center matters)
- Higher durability with bigger outer diameters and screws comparing to the same inner diameter products in SAPL-A Series

## Principles

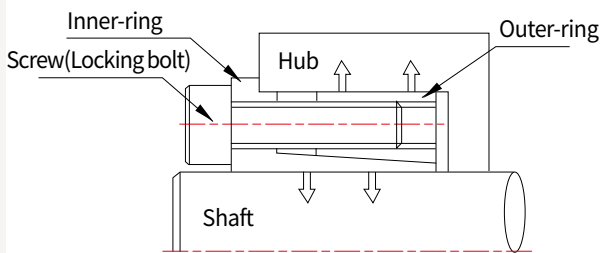

## How to Order

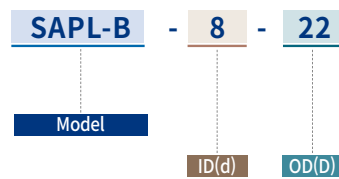

# SAPL-B SERIES : SAPL-B



## Dimensions / Performance

Model d x D	Size ( $\pm 0.3\text{mm}$ )						Max. Permissible Torque (Tc) (N·m)	Max. Permissible Thrust Load (Pt) (kN)	Surface Pressure (MPa)		Screw(Locking bolt)			Mass(g)
	L <sub>1</sub>	L <sub>2</sub>	L <sub>3</sub>	L	D <sub>1</sub>	P.C.D			Shaft(Pi)	Hub(Po)	Size	The no. of screws	Fastening Torque (N·m)	
SAPL-B-8 x 22	10	13	17	21	25	17	18	5	274	70	M4 x 15	3	4	45
SAPL-B-9 x 23	10	13	17	21	26	18	21	5	243	67	M4 x 15	3	4	50
SAPL-B-10 x 24	10	13	17	21	27	19	29	6	294	85	M4 x 15	4	4	53
SAPL-B-11 x 25	10	13	17	21	28	20	33	6	265	82	M4 x 15	4	4	56
SAPL-B-12 x 26	10	13	17	21	29	21	46	8	304	98	M4 x 15	5	4	60
SAPL-B-13 x 27	10	13	17	21	30	22	49	7	280	95	M4 x 15	5	4	63
SAPL-B-14 x 31	12.5	16	21	26	34	25	69	10	261	85	M5 x 15	4	8	100
SAPL-B-15 x 32	12.5	16	21	26	35	25	74	10	243	82	M5 x 15	4	8	105
SAPL-B-16 x 33	12.5	16	21	26	36	26	78	10	228	79	M5 x 15	4	8	110
SAPL-B-17 x 34	12.5	16	21	26	37	27	103	12	268	97	M5 x 15	5	8	115
SAPL-B-18 x 35	12.5	16	21	26	38	28	108	12	253	94	M5 x 15	5	8	120
SAPL-B-19 x 47	20	24	32	38	53	33	284	29	284	92	M6 x 22	6	16	355
SAPL-B-20 x 47	20	24	32	38	53	33	294	29	270	92	M6 x 22	6	16	350
SAPL-B-22 x 47	20	24	32	38	53	37	324	29	245	92	M6 x 22	6	16	335
SAPL-B-24 x 50	20	24	32	38	56	40	412	34	262	101	M6 x 22	7	16	380
SAPL-B-25 x 50	20	24	32	38	56	40	431	34	252	101	M6 x 22	7	16	370
SAPL-B-28 x 55	20	24	32	38	62	45	471	34	225	92	M6 x 22	7	16	440
SAPL-B-30 x 55	20	24	32	38	62	45	510	34	210	92	M6 x 22	7	16	425

- Pt(Max. Permissible Thrust Load) indicates values at the zero(0) torque, and Tc(Max. Permissible Torque) at the zero(0) thrust load respectively. In case torque and thrust load occur simultaneously, please refer to the formula in the [Selection guide] page for combined load calculation.
- For the best performance, make sure all foreign substances e.g. corrosion, dust etc. are removed from each surface of shaft, hub, and A.P. Lock's inner and outer ring.

# A.P. LOCK : SAPL-C SERIES

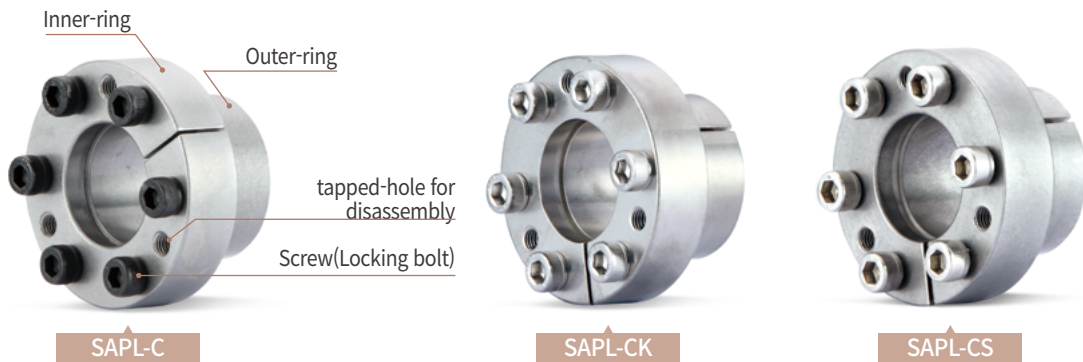

## Structure and Material for SAPL-C Series

Model	Body (Inner-ring / Outer-ring)		Screw(Locking bolt)	
	Material	Surface Treatment	Material	Surface Treatment
SAPL-C	STEEL	-	SCM435	Black Oxide
SAPL-CK	STEEL	Electroless Nickel Plating	SCM435	Electroless Nickel Plating
SAPL-CS	STS304	-	STS304	-

## Product Features

- Self-centering function (prevention of slight off-center matters)
- Designed to suit smaller and shorter hubs (as there is only small difference in dimension between inner(d) and outer(D) diameters, as well as its surface pressure is low) – The most compact-designed series
- No movement while installed as the inner-ring is directly attached to hub surface
- Diverse material & finish options available (e.g. stainless steel body for vacuum area, electroless nickel plating etc.)

## Principles

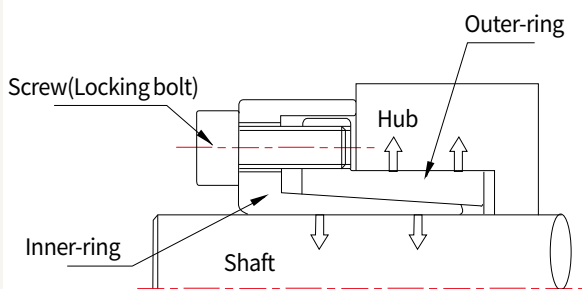

## How to Order

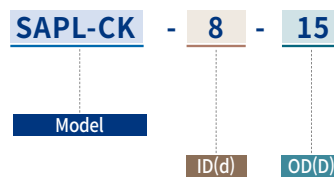

# SAPL-C SERIES : SAPL-C

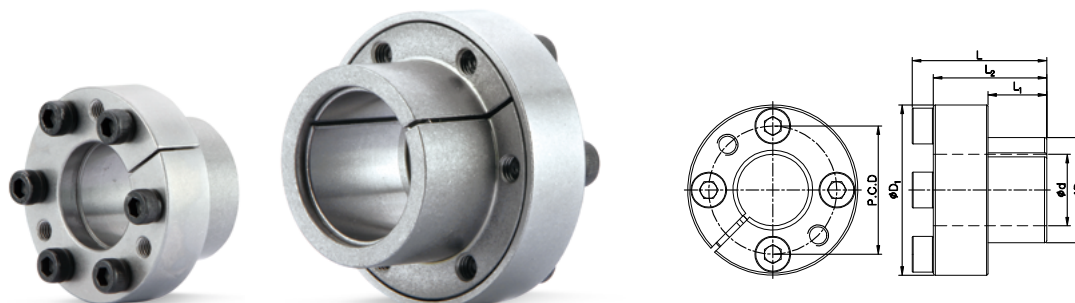

## Dimensions / Performance

Model d x D	Size (±0.3mm)					Max. Permissible Torque (Tc) (N·m)	Max. Permissible Thrust Load (Pt) (kN)	Surface Pressure (MPa)		Screw/Locking bolt			Mass(g)
	L <sub>1</sub>	L <sub>2</sub>	L	D <sub>1</sub>	P.C.D			Shaft(Pi)	Hub(Po)	Size	The no. of screws	Fastening Torque (N·m)	
SAPL-C-5 x 12	10	19	22	23	15.5	9	3.45	188	99	M3x8	4	1.7	36
SAPL-C-6 x 12	10	19	22	23	15.5	11	3.45	156	99	M3x8	4	1.7	34
SAPL-C-8 x 15	12	23	27	28	19.5	25	6.09	174	116	M4x10	4	4	61
SAPL-C-10 x 18	12	23	27	31.5	22.5	44	8.71	193	134	M4x10	5	4	78
SAPL-C-11 x 18	12	23	27	31.5	22.5	48	8.71	176	134	M4x10	5	4	75
SAPL-C-12 x 20	12	23	27	33.5	24.5	53	8.71	161	121	M4x10	5	4	86
SAPL-C-14 x 22	12	23	27	35.5	26.5	61	8.71	138	110	M4x10	5	4	94
SAPL-C-15 x 23	14	27	32	38.5	28.5	115	15.3	178	150	M5x12	4	8	135
SAPL-C-16 x 24	14	27	32	39.5	29.5	123	15.3	167	144	M5x12	4	8	140
SAPL-C-17 x 25	14	27	32	40.5	30.5	131	15.3	158	138	M5x12	4	8	146
SAPL-C-18 x 26	14	30	36	46	33	210	23.2	195	198	M6x14	4	14	221
SAPL-C-19 x 27	14	30	36	47	34	221	23.2	185	191	M6x14	4	14	228
SAPL-C-20 x 28	14	30	36	48	35	233	23.2	176	184	M6x14	4	14	235
SAPL-C-22 x 32	16	32	38	52	39	256	23.2	146	141	M6x14	4	14	287
SAPL-C-24 x 34	16	32	38	54	41	279	23.2	134	133	M6x14	4	14	302
SAPL-C-25 x 34	16	32	38	54	41	291	23.2	128	133	M6x14	4	14	293
SAPL-C-28 x 39	20	36	42	59	46	488	34.8	146	139	M6x14	6	14	378
SAPL-C-30 x 41	20	36	42	61	48	523	34.8	136	132	M6x14	6	14	396

- Pt(Max. Permissible Thrust Load) indicates values at the zero(0) torque, and Tc(Max. Permissible Torque) at the zero(0) thrust load respectively. In case torque and thrust load occur simultaneously, please refer to the formula in the [Selection guide] page for combined load calculation.
- For the best performance, make sure all foreign substances e.g. corrosion, dust etc. are removed from each surface of shaft, hub, and A.P. Lock's inner and outer ring.

# SAPL-C SERIES : SAPL-CK

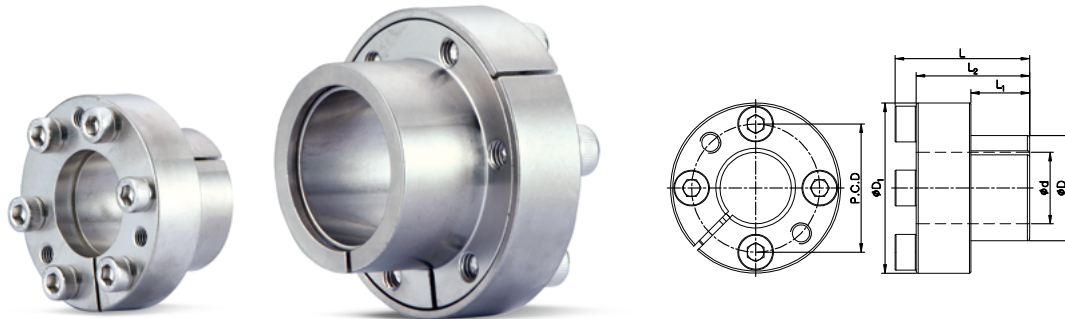

## Dimensions / Performance

Model d x D	Size ( $\pm 0.3\text{mm}$ )					Max. Permissible Torque(Tc) (N·m)	Max. Permissible Thrust Load(Pt) (kN)	Surface Pressure (MPa)		Screw(Locking bolt)			Mass(g)
	L <sub>1</sub>	L <sub>2</sub>	L	D <sub>1</sub>	P.C.D			Shaft(Pi)	Hub(Po)	Size	The no. of screws	Fastening Torque(N·m)	
SAPL-CK-5 x 12	10	19	22	23	15.5	9	3.4	188	99	M3x8	4	1.7	36
SAPL-CK-6 x 12	10	19	22	23	15.5	11	3.4	156	99	M3x8	4	1.7	34
SAPL-CK-8 x 15	12	23	27	28	19.5	25	6	174	116	M4x10	4	4	61
SAPL-CK-10 x 18	12	23	27	31.5	22.5	44	8.7	193	134	M4x10	5	4	78
SAPL-CK-11 x 18	12	23	27	31.5	22.5	48	8.7	176	134	M4x10	5	4	75
SAPL-CK-12 x 20	12	23	27	33.5	24.5	53	8.7	161	121	M4x10	5	4	86
SAPL-CK-14 x 22	12	23	27	35.5	26.5	61	8.7	138	110	M4x10	5	4	94
SAPL-CK-15 x 23	14	27	32	38.5	28.5	115	15.3	178	150	M5x12	4	8	135
SAPL-CK-16 x 24	14	27	32	39.5	29.5	123	15.3	167	144	M5x12	4	8	140
SAPL-CK-17 x 25	14	27	32	40.5	30.5	131	15.3	158	138	M5x12	4	8	146
SAPL-CK-18 x 26	14	30	36	46	33	210	23.2	195	198	M6x14	4	14	221
SAPL-CK-19 x 27	14	30	36	47	34	221	23.2	185	191	M6x14	4	14	228
SAPL-CK-20 x 28	14	30	36	48	35	233	23.2	176	184	M6x14	4	14	235
SAPL-CK-22 x 32	16	32	38	52	39	256	23.2	146	141	M6x14	4	14	287
SAPL-CK-24 x 34	16	32	38	54	41	279	23.2	134	133	M6x14	4	14	302
SAPL-CK-25 x 34	16	32	38	54	41	291	23.2	128	133	M6x14	4	14	293
SAPL-CK-28 x 39	20	36	42	59	46	488	34.8	146	139	M6x14	6	14	378
SAPL-CK-30 x 41	20	36	42	61	48	523	34.8	136	132	M6x14	6	14	396

- Pt(Max. Permissible Thrust Load) indicates values at the zero(0) torque, and Tc(Max. Permissible Torque) at the zero(0) thrust load respectively. In case torque and thrust load occur simultaneously, please refer to the formula in the [Selection guide] page for combined load calculation.
- For the best performance, make sure all foreign substances e.g. corrosion, dust etc. are removed from each surface of shaft, hub, and A.P. Lock's inner and outer ring.

# SAPL-C SERIES : SAPL-CS

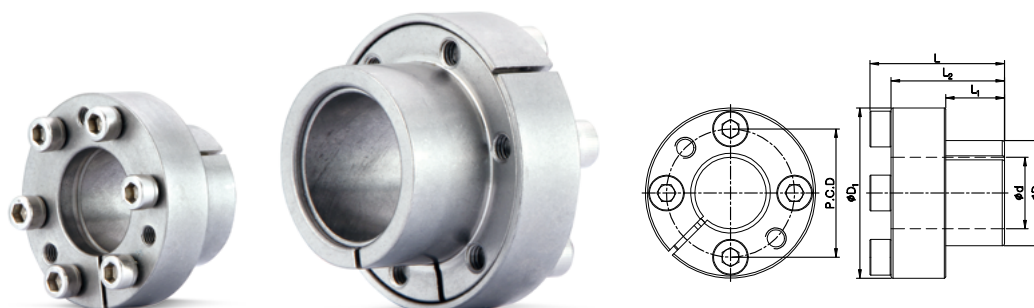

## Dimensions / Performance

Model d x D	Size ( $\pm 0.3\text{mm}$ )					Max. Permissible Torque(Tc) (N·m)	Max. Permissible Thrust Load(Pt) (kN)	Surface Pressure (MPa)		Screw(Locking bolt)			Mass(g)
	L <sub>1</sub>	L <sub>2</sub>	L	D <sub>1</sub>	P.C.D			Shaft(Pi)	Hub(Po)	Size	The no. of screws	Fastening Torque(N·m)	
SAPL-CS-5 x 12	10	19	22	23	15.5	3	1.1	57	30	M3x8	4	1.1	36
SAPL-CS-6 x 12	10	19	22	23	15.5	4	1.1	48	30	M3x8	4	1.1	34
SAPL-CS-8 x 15	12	23	27	28	19.5	8	1.9	55	37	M4x10	4	2.7	61
SAPL-CS-10 x 18	12	23	27	31.5	22.5	14	2.7	61	43	M4x10	5	2.7	78
SAPL-CS-11 x 18	12	23	27	31.5	22.5	16	2.7	56	43	M4x10	5	2.7	75
SAPL-CS-12 x 20	12	23	27	33.5	24.5	17	2.7	51	39	M4x10	5	2.7	86
SAPL-CS-14 x 22	12	23	27	35.5	26.5	20	2.7	44	35	M4x10	5	2.7	94
SAPL-CS-15 x 23	14	27	32	38.5	28.5	38	5	59	49	M5x12	4	5.6	135
SAPL-CS-16 x 24	14	27	32	39.5	29.5	41	5	55	47	M5x12	4	5.6	140
SAPL-CS-17 x 25	14	27	32	40.5	30.5	43	5	52	46	M5x12	4	5.6	146
SAPL-CS-18 x 26	14	30	36	46	33	68	7.4	63	64	M6x14	4	9.6	221
SAPL-CS-19 x 27	14	30	36	47	34	71	7.4	60	62	M6x14	4	9.6	228
SAPL-CS-20 x 28	14	30	36	48	35	75	7.4	57	59	M6x14	4	9.6	235
SAPL-CS-22 x 32	16	32	38	52	39	83	7.4	47	46	M6x14	4	9.6	287
SAPL-CS-24 x 34	16	32	38	54	41	90	7.4	43	43	M6x14	4	9.6	302
SAPL-CS-25 x 34	16	32	38	54	41	94	7.4	42	43	M6x14	4	9.6	293
SAPL-CS-28 x 39	20	36	42	59	46	157	11.1	47	45	M6x14	6	9.6	378
SAPL-CS-30 x 41	20	36	42	61	48	168	11.1	44	43	M6x14	6	9.6	396

- Pt(Max. Permissible Thrust Load) indicates values at the zero(0) torque, and Tc(Max. Permissible Torque) at the zero(0) thrust load respectively. In case torque and thrust load occur simultaneously, please refer to the formula in the [Selection guide] page for combined load calculation.
- For the best performance, make sure all foreign substances e.g. corrosion, dust etc. are removed from each surface of shaft, hub, and A.P. Lock's inner and outer ring.

# A.P. LOCK : SAPL-D1

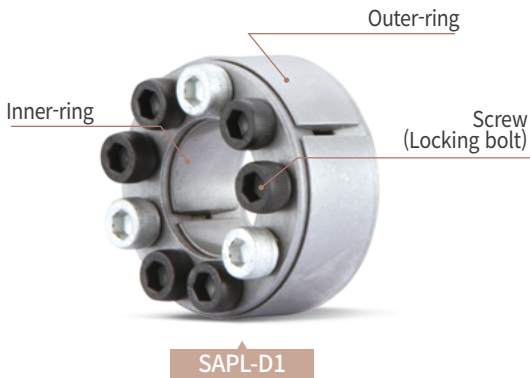

## Structure and Material for SAPL-D1 Series

Model	Body (Inner-ring / Outer-ring)		Screw(Locking bolt)	
	Material	Surface Treatment	Material	Surface Treatment
SAPL-D1	STEEL	-	SCM435	Black Oxide

※ Please contact Sung-il Customer Service team for eletroless nickel plating surface treatment option for SAPL-D1 Series.

## Product Features

- The most standard clamping structure between shaft and hub
- Relatively higher clamping force
- A wide range of standard inner diameters (from Ø18 to Ø200)
- Recommended tolerance (Shaft's OD: h8, Hub's ID: H8)
- Simple structure for easier installation & handier maintenance

## Principles

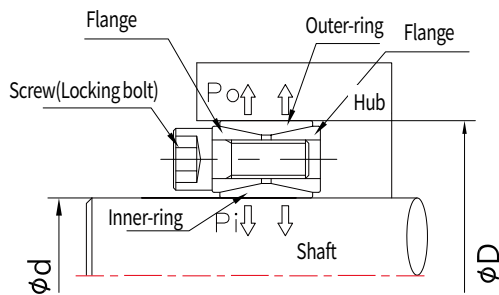

- ※ If more than 2pcs of SAPL-D1 are mounted simultaneously, the clamping force on shaft (permissible torque) becomes higher.
- SAPL-D1/ 1pc mounted:  $T_c$  (Max. Permissible Torque)
  - SAPL-D1/ 2pcs mounted :  $T_c$  (Max. Permissible Torque) x 1.9
  - SAPL-D1/ 3pcs mounted :  $T_c$  (Max. Permissible Torque) x 2.7

## How to Order

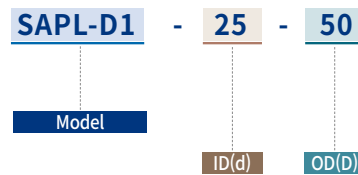

# SAPL-D SERIES : SAPL-D1

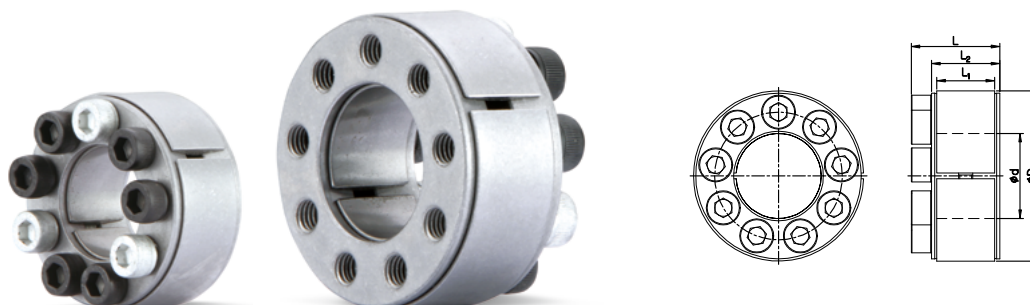

## Dimensions / Performance

Model d x D	Size (±0.3mm)			Max. Permissible Torque(Tc) (N·m)	Max. Permissible Thrust Load(Pt) (kN)	Surface Pressure (MPa)		Screw(Locking bolt)			Mass(g)
	L <sub>1</sub>	L <sub>2</sub>	L			Shaft(Pi)	Hub(Po)	Size	The no. of screws	Fastening Torque(N·m)	
SAPL-D1-18 x 47	17	20	26	240	26.5	210	85	M6x18	8	14.9	200
SAPL-D1-19 x 47	17	20	26	245	26.5	210	85	M6x18	8	14.9	200
SAPL-D1-20 x 47	17	20	26	265	26.5	199	85	M6x18	8	14.9	200
SAPL-D1-22 x 47	17	20	26	294	26.5	181	85	M6x18	8	14.9	190
SAPL-D1-24 x 50	17	20	26	402	33.3	211	101	M6x18	9	14.9	220
SAPL-D1-25 x 50	17	20	26	421	33.3	203	101	M6x18	9	14.9	220
SAPL-D1-28 x 55	17	20	26	470	33.3	180	92	M6x18	10	14.9	220
SAPL-D1-30 x 55	17	20	26	510	33.3	169	92	M6x18	10	14.9	240
SAPL-D1-32 x 60	17	20	26	676	42.1	198	106	M6x18	12	14.9	270
SAPL-D1-35 x 60	17	20	26	745	42.1	181	106	M6x18	12	14.9	270
SAPL-D1-38 x 65	17	20	26	892	47	183	107	M6x18	14	14.9	300
SAPL-D1-40 x 65	17	20	26	941	47	174	107	M6x18	14	14.9	300
SAPL-D1-42 x 75	20	24	32	1,490	70.6	214	121	M8x22	12	35	510
SAPL-D1-45 x 75	20	24	32	1,600	70.6	200	121	M8x22	12	35	510
SAPL-D1-48 x 80	20	24	32	1,700	70.6	188	113	M8x22	12	35	550
SAPL-D1-50 x 80	20	24	32	1,770	70.6	180	113	M8x22	12	35	550
SAPL-D1-55 x 85	20	24	32	2,390	86.2	201	130	M8x22	14	35	600
SAPL-D1-60 x 90	20	24	32	2,610	86.2	184	123	M8x22	14	35	640
SAPL-D1-65 x 95	20	24	32	3,228	99	225	154	M8x22	16	35	700
SAPL-D1-70 x 110	24	28	38	4,811	138	241	154	M10x25	14	69	1,240
SAPL-D1-75 x 115	24	28	38	5,154	138	225	147	M10x25	14	69	1,290
SAPL-D1-80 x 120	24	28	38	5,497	138	212	140	M10x25	14	69	1,350
SAPL-D1-85 x 125	24	28	38	6,675	158	227	155	M10x25	16	69	1,430
SAPL-D1-90 x 130	24	28	38	7,069	158	214	149	M10x25	16	69	1,500
SAPL-D1-95 x 135	24	28	38	8,393	176	229	161	M10x25	18	69	1,540
SAPL-D1-100 x 145	26	33	45	10,226	204	232	160	M12x30	14	69	2,200
SAPL-D1-110 x 155	26	33	45	11,248	204	211	149	M12x30	14	123.3	2,300
SAPL-D1-120 x 165	26	33	45	14,020	234	221	160	M12x30	16	123.3	2,400
SAPL-D1-130 x 180	34	38	50	18,986	293	195	140	M12x35	20	123.3	3,600
SAPL-D1-140 x 190	34	38	50	22,494	321	199	147	M12x35	22	123.3	3,900
SAPL-D1-150 x 200	34	38	50	26,295	351	203	152	M12x35	24	123.3	4,000
SAPL-D1-160 x 210	34	38	50	33,756	422	229	174	M12x35	26	123.3	4,300
SAPL-D1-170 x 225	38	44	58	39,483	465	212	160	M14x40	22	187	5,700
SAPL-D1-180 x 235	38	44	58	45,606	507	218	167	M14x40	24	187	6,000
SAPL-D1-190 x 250	46	52	66	56,163	591	199	152	M14x45	28	187	8,200
SAPL-D1-200 x 260	46	52	66	63,342	633	203	156	M14x45	30	187	8,600

- Pt(Max. Permissible Thrust Load) indicates values at the zero(0) torque, and Tc(Max. Permissible Torque) at the zero(0) thrust load respectively. In case torque and thrust load occur simultaneously, please refer to the formula in the [Selection guide] page for combined load calculation.
- For the best performance, make sure all foreign substances e.g. corrosion, dust etc. are removed from each surface of shaft, hub, and A.P. Lock's inner and outer ring.

# A.P. LOCK : SAPL-D2

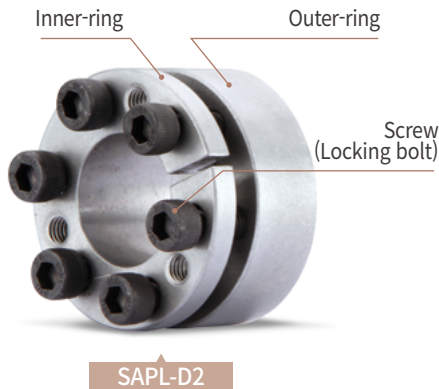

## Structure and Material for SAPL-D2 Series

Model	Body (Inner-ring / Outer-ring)		Screw(Locking bolt)	
	Material	Surface Treatment	Material	Surface Treatment
SAPL-D2	STEEL	-	SCM435	Black Oxide

※ Please contact Sung-il Customer Service team for eletroless nickel plating surface treatment option for SAPL-D2 Series.

## Product Features

- Equivalent to SAPL-D1 series with the same dimensions (which is the most standard clamping structure between shaft and hub)
- Effective installation with less quantity of fastening screws
- Axial movement of the shaft may occur while installed
- Self-centering function (prevention of slight off-center matters)
- Recommended tolerance (Shaft's OD: h8, Hub's ID: H8)

## Principles

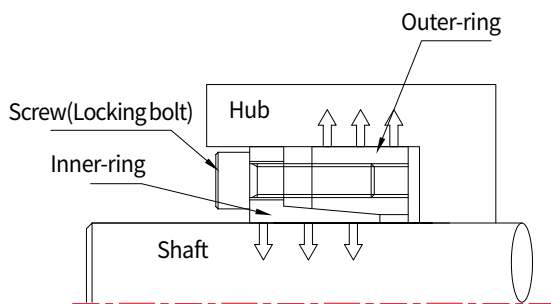

## How to Order

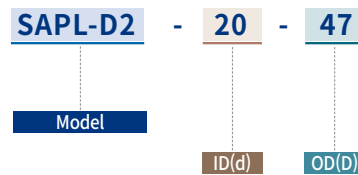

# SAPL-D SERIES : SAPL-D2

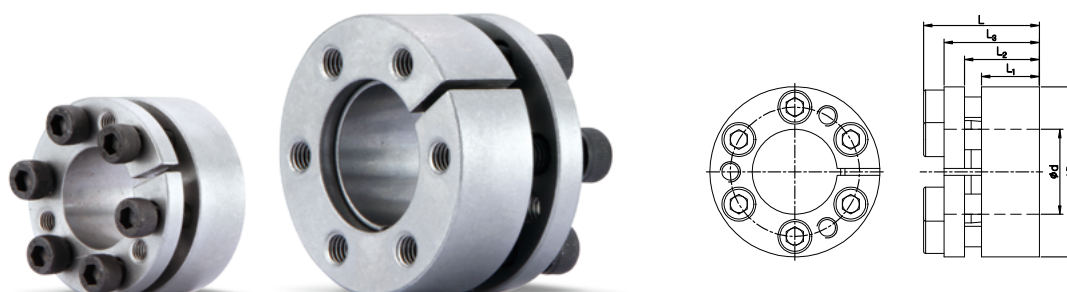

## Dimensions / Performance

Model d x D	Size ( $\pm 0.3\text{mm}$ )				Max. Permissible Torque(Tc) (N·m)	Max. Permissible Thrust Load(Pt) (kN)	Surface Pressure (MPa)		Screw(Locking bolt)			Mass(g)
	L <sub>1</sub>	L <sub>2</sub>	L <sub>3</sub>	L			Shaft(Pi)	Hub(Po)	Size	The no. of screws	Fastening Torque(N·m)	
SAPL-D2-19 x 47	17	22	28	34	273	29	262	106	M6x20	5	13	300
SAPL-D2-20 x 47	17	22	28	34	287	29	249	106	M6x20	5	13	300
SAPL-D2-22 x 47	17	22	28	34	316	29	227	106	M6x20	5	13	300
SAPL-D2-24 x 50	17	22	28	34	413	34	249	120	M6x20	6	13	300
SAPL-D2-25 x 50	17	22	28	34	431	34	239	120	M6x20	6	13	300
SAPL-D2-28 x 55	17	22	28	34	482	34	213	109	M6x20	6	13	400
SAPL-D2-30 x 55	17	22	28	34	517	34	199	109	M6x20	6	13	400
SAPL-D2-32 x 60	17	22	28	34	734	46	249	133	M6x20	8	13	400
SAPL-D2-35 x 60	17	22	28	34	803	46	227	133	M6x20	8	13	400
SAPL-D2-38 x 65	17	22	28	34	872	46	210	122	M6x20	8	13	400
SAPL-D2-40 x 65	17	22	28	34	918	46	199	122	M6x20	8	13	400
SAPL-D2-42 x 75	17	25	33	41	1,573	74	261	146	M8x25	7	32	800
SAPL-D2-45 x 75	20	25	33	41	1,674	74	244	146	M8x25	7	32	800
SAPL-D2-48 x 80	20	25	33	41	1,750	74	220	146	M8x25	7	32	800
SAPL-D2-50 x 80	20	25	33	41	1,860	74	219	137	M8x25	7	32	800
SAPL-D2-55 x 85	20	25	33	41	2,340	85	228	148	M8x25	8	32	800
SAPL-D2-60 x 90	20	25	33	41	2,553	85	209	139	M8x25	8	32	800

- Pt(Max. Permissible Thrust Load) indicates values at the zero(0) torque, and Tc(Max. Permissible Torque) at the zero(0) thrust load respectively. In case torque and thrust load occur simultaneously, please refer to the formula in the [Selection guide] page for combined load calculation.
- For the best performance, make sure all foreign substances e.g. corrosion, dust etc. are removed from each surface of shaft, hub, and A.P. Lock's inner and outer ring.

# A.P. LOCK : SAPL-D3

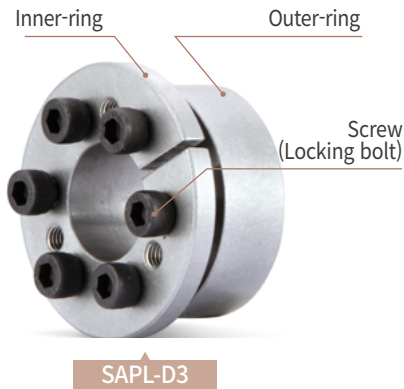

## Structure and Material for SAPL-D3 Series

Model	Body (Inner-ring / Outer-ring)		Screw(Locking bolt)	
	Material	Surface Treatment	Material	Surface Treatment
SAPL-D3	STEEL	-	SCM435	Black Oxide

※ Please contact Sung-il Customer Service team for eletroless nickel plating surface treatment option for SAPL-D3 Series.

## Product Features

- Equivalent to SAPL-D1 series with the same dimensions (which is the most standard clamping structure between shaft and hub)
- Effective installation with less quantity of fastening screws
- No movement while installed as the flange-shaped part is directly attached to hub surface
- Self-centering function (prevention of slight off-center matters)
- Recommended tolerance (Shaft's OD: h8, Hub's ID: H8)

## Principles

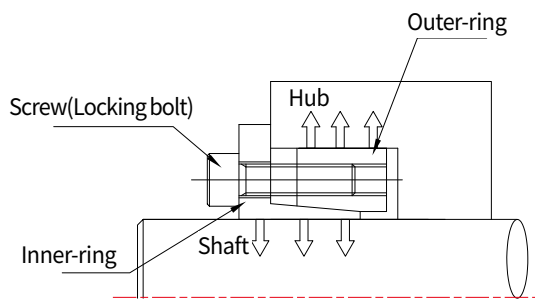

## How to Order

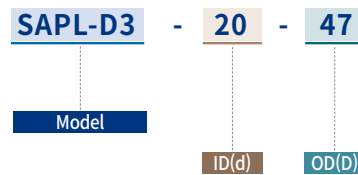

# SAPL-D SERIES : SAPL-D3

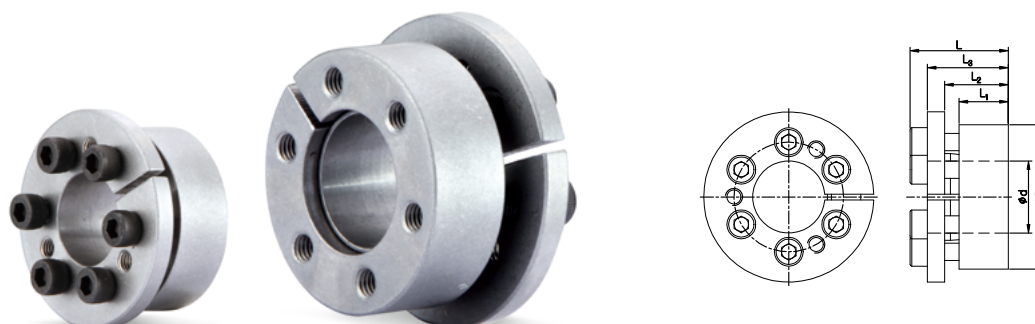

## Dimensions / Performance

Model d x D	Size (±0.3mm)					Max. Permissible Torque(Tc) (N·m)	Max. Permissible Thrust Load(Pt) (kN)	Surface Pressure (MPa)		Screw(Locking bolt)			Mass(g)
	D <sub>1</sub>	L <sub>1</sub>	L <sub>2</sub>	L <sub>3</sub>	L			Shaft(Pi)	Hub(Po)	Size	The no. of screws	Fastening Torque(N·m)	
SAPL-D3-19 x 47	56	17	22	28	34	243	26	234	94	M6x20	5	17	300
SAPL-D3-20 x 47	56	17	22	28	34	256	26	222	94	M6x20	5	17	300
SAPL-D3-22 x 47	56	17	22	28	34	282	26	202	94	M6x20	5	17	300
SAPL-D3-24 x 50	59	17	22	28	34	368	31	222	106	M6x20	6	17	300
SAPL-D3-25 x 50	59	17	22	28	34	383	31	213	106	M6x20	6	17	300
SAPL-D3-28 x 55	64	17	22	28	34	429	31	190	97	M6x20	6	17	400
SAPL-D3-30 x 55	64	17	22	28	34	460	31	177	97	M6x20	6	17	400
SAPL-D3-32 x 60	69	17	22	28	34	655	41	222	118	M6x20	8	17	400
SAPL-D3-35 x 60	69	17	22	28	34	716	41	203	118	M6x20	8	17	400
SAPL-D3-38 x 65	74	17	22	28	34	778	41	187	109	M6x20	8	17	500
SAPL-D3-40 x 65	74	17	22	28	34	819	41	178	109	M6x20	8	17	500
SAPL-D3-42 x 75	84	17	25	33	41	1,361	65	227	127	M8x25	7	41	800
SAPL-D3-45 x 75	84	20	25	33	41	1,458	65	212	127	M8x25	7	41	700
SAPL-D3-48 x 80	89	20	25	33	41	1,550	65	200	123	M8x25	7	41	800
SAPL-D3-50 x 80	89	20	25	33	41	1,620	65	191	119	M8x25	7	41	800
SAPL-D3-55 x 85	94	20	25	33	41	2,037	74	199	129	M8x25	8	41	900
SAPL-D3-60 x 90	99	20	25	33	41	2,223	74	182	121	M8x25	8	41	900

- Pt(Max. Permissible Thrust Load) indicates values at the zero(0) torque, and Tc(Max. Permissible Torque) at the zero(0) thrust load respectively. In case torque and thrust load occur simultaneously, please refer to the formula in the [Selection guide] page for combined load calculation.
- For the best performance, make sure all foreign substances e.g. corrosion, dust etc. are removed from each surface of shaft, hub, and A.P. Lock's inner and outer ring.

# A.P. LOCK : SAPL-D4

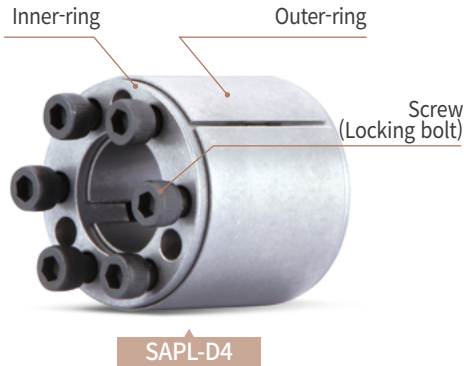

## Structure and Material for SAPL-D4 Series

Model	Body (Inner-ring / Outer-ring)		Screw(Locking bolt)	
	Material	Surface Treatment	Material	Surface Treatment
SAPL-D4	STEEL	-	SCM435	Black Oxide

※ Please contact Sung-il Customer Service team for eletroless nickel plating surface treatment option for SAPL-D4 Series.

## Product Features

- Excellent for high-torque transmission capacity
- Equivalent to SAPL-D1 series with the same dimensions (which is the most standard clamping structure between shaft and hub) in particular to the double-row SAPL-D1 version
- Self-centering function (prevention of slight off-center matters)
- Recommended tolerance (Shaft's OD: h8, Hub's ID: H8)

## Principles

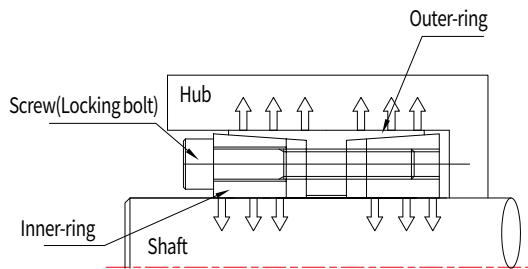

## How to Order

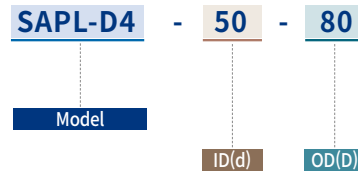

# SAPL-D SERIES : SAPL-D4

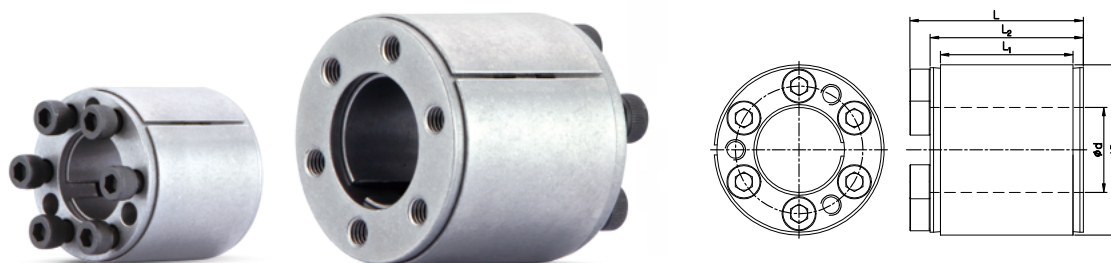

## Dimensions / Performance

Model d x D	Size ( $\pm 0.3\text{mm}$ )			Max. Permissible Torque(Tc) (N·m)	Max. Permissible Thrust Load(Pt) (kN)	Surface Pressure (MPa)		Screw/Locking bolt			Mass(g)
	L <sub>1</sub>	L <sub>2</sub>	L			Shaft(Pi)	Hub(Po)	Size	The no. of screws	Fastening Torque(N·m)	
SAPL-D4-19 x 47	39	45	51	360	40	135	60	M6	6	17	400
SAPL-D4-20 x 47	39	45	51	380	40	140	60	M6	6	17	400
SAPL-D4-22 x 47	39	45	51	425	40	125	60	M6	6	17	400
SAPL-D4-24 x 50	39	45	51	660	53	155	75	M6	6	17	500
SAPL-D4-25 x 50	39	45	51	680	53	150	75	M6	6	17	500
SAPL-D4-28 x 55	39	45	51	750	42	135	65	M6	8	17	600
SAPL-D4-30 x 55	39	45	51	790	53	120	65	M6	8	17	600
SAPL-D4-32 x 60	39	45	51	1,250	80	165	90	M6	8	17	600
SAPL-D4-35 x 60	39	45	51	1,400	80	155	90	M6	8	17	600
SAPL-D4-38 x 65	39	45	51	1,650	90	160	90	M6	10	17	700
SAPL-D4-40 x 65	39	45	51	1,750	90	150	90	M6	10	17	700
SAPL-D4-42 x 75	39	45	53	3,100	155	200	110	M8	8	41	1,000
SAPL-D4S-45 x 75	39	45	53	3,200	155	180	110	M8	8	41	900
SAPL-D4-45 x 75	56	64	72	3,460	155	165	100	M8	8	41	1,300
SAPL-D4-48 x 80	56	64	72	3,680	155	150	95	M8	8	41	1,500
SAPL-D4-50 x 80	56	64	72	3,820	155	147	95	M8	8	41	1,400
SAPL-D4-55 x 85	56	64	72	4,260	155	135	85	M8	8	41	1,500
SAPL-D4-60 x 90	56	64	72	5,820	190	155	100	M8	10	41	1,500
SAPL-D4-65 x 95	56	64	72	6,276	190	190	100	M8	10	41	1,600
SAPL-D4-70 x 110	70	78	88	10,950	310	230	120	M10	10	83	3,000
SAPL-D4-75 x 115	70	78	88	11,700	310	220	110	M10	10	83	3,100
SAPL-D4-80 x 120	70	78	88	13,700	340	220	120	M10	12	83	3,500

- Pt(Max. Permissible Thrust Load) indicates values at the zero(0) torque, and Tc(Max. Permissible Torque) at the zero(0) thrust load respectively. In case torque and thrust load occur simultaneously, please refer to the formula in the [Selection guide] page for combined load calculation.
- For the best performance, make sure all foreign substances e.g. corrosion, dust etc. are removed from each surface of shaft, hub, and A.P. Lock's inner and outer ring.

# A.P. LOCK : SAPL-E SERIES

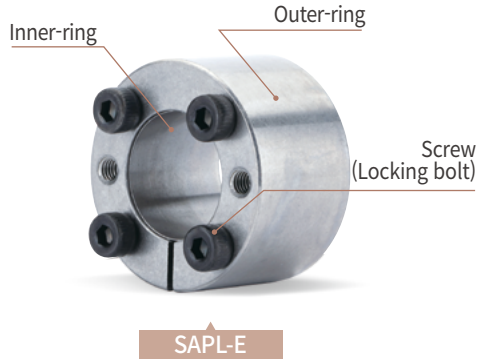

## Structure and Material for SAPL-E Series

Model	Body (Inner-ring / Outer-ring)		Screw(Locking bolt)	
	Material	Surface Treatment	Material	Surface Treatment
SAPL-E	STEEL	-	SCM435	Black Oxide

※ Please contact Sung-il Customer Service team for eletroless nickel plating surface treatment option for SAPL-E Series.

## Product Features

- Self-centering function (prevention of slight off-center matters)
- Designed to suit relatively smaller hubs (as its surface pressure is low)
- One of compact options with a relatively shorter length
- Recommended tolerance (Shaft's OD: h8, Hub's ID: H8)

## Principles

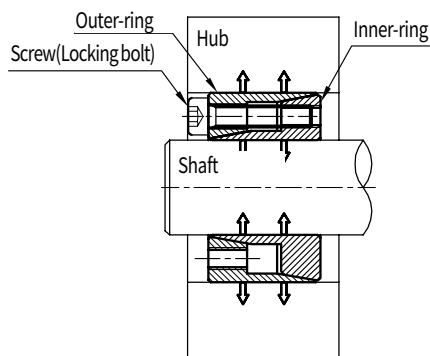

## How to Order

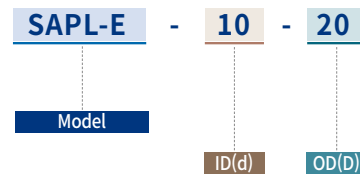

# SAPL-E SERIES : SAPL-E

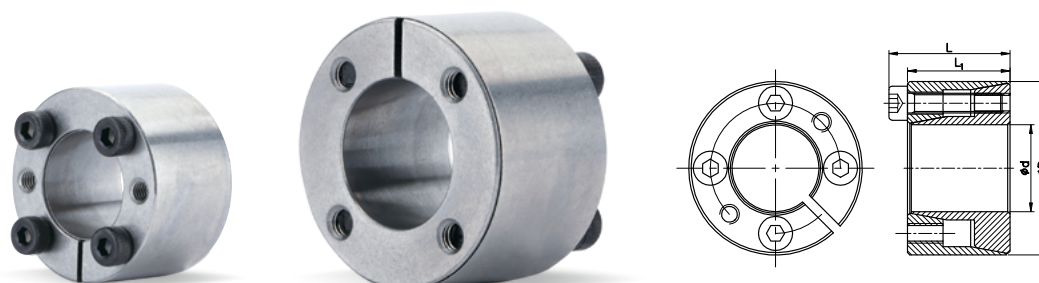

## Dimensions / Performance

Model d x D	Size ( $\pm 0.3\text{mm}$ )		Max. Permissible Torque(Tc) (N·m)	Max. Permissible Thrust Load(Pt) (kN)	Surface Pressure (MPa)		Screw(Locking bolt)			Mass(g)
	L <sub>1</sub>	L			Shaft(Pi)	Hub(Po)	Size	The no. of screws	Fastening Torque(N·m)	
SAPL-E-5 x 16	11	13.5	5	1.6	163	55	M2.5x10	3	1.2	11
SAPL-E-6 x 16	11	13.5	6	2	150	55	M2.5x10	3	1.2	12
SAPL-E-8 x 18	11	13.5	10	2.5	110	45	M2.5x10	3	1.2	15
SAPL-E-9 x 20	13	15.5	15	3	110	45	M2.5x12	4	1.2	20
SAPL-E-10 x 20	13	15.5	19	3.8	89	45	M2.5x12	4	1.2	19
SAPL-E-11 x 22	13	15.5	21	3.8	81	41	M2.5x12	4	1.2	24
SAPL-E-12 x 22	13	15.5	23	3.8	75	41	M2.5x12	4	1.2	22
SAPL-E-14 x 26	17	20	39	5.5	71	38	M3x16	4	2.1	39
SAPL-E-15 x 28	17	20	42	5.5	66	35	M3x16	4	2.1	44
SAPL-E-16 x 32	17	21	77	9.6	107	54	M4x16	4	4.9	68
SAPL-E-17 x 35	21	25	82	9.6	81	40	M4x20	4	4.9	93
SAPL-E-18 x 35	21	25	87	9.6	77	40	M4x20	4	4.9	90
SAPL-E-19 x 35	21	25	91	9.6	73	40	M4x20	4	4.9	85
SAPL-E-20 x 38	21	26	157	15.7	113	60	M5x20	4	10	120
SAPL-E-22 x 40	21	26	173	15.7	103	57	M5x20	4	10	130
SAPL-E-24 x 47	26	32	268	22.3	110	56	M6x24	4	17	220
SAPL-E-25 x 47	26	32	279	22.3	105	56	M6x24	4	17	210
SAPL-E-28 x 50	26	32	468	33.5	141	79	M6x24	6	17	240
SAPL-E-30 x 55	26	32	502	33.5	132	72	M6x24	6	17	270

- Pt(Max. Permissible Thrust Load) indicates values at the zero(0) torque, and Tc(Max. Permissible Torque) at the zero(0) thrust load respectively. In case torque and thrust load occur simultaneously, please refer to the formula in the [Selection guide] page for combined load calculation.
- For the best performance, make sure all foreign substances e.g. corrosion, dust etc. are removed from each surface of shaft, hub, and A.P. Lock's inner and outer ring.

# A.P. LOCK : SAPL-T SERIES

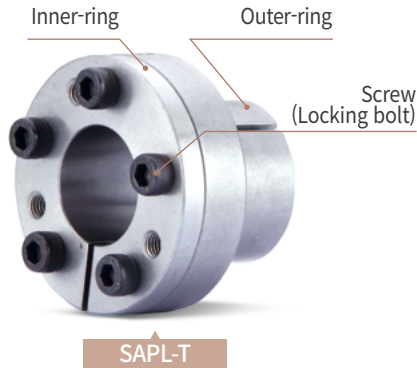

## Structure and Material for SAPL-T Series

Model	Body (Inner-ring / Outer-ring)		Screw(Locking bolt)	
	Material	Surface Treatment	Material	Surface Treatment
SAPL-T	STEEL	-	SCM435	Black Oxide

※ Please contact Sung-il Customer Service team for eletroless nickel plating surface treatment option for SAPL-T Series.

## Product Features

- Designed to suit smaller and shorter hubs
- No movement while installed
- Self-centering function (prevention of slight off-center matters)
- Simple structure for easier installation & handier maintenance
- Recommended tolerance (Shaft's OD: h8, Hub's ID: H8)

## Principles

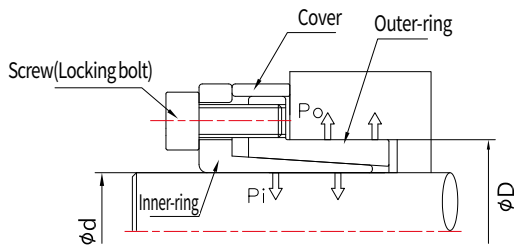

## How to Order

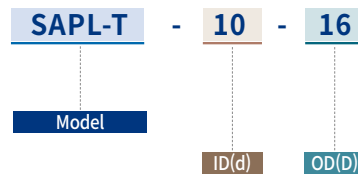

# SAPL-T SERIES : SAPL-T

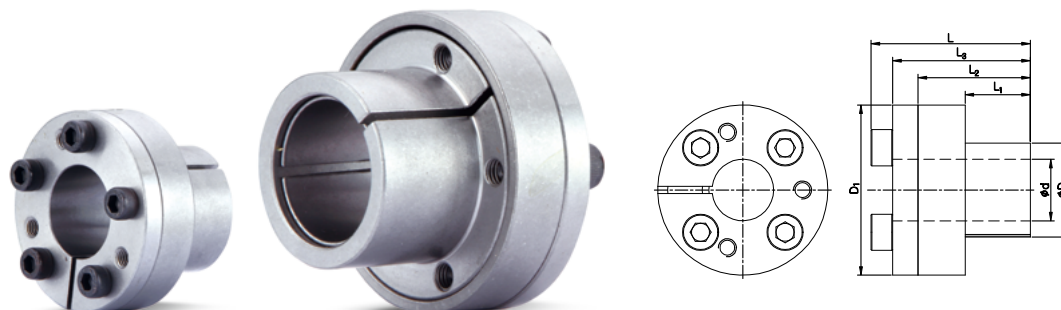

## Dimensions / Performance

Model d x D	Size ( $\pm 0.3\text{mm}$ )					Max. Permissible Torque(Tc) (N·m)	Max. Permissible Thrust Load(Pt) (kN)	Surface Pressure (MPa)		Screw(Locking bolt)			Mass(g)
	L <sub>1</sub>	L <sub>2</sub>	L <sub>3</sub>	L	D <sub>1</sub>			Shaft(Pi)	Hub(Po)	Size	The no. of screws	Fastening Torque(N·m)	
SAPL-T-6 x 14	10	18.5	21	24	25	12	4	185	80	M3x8	3	2	40
SAPL-T-7 x 15	12	21	24	28	27	25	7	235	110	M4x10	3	5	60
SAPL-T-8 x 15	12	21	24	28	28	29	7	205	110	M4x10	4	5	50
SAPL-T-9 x 16	14	23	27	31	32	44	10	205	115	M4x12	4	5	60
SAPL-T-10 x 16	14	23	27	31	32	49	10	185	115	M4x12	4	5	60
SAPL-T-11 x 18	14	23	27	31	34	53	10	170	105	M4x12	4	5	70
SAPL-T-12 x 18	14	23	27	31	34	58	10	160	105	M4x12	4	5	70
SAPL-T-13 x 23	14	23	27	31	39	63	10	140	80	M4x12	4	5	110
SAPL-T-14 x 23	14	23	27	31	39	68	10	130	80	M4x12	4	17	100
SAPL-T-15 x 24	16	29	36	42	45	127	17	185	115	M6x18	3	17	220
SAPL-T-16 x 24	16	29	36	42	45	136	17	175	115	M6x18	3	17	220
SAPL-T-17 x 26	18	31	38	44	47	180	22	190	125	M6x18	4	17	250
SAPL-T-18 x 26	18	31	38	44	47	200	22	180	125	M6x18	4	17	240
SAPL-T-19 x 27	18	31	38	44	48	210	22	170	120	M6x18	4	17	260
SAPL-T-20 x 28	18	31	38	44	49	220	22	160	115	M6x18	4	17	270
SAPL-T-22 x 32	25	38	45	51	54	250	22	115	80	M6x18	4	17	340
SAPL-T-24 x 34	25	38	45	51	56	270	22	105	75	M6x18	4	17	360
SAPL-T-25 x 34	25	38	45	51	56	280	22	100	75	M6x18	4	17	350
SAPL-T-28 x 39	25	38	45	51	61	465	33	135	97	M6x18	5	17	480
SAPL-T-30 x 41	25	38	45	51	63	510	33	127	90	M6x18	6	17	480
SAPL-T-32 x 43	30	43	50	56	65	540	33	120	90	M6x18	6	17	470
SAPL-T-35 x 47	30	43	50	56	69	790	45	105	80	M6x18	8	17	580
SAPL-T-38 x 50	30	43	50	56	72	860	45	100	75	M6x18	8	17	610
SAPL-T-40 x 53	32	45	52	58	75	900	45	95	70	M6x18	9	17	680
SAPL-T-42 x 55	32	45	52	58	77	950	45	90	85	M6x18	9	17	760
SAPL-T-45 x 59	40	56	64	72	85	1,890	84	110	80	M8x22	8	41	1,200
SAPL-T-48 x 62	40	56	64	72	88	2,010	84	105	75	M8x22	8	41	1,200
SAPL-T-50 x 65	50	66	74	82	92	2,100	84	100	65	M8x22	10	41	1,400

- Pt(Max. Permissible Thrust Load) indicates values at the zero(0) torque, and Tc(Max. Permissible Torque) at the zero(0) thrust load respectively. In case torque and thrust load occur simultaneously, please refer to the formula in the [Selection guide] page for combined load calculation.
- For the best performance, make sure all foreign substances e.g. corrosion, dust etc. are removed from each surface of shaft, hub, and A.P. Lock's inner and outer ring.

# A.P. LOCK : SAPL-R SERIES



## Structure and Material for SAPL-R Series

Model	Body (Inner-ring / Outer-ring)	
	Material	Surface Treatment
SAPL-R	STEEL	-

※ Please contact Sung-il Customer Service team for eletroless nickel plating surface treatment option for SAPL-R Series.

## Product Features

- Relatively lower Transmissible torque
- Compact design for limited space of Hub's OD
- Recommended tolerance for Shaft: h6 ( $\leq$  ID 40mm), h8 ( $\geq$  ID 42mm)
- Recommended tolerance for Hub: H7 ( $\leq$  40mm), H8 ( $\geq$  ID 42mm)

## Principles

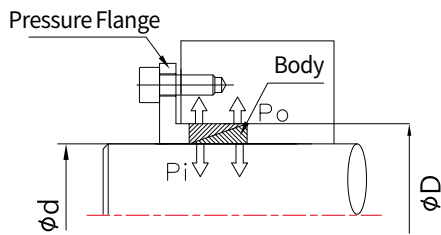

## How to Order

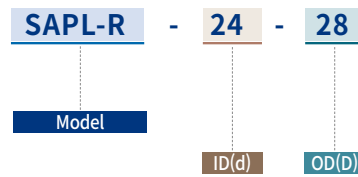

# SAPL-R SERIES : SAPL-R

## Selection and Design Guide

### Design of Pressure Flange

In general, SAPL-R series is supposed to be used along with pressure flanges whose design varies according to user's shaft/hub design. Please refer to the below design variables.

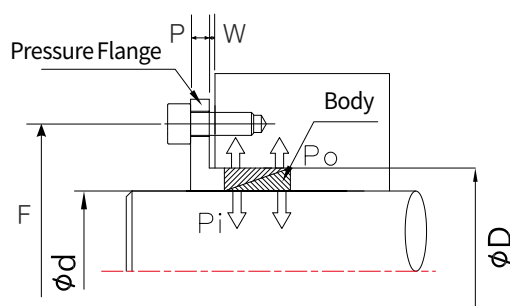

#### 1. Location of screws (locking bolts) on the pressure flange (F)

- 1) Case1: Pressure flange mounted on Hub  
 $F = D + 12 + d_b$  (screw size)
- 2) Case2: Pressure flange mounted on Shaft  
 $F = D - 12 - d_b$  (screw size)

#### 2. Thickness of pressure flange (P)

- 1) Case1: Fastened with Grade 8.8 class screw  
 $P = 1.3 \times d_b$  (screw size)
- 2) Case2: Fastened with Grade 12.9 class screw  
 $P = 1.8 \times d_b$  (screw size)

※ If more than 2pcs of SAPL-R are mounted simultaneously  
 - Distance(W) between pressure flange and hub/shaft has to be adjusted. Please refer to "Dimensions / Performance" pages for (W) values.

### Transmissible Torque Calculation (Formula)

$$TC = \frac{P_{\text{total}} - P_{\text{pre-load}}}{0.54} \times 0.12 \times \frac{d}{2000}$$

Screw Size $d_b$	Pressure on each screw $P_b$ [N]		
	Grade 8.8 class	Grade 10.9 class	Grade 12.9 class
M4	3,900	5,450	6,550
M5	6,350	8,950	10,700
M6	9,000	12,600	15,100
M8	16,500	23,200	27,900
M10	26,200	36,900	44,300
M12	38,300	54,000	64,500

※ If more than 2pcs of SAPL-R are mounted simultaneously, the clamping force on shaft (permissible torque) becomes higher.

- SAPL-R/ 1pc mounted:  $T_c$  (Max. Permissible Torque)
- SAPL-R/ 2pcs mounted:  $T_c$  (Max. Permissible Torque) x 1.55
- SAPL-R/ 3pcs mounted:  $T_c$  (Max. Permissible Torque) x 1.85
- SAPL-R/ 4pcs mounted:  $T_c$  (Max. Permissible Torque) x 2.02

# SAPL-R SERIES : SAPL-R

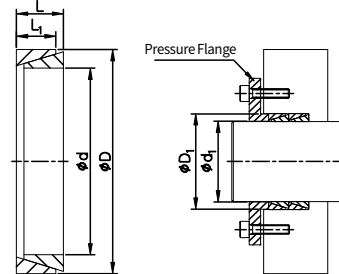

## Dimensions / Performance

Model d x D	Size(±0.3mm)		Initial Clamping Force P <sub>pre-load</sub> (N)	W* (mm)				Pressure Flange		Surface Pressure (MPa)		Mass(g)
	L <sub>1</sub>	L		1 set	2 set	3 set	4 set	d <sub>1</sub>	D <sub>1</sub>	Shaft(Pi)	Hub(Po)	
SAPL-R-6 x 9	3.7	4.5	8,400	2.5	2.5	3	4	6.1	8.9	115	75	2
SAPL-R-7 x 10	3.7	4.5	8,200	2.5	2.5	3	4	7.1	9.9	105	70	2
SAPL-R-8 x 11	3.7	4.5	7,700	2.5	2.5	3	4	8.1	10.9	120	90	2
SAPL-R-9 x 12	3.7	4.5	7,650	2.5	2.5	3	4	9.1	11.9	140	105	2
SAPL-R-10 x 13	3.7	4.5	7,000	2.5	2.5	3	4	10.1	12.9	135	105	2
SAPL-R-11 x 14	3.7	4.5	7,000	2.5	2.5	3	4	11.1	13.9	115	90	2
SAPL-R-12 x 15	3.7	4.5	7,000	2.5	2.5	3	4	12.1	14.9	115	90	2
SAPL-R-13 x 16	3.7	4.5	6,500	2.5	2.5	3	4	13.1	15.9	110	90	2
SAPL-R-14 x 18	5.3	6.3	11,000	3.5	3.5	4.5	5.5	14.1	17.9	115	85	5
SAPL-R-15 x 19	5.3	6.3	10,800	3.5	3.5	4.5	5.5	15.1	18.9	110	85	5
SAPL-R-16 x 20	5.3	6.3	10,000	3.5	3.5	4.5	5.5	16.1	19.9	105	85	6
SAPL-R-17 x 21	5.3	6.3	9,600	3.5	3.5	4.5	5.5	17.1	20.9	105	80	6
SAPL-R-18 x 22	5.3	6.3	9,150	3.5	3.5	4.5	5.5	18.1	21.9	100	110	7
SAPL-R-19 x 24	5.3	6.3	12,500	3.5	3.5	4.5	5.5	19.2	23.8	140	105	7
SAPL-R-20 x 25	5.3	6.3	12,000	3.5	3.5	4.5	5.5	20.2	24.8	135	115	9
SAPL-R-22 x 26	5.3	6.3	9,000	3.5	3.5	4.5	5.5	22.2	25.8	135	110	7
SAPL-R-24 x 28	5.3	6.3	8,400	3.5	3.5	4.5	5.5	24.2	27.8	130	95	8
SAPL-R-25 x 30	5.3	6.3	10,000	3.5	3.5	4.5	5.5	25.2	29.8	115	100	9
SAPL-R-28 x 32	5.3	6.3	7,500	3.5	3.5	4.5	5.5	28.2	31.8	115	85	10
SAPL-R-30 x 35	5.3	6.3	8,600	3.5	3.5	4.5	5.5	30.2	34.8	100	115	11
SAPL-R-32 x 36	5.3	6.3	7,900	3.5	3.5	4.5	5.5	32.2	35.8	130	110	11
SAPL-R-35 x 40	6	7	10,000	3.5	3.5	4.5	5.5	35.2	39.8	125	100	16
SAPL-R-36 x 42	6	7	11,700	3.5	3.5	4.5	5.5	36.2	41.8	115	95	19
SAPL-R-38 x 44	6	7	11,000	3.5	3.5	4.5	5.5	38.2	43.8	110	105	21
SAPL-R-40 x 45	6.6	8	13,900	3.5	4.5	5.5	6.5	40.2	44.8	115	95	21
SAPL-R-42 x 48	6.6	8	15,550	3.5	4.5	5.5	6.5	42.2	47.8	110	95	26
SAPL-R-45 x 52	8.6	10	28,300	3.5	4.5	5.5	6.5	45.2	51.8	105	135	45
SAPL-R-48 x 55	8.6	10	24,700	3.5	4.5	5.5	6.5	48.2	54.8	155	130	43
SAPL-R-50 x 57	8.6	10	23,600	3.5	4.5	5.5	6.5	50.2	56.8	150	125	45

- Pt(Max. Permissible Thrust Load) indicates values at the zero(0) torque, and Tc(Max. Permissible Torque) at the zero(0) thrust load respectively. In case torque and thrust load occur simultaneously, please refer to the formula in the [Selection guide] page for combined load calculation.
- For the best performance, make sure all foreign substances e.g. corrosion, dust etc. are removed from each surface of shaft, hub, and A.P. Lock's inner and outer ring.
- W\*: Distance(W) between pressure flange and hub/shaft when several pieces of SAPL-R are mounted simultaneously.

# A.P. LOCK : SAPC SERIES

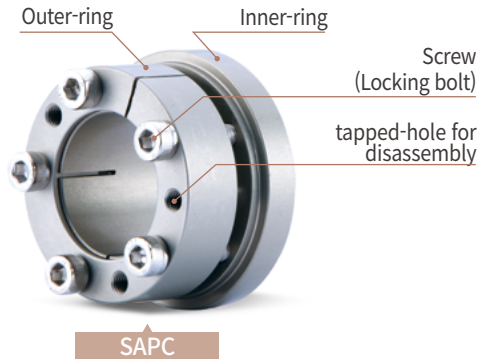

## Structure and Material for SAPC Series

Model	Body (Inner-ring / Outer-ring)		Screw(Locking bolt)	
	Material	Surface Treatment	Material	Surface Treatment
SAPC	AL-7075-T6	Anodizing	SCM435	Electroless Nickel Plating

## Product Features

- Excellent for high rotating application (AL-Alloy Material has lower moment of inertia)
- The most optimal solution with AL Pulley (Lower surface pressure, less shape distortion) comparing to Steel A.P. Lock
- Adequate surface pressure for power transmission from servo motors with less quantity of fastening screws comparing to Steel body A.P. Lock series
- Self pressure plate function through the unique structure, without requiring an additional part to press bearings
- Designed to suit clean rooms with high corrosion resistance feature

## Principles

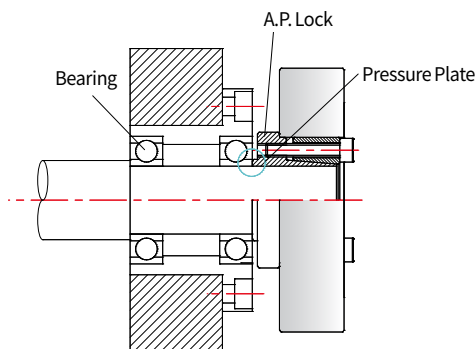

## How to Order

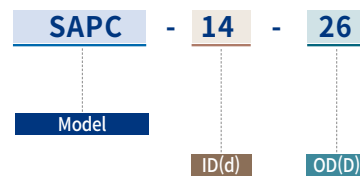

# SAPC SERIES : SAPC

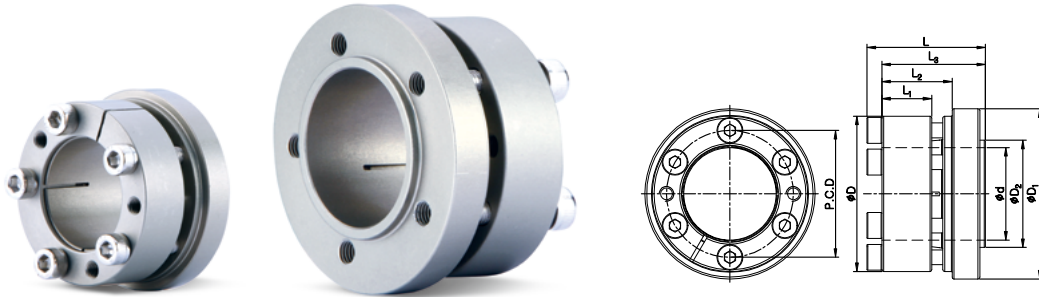

## Dimensions / Performance

Model d x D	Size (±0.3mm)							Max. Permissible Torque(Tc) (N·m)	Max. Permissible Thrust Load(Pt) (kN)	Surface Pressure (MPa)		Screw(Locking bolt)			Mass(g)
	L	L <sub>1</sub>	L <sub>2</sub>	L <sub>3</sub>	D <sub>1</sub>	D <sub>2</sub>	P.C.D.			Shaft(Pi)	Hub(Po)	Size	The no. of screws	Fastening Torque(N·m)	
SAPC-4-15	15.5	6.5	9	13	17.5	6.5	10.1	2	1	151	37	M2.5	4	1	6
SAPC-4-5-16	15.5	6.5	9	13	19	7.5	11.1	2.2	1	134	35	M2.5	4	1	6
SAPC-5-16	15.5	6.5	9	13	19	7.5	11.1	2.5	1	121	35	M2.5	2	1	7
SAPC-6-17	15.5	6.5	9	13	20	8.5	12.1	4	1.33	151	49	M2.5	3	1	8
SAPC-8-19	17.5	7.5	10	15	22	11	14.1	6	1.51	129	51	M2.5	4	1	11
SAPC-10-21	17.5	7.5	10	15	24	13	16.1	8	1.63	104	46	M2.5	4	1	12
SAPC-11-22	19.5	8	11	17	25	14	17.1	9	1.66	88	41	M2.5	4	1	14
SAPC-12-24	20.5	9	12	18	27	15	19.2	12	1.99	89	42	M2.5	5	1	17
SAPC-14-26	20.5	9	12	18	29	17	21.2	18	2.56	91	47	M2.5	6	1	19
SAPC-15-28	23	9.5	13	20	31	18.5	22.2	25	3.34	79	38	M3	4	1.7	24
SAPC-16-29	23	9.5	13	20	32	19.5	23.2	26	3.34	74	37	M3	4	1.7	25
SAPC-17-30	24	10	14	21	33	20.5	24	27	3.18	66	34	M3	4	1.7	28
SAPC-18-31	24	10	14	21	34	21.5	25	29	3.23	78	41	M3	5	1.7	29
SAPC-19-32	24	10	14	21	35	22.5	26	33	3.5	74	40	M3	5	1.7	30
SAPC-20-37	28	12	16	24	40	24	29.4	54	5.47	92	46	M4	4	3.5	47
SAPC-22-39	28	12	16	24	42	26	31.4	65	5.94	83	43	M4	4	3.5	52
SAPC-24-41	30	13	18	26	45	28	33.3	85	7.07	84	46	M4	5	3.5	57
SAPC-25-42	32	13.5	19	28	46	29	34.3	110	8.77	97	53	M4	6	3.5	67
SAPC-28-45	32	13.5	19	28	49	32	37.3	125	8.91	101	57	M4	7	3.5	73
SAPC-30-50	35	14.5	20	30	55	34.5	41.3	180	12.08	99	56	M5	5	8	101
SAPC-32-53	35	14.5	20	30	58	36.5	43.3	210	13.13	104	59	M5	6	8	112
SAPC-35-56	38	16	22.5	33	62	40	46.6	230	13.13	92	54	M5	6	8	134

- Pt(Max. Permissible Thrust Load) indicates values at the zero(0) torque, and Tc(Max. Permissible Torque) at the zero(0) thrust load respectively. In case torque and thrust load occur simultaneously, please refer to the formula in the [Selection guide] page for combined load calculation.
- For the best performance, make sure all foreign substances e.g. corrosion, dust etc. are removed from each surface of shaft, hub, and A.P. Lock's inner and outer ring.

# A.P. LOCK : SAPA SERIES

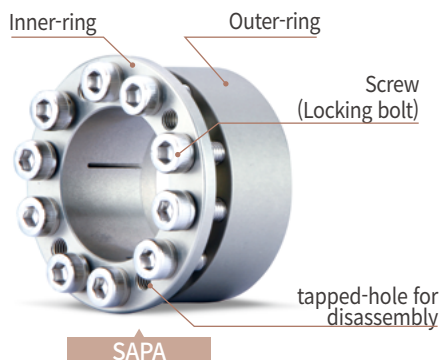

## Structure and Material for SAPA Series

Model	Body (Inner-ring / Outer-ring)		Screw(Locking bolt)	
	Material	Surface Treatment	Material	Surface Treatment
SAPA	AL-7075-T6	Anodizing	SCM435	Electroless Nickel Plating

## Product Features

- Excellent for high rotating application (AL-Alloy Material has lower moment of inertia)
- Designed to suit not only AL-Alloy pulleys but also steel ones with higher surface pressure comparing to SAPC series
- Designed to suit clean rooms with high corrosion resistance
- Exactly identical dimensions with SAPL-A Series
- Self-centering function (prevention of slight off-center matters)

## Principles

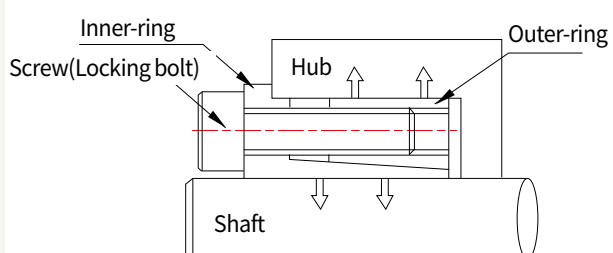

## How to Order

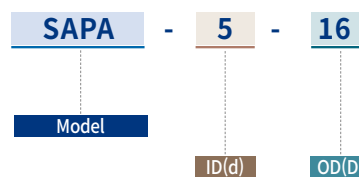

# SAPA SERIES : SAPA

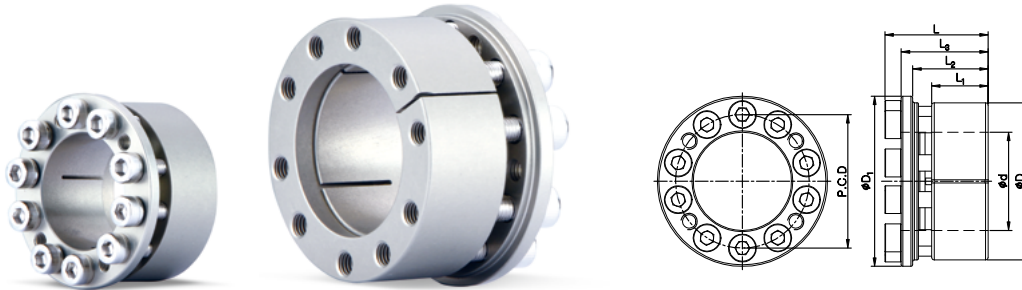

## Dimensions / Performance

Model d x D	Size (±0.3mm)						Max. Permissible Torque(Tc) (N·m)	Max. Permissible Thrust Load(Pt) (kN)	Surface Pressure (MPa)		Screw(Locking bolt)			Mass(g)
	L	L <sub>1</sub>	L <sub>2</sub>	L <sub>3</sub>	D <sub>1</sub>	P.C.D			Shaft(Pi)	Hub(Po)	Size	The no. of screws	Fastening Torque(N·m)	
SAPA-5-16	16	8	11.2	13	18.5	11.7	6	2.24	197	64	M3	4	1.7	7
SAPA-6-19	18.3	9	12.3	14.3	21.5	14	11	3.74	285	92	M4	4	3.5	10
SAPA-8-21	18.6	9.3	12.6	14.6	23.5	15.4	18	4.48	214	96	M4	4	3.5	13
SAPA-10-23	18.8	9.5	12.8	14.8	25.5	17.5	20	4.48	167	86	M4	4	3.5	15
SAPA-11-24	19.8	10.5	13.8	15.8	26.5	18.4	24	4.48	153	83	M4	4	3.5	17
SAPA-12-26	22	10.5	15.5	18	28.5	20.2	40	6.73	209	103	M4	6	3.5	20
SAPA-14-28	22	10.5	15.5	18	30.5	22.2	52	7.57	202	108	M4	6	3.5	23
SAPA-15-29	23	11.5	16.5	19	31.5	23.2	56	7.57	167	95	M4	6	3.5	25
SAPA-16-30	23.6	12	17.1	19.6	33	24.2	60	7.57	149	88	M4	6	3.5	28
SAPA-17-31	24.1	12.5	17.6	20.1	33.5	25.4	88	10.08	177	109	M4	8	3.5	28
SAPA-18-32	24.1	12.5	17.6	20.1	34.5	26.4	92	10.08	167	106	M4	8	3.5	30
SAPA-19-33	24.1	12.5	17.6	20.1	35.5	27.4	96	10.08	159	102	M4	8	3.5	31
SAPA-20-38	29.1	15.3	21.1	24.1	42	30.8	176	17.28	186	111	M5	8	8	53
SAPA-22-40	29.1	15.3	21.1	24.1	44	32.8	232	20.8	204	126	M5	8	8	60
SAPA-24-42	30.1	16.3	22.1	25.1	46	34.8	256	20.8	173	113	M5	8	8	65
SAPA-25-43	31.1	17.3	23.1	26.1	47	35.8	270	21.76	172	109	M5	8	8	68
SAPA-28-46	31.6	17.3	23.1	26.6	50	38.8	290	21.6	153	101	M5	10	8	71
SAPA-30-48	31.6	17.3	23.1	26.6	52	40.8	320	21.6	142	97	M5	10	8	76
SAPA-32-50	32.6	18.3	24.1	27.6	54	42.8	352	21.6	124	88	M5	10	8	80
SAPA-35-57	36	19.5	26	30	62	48.4	576	32.88	195	132	M6	8	13	117

- Pt(Max. Permissible Thrust Load) indicates values at the zero(0) torque, and Tc(Max. Permissible Torque) at the zero(0) thrust load respectively. In case torque and thrust load occur simultaneously, please refer to the formula in the [Selection guide] page for combined load calculation.
- For the best performance, make sure all foreign substances e.g. corrosion, dust etc. are removed from each surface of shaft, hub, and A.P. Lock's inner and outer ring.

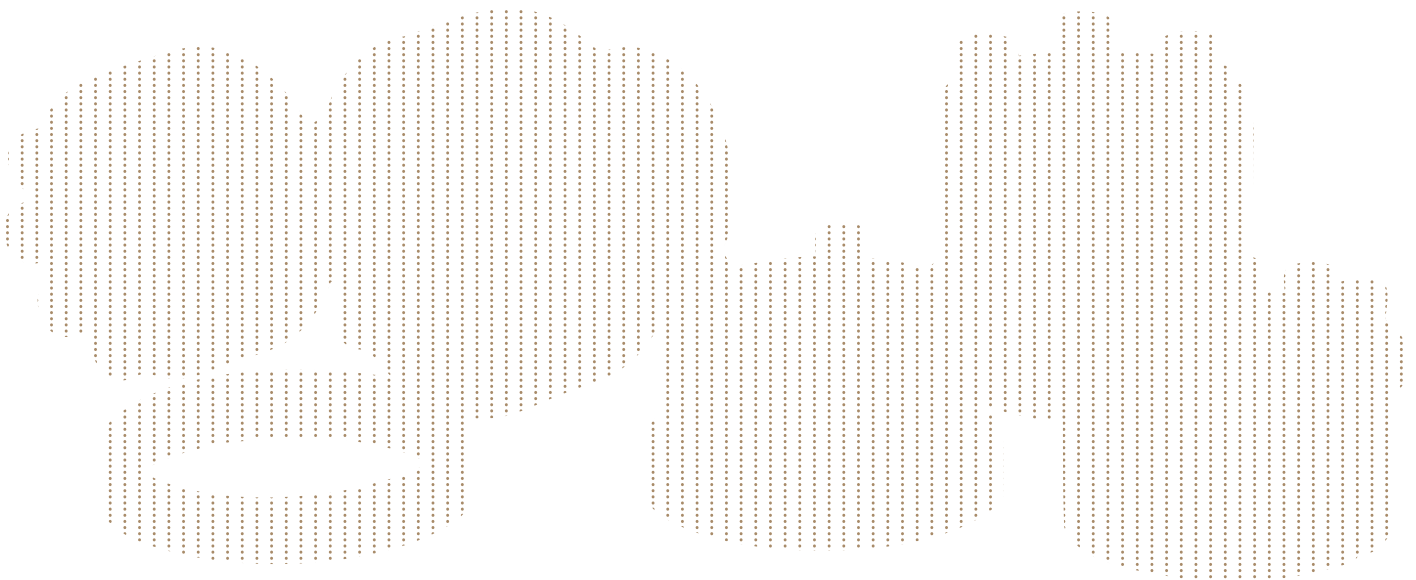

# SUPPORT UNIT FOR BALL SCREW

## Overview

Index (Support Unit for Ball Screw)	232p
Installation Guide	233p
Made-To-Order Process	234~235p

## Dimensions / Performance

### Motor Bracket Unit

▪ Product Features and Classification	236p
▪ Structure and Bearing Combinations	237p
▪ Recommended Motor Bracket Units according to Servo Motors	238p
▪ Recommended Couplings according to Motor Bracket Units	238p
▪ How To Order	239p
▪ Recommended Shape of Ball Screw Shaft-end	240p
▪ C-SBU series	241p
▪ O-SBU series	242p
▪ E-SBU series	243p
▪ M-SBU series	244p
▪ S-SBU series	245p

### Support Unit

Product Features and Classification	246p
Support Unit (General Load)	
▪ Structure and Bearing Combinations	247p
▪ How To Order / Precautions for Supported-side Installation	248p
▪ List of Bearings / Product Recommendation by Ball Screw Outer Diameters	249p
▪ Recommended Shape of Ball Screw Shaft-end	250~251p
▪ EK/EF Series	252~253p
▪ BK/BF Series	254~255p
▪ AK/AF Series	256p
▪ FK/FF Series	257~259p
▪ CK/CF Series	260p
▪ WBK Series (Miniature type)	261p

### High-load Type Support Unit

▪ Structure and Bearing Combinations / How To Order	262~263p
▪ List of Bearings	264p
▪ Recommended Shape of Ball Screw Shaft-end	265p
▪ SWBK Series	266p
▪ HBK Series	267p

### Grease-Injection Type Support Unit

▪ Structure / Product Features / How To Order	268p
▪ How to Inject Grease	269p
▪ Recommended Shape of Ball Screw Shaft-end	270p
▪ BK-G Series	271p
▪ FK-G Series	272p
▪ SWBK-G Series	273p

## Dimensions / Performance

### Support Unit (For TM Screw)

▪ Features, Classification and How To Order	274p
▪ Recommended Shape of TM Screw Shaft-end	275p
▪ ET/EF Series	276p

### Lock-Nut

▪ RN Series (General Load)	277p
▪ RNSS Series (General Load)	278p
▪ RNSB Series (General Load)	279p
▪ ZN Series (General Load)	280p
▪ HLRN Series (High Load)	281p

### Bearing Unit

▪ SBS Series	282p
▪ SBD Series	282p





# INDEX (SUPPORT UNIT FOR BALL SCREW)

Motor Bracket Unit							
Series	C-SBU	O-SBU	E-SBU	M-SBU	S-SBU		
Use for	FIXED SIDE (CLEAN)	FIXED SIDE (OPEN)	FIXED SIDE (ECONOMY)	FIXED SIDE (COMPACT)	SUPPORTED SIDE		
Shape							
Page	241p	242p	243p	244p	245p		
Ball Screw Support Unit							
Series	EK	EF	BK	BF	AK	AF	
Use for	FIXED SIDE	SUPPORTED SIDE	FIXED SIDE	SUPPORTED SIDE	FIXED SIDE	SUPPORTED SIDE	
Shape							
Page	252p	253p	254p	255p	256p	256p	
Ball Screw Support Unit							
Series	FK	FF	CK	CF	WBK		
Use for	FIXED SIDE	SUPPORTED SIDE	FIXED SIDE	SUPPORTED SIDE	FIXED SIDE (MINIATURE)		
Shape							
Page	257 ~ 258p	259p	260p	260p	261p		
Ball Screw Support Unit							
Series	SWBK	HBK	BK-G	FK-G	SWBK-G	ET	
Use for	FIXED SIDE (HIGH LOAD)		FIXED SIDE (GREASE-INJECTION TYPE)			FIXED SIDE	
Shape							
Page	266p	267p	271p	272p	273p	276p	
Lock-Nut				Bearing Unit			
Series	RN	RNSS	RNSB	ZN	HLRN	SBS	SBD
Shape							
Page	277p	278p	279p	280p	281p	282p	282p

# SUPPORT UNIT

## SUPPORT UNIT FOR BALL SCREW

### Installation Guide

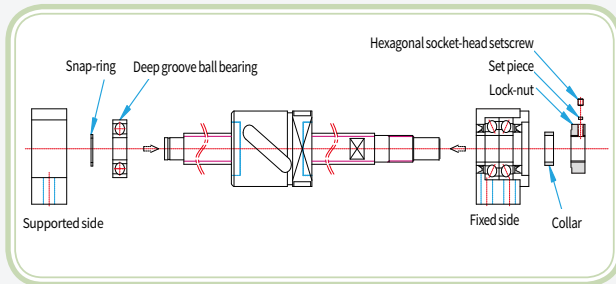

### Installation of Support Unit with Ball Screw

1. Mount ball screw onto fixed side support unit.
  - The support unit must not be disassembled.
  - Make sure the oil-seal ring is not folded when the shaft-end is pushed towards the bearing.
  - Fasten set-screws of lock-nut after assembling collars.
  - Mount a nut bracket onto the nut of ball screw.
2. Mount the deep groove ball bearing (of supported side support unit) onto the ball screw shaft-end, and fix with a snap-ring to secure and then insert the assembly to the housing of supported side support unit.

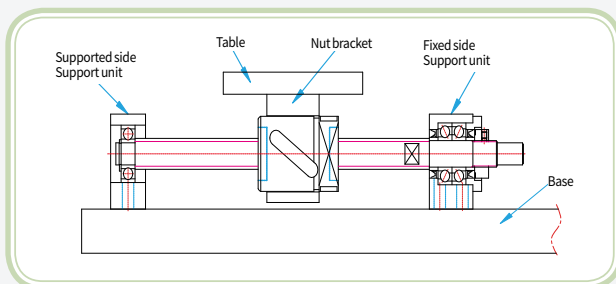

### Assembly with the Table & Base

1. Assemble the table with the nut bracket of ball screw.
2. Mount the fixed side support unit temporarily with the base.
  - If the fixed side support unit is used as a reference point, make sure there is clearance secured between the outer diameter of ball screw nut and table. (or inner diameter of bracket)
  - If the table is used as a reference point, adjust height with shims for square shaped support unit or secure clearance between outer and inner diameter of inserted area for round shaped support unit.
3. Mount the supported side support unit temporarily with the base.

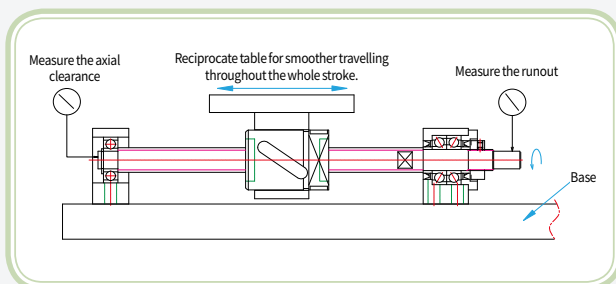

### Checking Accuracy & Fastening Fully

1. Shift the table towards the center of the shaft and make it reciprocate between both ends so that motion is adjusted running in line as smoothly as possible.
2. Measure the runout of the ball screw shaft-end and axial end-play by using a dial gauge. In the meantime, fully fasten in the following order, the nut bracket with the table, fixed side support unit and base, supported side support unit and base.

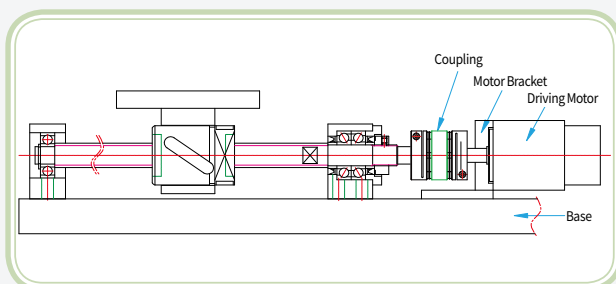

### Connection with the Driving Motor

1. Fully mount the motor bracket to the base accurately aligning with the ball screw.
2. Connect the motor and the ball screw with a coupling.
3. Operate the motor trial-run at a slow speed to make sure the assembly is accurately done.

# SUPPORT UNIT

## SUPPORT UNIT FOR BALL SCREW

### Made-To-Order Process

Sung-il Machinery can conduct Made-To-Order processes (customization) upon our customer's requests.

#### Various Materials/Surface Treatment Options



Standard



Low-temperature  
Black Chrome Plating (Raydent)



Stainless Steel



Electroless Nickel Plating

Material	Steel	Stainless Steel	High Strength Aluminum Alloy
Surface Treatment	Black Oxide Electroless Nickel Plating Low-temperature Black Chrome Plating Fluorinated Low-temperature Chrome Plating	Electropolishing	Anodizing Electroless Nickel Plating

#### Non-standard Shape Design Support

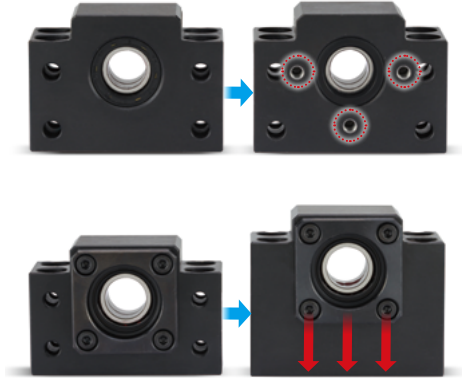

Modified Design  
(e.g. additional tapped-holes, changed height etc.)



Custom Pin Holes on Reference Surfaces  
for Assembly Efficiency



- Changes in Bearing Specifications and Arrangement Based on Load
- Addition of Reference Surfaces for Housing Installation and Tolerance Specification
- Other Special Shapes That Meet Customer Equipment Specifications

※ For these Made-To-Order processes above, please contact Sung-il Customer Service team prior to firm order placement, in order to discuss accurate specification/design.





# SUPPORT UNIT

## SUPPORT UNIT FOR BALL SCREW

### Made-To-Order Process

#### Various Grease Options

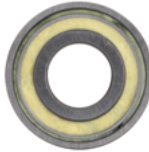
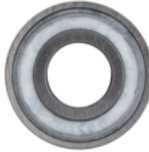
The grease can be replaced with suitable alternatives depending on the equipment's application. By using grease that matches the intended purpose, potential issues such as thermal degradation, carbonization, and dust generation can be minimized.

Grease Model	LG2	AFE-CA	AFF	HT-Z1	NBU-15	XL-600
Manufacturer	NSK	THK	THK	KOREA TAU	KLUBER	THERMAL-LUBE
Mark	AG	AE	AF	AH	AN	AX
Application	Low dust generation (Clean)				High speed	High temperature
Temperature	-20 ~ +70 °C	-40 ~ +180 °C	-40 ~ +120 °C	-40 ~ +170 °C	-40 ~ +130 °C	-17 ~ +399 °C
Color	White 	White 	Reddish Brown 	Yellow 	Beige 	Brown 

※ For detailed information on each type of grease, please refer to the catalogue from the grease manufacturer.

※ Other greases specified by the customer can also be applied. Please contact customer service for inquiries.

※ When changing the grease, the specifications of the bearings applied to the product may change.

#### Example of How To Order When Changing Bearing Grease

Please indicate the mark of the grease to be applied next to each product name.

For detailed ordering methods for each product, please refer to the "How To Order" introduction pages.

#### Support Unit

	Fixed Side	Supported Side
Example.1	FK-15-G P0-C7-RA- <b>AE</b>	BF-15-RA- <b>AE</b>
Example.2	BK-10 P5- <b>AH</b>	BF-10- <b>AH</b>

#### Motor Bracket Unit

	Fixed Side	Supported Side
Example.1	C-SBU-10.40.4 P0-C7-RB- <b>AH</b>	S-SBU-10.40-BA-D- <b>AH</b>
Example.2	O-SBU-15.60.5 C8-NW- <b>AN</b>	S-SBU-15.60-NI- <b>AN</b>

# MOTOR BRACKET UNIT

## MOTOR BRACKET UNIT

### Product Features

- ▶ **Precision:** The combined structure of the ball screw mounting and servo motor mounting prevents errors during installation.
- ▶ **Convenience:** The product is designed to be easy to install and design, as it is available in a variety of specifications to suit a wide range of servo motors.
- ▶ **Economy:** The product is more cost-effective and time-saving than the structure that separately designs the support unit and motor bracket.
- ▶ **Surface treatment:** Various surface treatments are available (anodizing, electroless nickel plating, raydent, etc.)

### Product Classification

Fixed Side	C-SBU	Clean		
	O-SBU	Open		
	E-SBU	Economy		
	M-SBU	Compact		
Supported Side	S-SBU	Default		
		Damper-attached		

# MOTOR BRACKET UNIT

## MOTOR BRACKET UNIT

### Structure

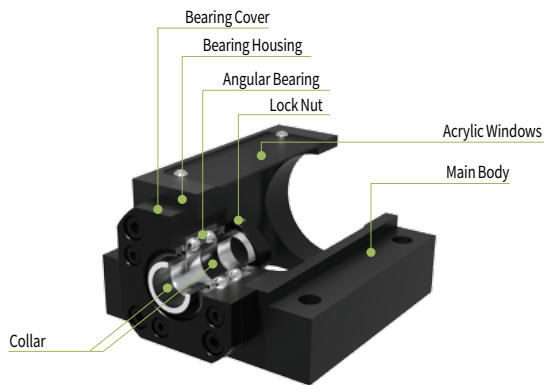

#### Fixed Side

- Full range with high accuracy and without runout, achieved by applying an adequate preload in advance.
- Various product type options:
  - └ Support unit mounted type / Bearing mounted type
  - └ Clean (closed) type / Open type
- Accompanied by high-accuracy lock-nut and collars (spacer).

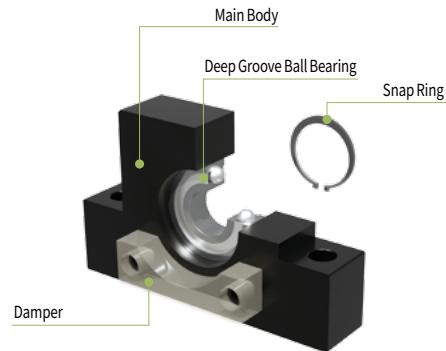

#### Supported Side

- Accompanied by a deep-groove ball bearing and a snap-ring.
- The damper-attached type is optional.

### Bearing Combinations

#### 1. Arrangement types of angular contact ball bearing combinations

- 1) DB combination (back to back): The large distance between the effective load centers results in higher rigidity at the moment load. However if accuracy of housing is not enough, it may produce damage e.g. flaking at a earlier stage due to the increased internal load. Preload is determined by torque when the user fastens the lock-nut.
- 2) DF combination (face to face): The small distance between effective load centers limits bearing capacity to sustain moment load, however it performs at a better level to absorb the margin of assembly error. Preload is determined at maker's assembly of bearing cover, thus this way allows easier self-management for users.

#### 2. Standard arrangement type of Sung-il products is DF combination.

- ※ In any case DB combination type is requested, please contact Sung-il Customer Service team for further assistance.

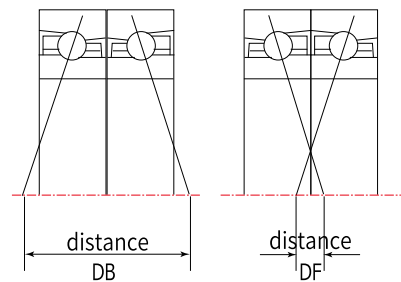

# MOTOR BRACKET UNIT

## MOTOR BRACKET UNIT

### Recommended Motor Bracket Units according to Servo Motors

Motor's flange size		□25mm	□40(38)mm	□60mm	□80mm
Servo Motor Output(W) by brand	mitsubishi	10 / 20 / 30	50 / 100 / 150	100 / 200 / 300 / 400 / 600	200 / 375 / 400 / 500 / 750 / 1000
	YASKAWA	10 / 20 / 30	50 / 100 / 150	100 / 200 / 400 / 600	200 / 400 / 750 / 1000
	PANASONIC	-	50 / 100	100 / 200 / 400	200 / 400 / 750 / 1000
	LS Mecapion	-	50 / 100 / 150	100 / 200 / 400	300 / 400 / 450 / 550 / 600 / 650 / 750 / 1000
	NIDEC SANKYO	-	50 / 100	200 / 400	750 / 1000
	SANYO DENKI	-	30 / 50 / 100	100 / 200 / 400	200 / 400 / 750
	OMRON	-	50 / 100	200 / 400	750
Recommended Motor Bracket Unit		SBU-4.25.2.5 SBU-5.25.2.5 SBU-6.25.2.5	SBU-8.40.4 / SBU-8.38.3 SBU-10.40.4 / SBU-10.38.3 SBU-12.40.4 / SBU-12.38.3	SBU-12.60.5 SBU-15.60.5 SBU-20.60.5	SBU-15.80.6 SBU-20.80.6

### Recommended Couplings according to Motor Bracket Units (Fixed-side)

Model	Motor's specification			Recommended coupling			
	Flange size (mm)	Output (W)	Max. Peak Torque (N·m)	SHR series	Permissible Torque (N·m)	SD/SAD series	Permissible Torque (N·m)
□-SBU-4	20	N/A (Stepper Motor)	0.1	SHR-14C	1	SDWB-16C	0.6
	25	10 ~ 30	0.1	SHR-14C	1	SDWB-16C	0.6
□-SBU-5	20	N/A (Stepper Motor)	0.1	SHR-14C	1	SDWA-16C	0.6
	25	10 ~ 30	0.1	SHR-14C	1	SDWA-16C	0.6
□-SBU-6	20	N/A (Stepper Motor)	0.1	SHR-14C	1	SDWB-16C	0.6
	25	10 ~ 30	0.1	SHR-14C	1	SDWB-16C	0.6
	28	N/A (Stepper Motor)	0.2	SHR-14C	1	SDWB-16C	0.6
□-SBU-8	38 / 40	50 ~ 100	0.95	SHR-18C	1.9	SADW-19C	1.3
□-SBU-10	38 / 40	30 ~ 50	0.56	SHR-18C	1.9	SADW-19C	1.3
		50 ~ 150	1.7	SHR-24C	3.5	SADW-27C	3
□-SBU-12	38 / 40	30 ~ 150	1.7	SHR-24C	3.5	SADW-27C	3
		60	200 ~ 400	4.5	SHR-29C	5.7	SADW-32C
			600	6.7	SHR-33C	7	SADW-35C
□-SBU-15	60	200 ~ 400	4.5	SHR-29C	5.7	SADW-32C	4.5
		600	6.7	SHR-33C	7	SADW-35C	6
	80	500 ~ 1000	11	SHR-38C	12	SADW-40C	12
□-SBU-20	60	200 ~ 600	6.7	SHR-38C	12	SADW-40C	12
	80	500 ~ 1000	11	SHR-38C	12	SADW-40C	12

# MOTOR BRACKET UNIT

## MOTOR BRACKET UNIT

### How to Order

#### Fixed Side

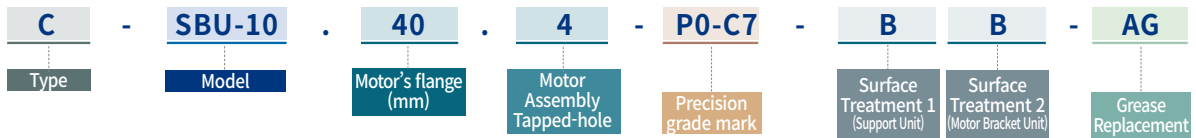

Initial	Type	Precision grade	Mark (Fixed Side Only)	Bearing precision grade	Preload
C	Clean (Closed)		P5	P5	Medium
O	Open		C8	General	Medium
E	Economy		P0-C7	General	Light
M	Compact				

Surface Treatment	Mark	Surface Treatment 1 (Support Unit)	Mark	Surface Treatment 2 (Motor Bracket Unit)
	B	BK, Black Oxide	B	BA, Black Anodizing
	N	NI, Electroless Nickel Plating	W	WA, White Anodizing
	R	RA, Low temperature Black Chrome Plating (Raydent)	N	NI, Electroless Nickel Plating

Grease Model	Standard	LG2	AFE-CA	AFF	HT-Z1	NBU-15	XL-600
Mark	No mark	AG	AE	AF	AH	AN	AX

#### Supported Side

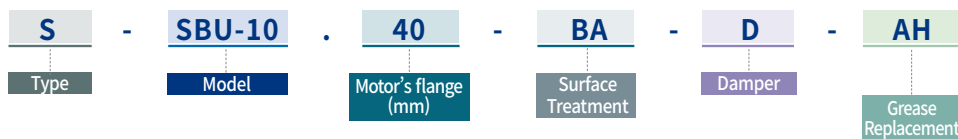

Damper (Optional)	Mark	Damper-attached	Surface Treatment	Mark	Surface Treatment
	no mark	Not attached		BA	Black Anodizing
	D	Attached		WA	White Anodizing
			NI	Electroless Nickel Plating	

Grease Model	Standard	LG2	AFE-CA	AFF	HT-Z1	NBU-15	XL-600
Mark	No mark	AG	AE	AF	AH	AN	AX

※ For detailed information regarding grease replacement, please refer to the guideline pages in the catalogue under the "Made-To-Order Process."

# MOTOR BRACKET UNIT

## MOTOR BRACKET UNIT

### Recommended Shape of Ball Screw Shaft-end (Fixed-side)

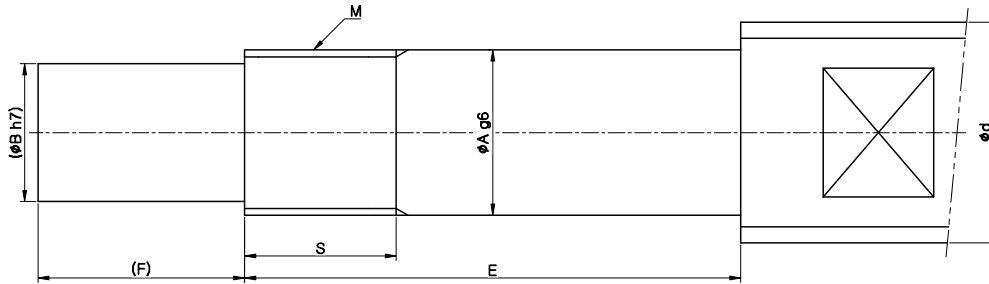

Dimensions(mm)															Lock-nut	
d	A	B	C-SBU			O-SBU			E-SBU			M-SBU			Model	Size M × pitchpitch
			E	F	S	E	F	S	E	F	S	E	F	S		
Ø6	6	3	-	-	-	-	-	-	23	8	7.5	23	8	7.5	RN-4	M4×0.5
Ø8	8	4	-	-	-	-	-	-	24/25	10	8	24/25	10	8	RN-5	M5×0.5
			-	-	-	-	-	-	30	10	8	30	12	8	RN-6	M6×0.75
Ø10-Ø12	8	6	35	9	10	35	9	10	35	9	10				RN-8	M8×1 / 0.75
Ø10-Ø15	10	8	36	15	11	36	15	11	36	15	11				RN-10	M10×1 / 0.75
Ø14-Ø18	12	10	36	15	11	36	15	11	36	15	11				RN-12	M12×1
Ø20	15	12	49	20	13	49	20	13	49	20	13				RN-15	M15×1
Ø25-Ø28	20	17	64	25	17	64	25	17	-	-	-				RN-20	M20×1

※ For □-SBU-5 products, the E dimension varies depending on the bearing grade: P5=24, P0-C7=25.

### Recommended Shape of Ball Screw Shaft-end (Supported-side)

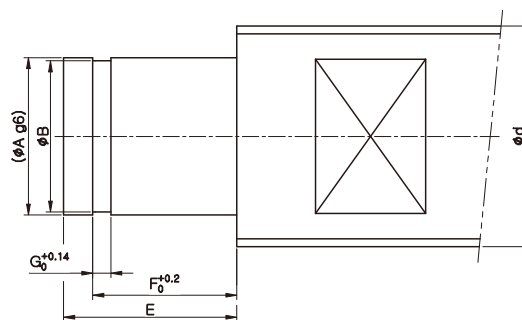

Dimensions(mm)						
d	S-SBU	A	E	B	F	G
Ø6	S-SBU-4	4	8	3.8	5.5	0.5
Ø8	S-SBU-5	5	8	4.8	5.7	0.7
	S-SBU-6	6	9	5.7	6.8	0.8
Ø10-Ø12	S-SBU-8	6	9	5.7	6.8	0.8
Ø10-Ø15	S-SBU-10	8	10	7.6	7.9	0.9
Ø14-Ø18	S-SBU-12	10	11	9.6	9.15	1.15
Ø20	S-SBU-15	15	13	14.3	10.15	1.15
Ø25-Ø28	S-SBU-20	20	19	19	15.35	1.35

# MOTOR BRACKET UNIT : C-SBU SERIES

## MOTOR BRACKET UNIT (FIXED-SIDE / CLEAN TYPE)

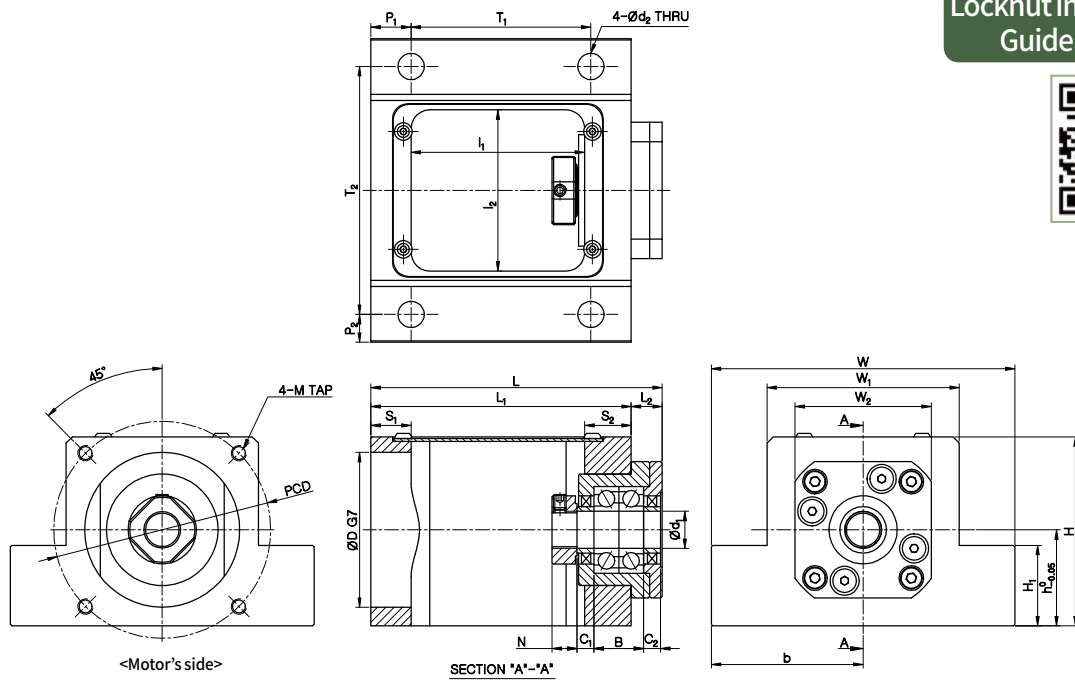

Locknut Installation  
Guide Video ▶



### Dimensions

Model	Sizes (mm)														
	d <sub>1</sub>	D	W	H	L	h	b	W <sub>1</sub>	W <sub>2</sub>	M	PCD	N	B	C <sub>1</sub>	C <sub>2</sub>
C-SBU-8.38.3	8	30	64	41	76	21	32	40	35	M3 DP8	45	6.5	14	7.5	5.5
C-SBU-8.40.4	8	30	64	41	76	21	32	40	35	M4 DP10	46	6.5	14	7.5	5.5
C-SBU-10.38.3	10	30	70	46	84	25	35	42	42	M3 DP8	45	8	16	5.5	5.5
C-SBU-10.40.4	10	30	70	46	84	25	35	42	42	M4 DP10	46	8	16	5.5	5.5
C-SBU-12.38.3	12	30	72	47	84	25	36	44	44	M3 DP8	45	8	16	5.5	5.5
C-SBU-12.40.4	12	30	72	47	84	25	36	44	44	M4 DP10	46	8	16	5.5	5.5
C-SBU-12.60.5	12	50	98	61	94	31	49	62	44	M5 DP15	70	8	16	5.5	5.5
C-SBU-15.60.5	15	50	98	61	112	31	49	62	52	M5 DP13	70	8	18	10	10
C-SBU-15.80.6	15	70	128	82	121	41	64	82	52	M6 DP15	90	8	18	10	10
C-SBU-20.60.5	20	50	116	70	139	35	58	70	68	M5 DP13	70	11	28	11	11
C-SBU-20.80.6	20	70	128	82	149	41	64	82	68	M6 DP15	90	11	28	11	11

Model	Sizes (mm)												
	d <sub>2</sub>	P <sub>1</sub>	P <sub>2</sub>	T <sub>1</sub>	T <sub>2</sub>	H <sub>1</sub>	L <sub>1</sub>	L <sub>2</sub>	l <sub>1</sub>	l <sub>2</sub>	S <sub>1</sub>	S <sub>2</sub>	
C-SBU-8.38.3	5.5	10	6	47	52	19	67	9	41	30	12	14	
C-SBU-8.40.4	5.5	10	6	47	52	19	67	9	41	30	12	14	
C-SBU-10.38.3	6.5	10	7	54	56	23	74	10	49	34	10	15	
C-SBU-10.40.4	6.5	10	7	54	56	23	74	10	49	34	10	15	
C-SBU-12.38.3	6.5	10	7	54	58	23	74	10	49	34	11	14	
C-SBU-12.40.4	6.5	10	7	54	58	23	74	10	49	34	11	14	
C-SBU-12.60.5	8.5	13	9	58	80	26	84	10	56	52	13	15	
C-SBU-15.60.5	8.5	13	9	71	80	26	97	15	63.5	52	16	17.5	
C-SBU-15.80.6	8.5	16	11	74	106	36	106	15	69	72	17	20	
C-SBU-20.60.5	10.5	20	11	77	94	30	117	22	68	60	19	30	
C-SBU-20.80.6	10.5	20	11	87	106	36	127	22	73	72	24	30	

※ Please use the jig included in the product package when assembling lock nuts for flange sizes 38mm and 40mm. For more detailed information, please refer to the instruction video or contact our customer service team.

# MOTOR BRACKET UNIT : O-SBU SERIES

## MOTOR BRACKET UNIT (FIXED-SIDE / OPEN TYPE)

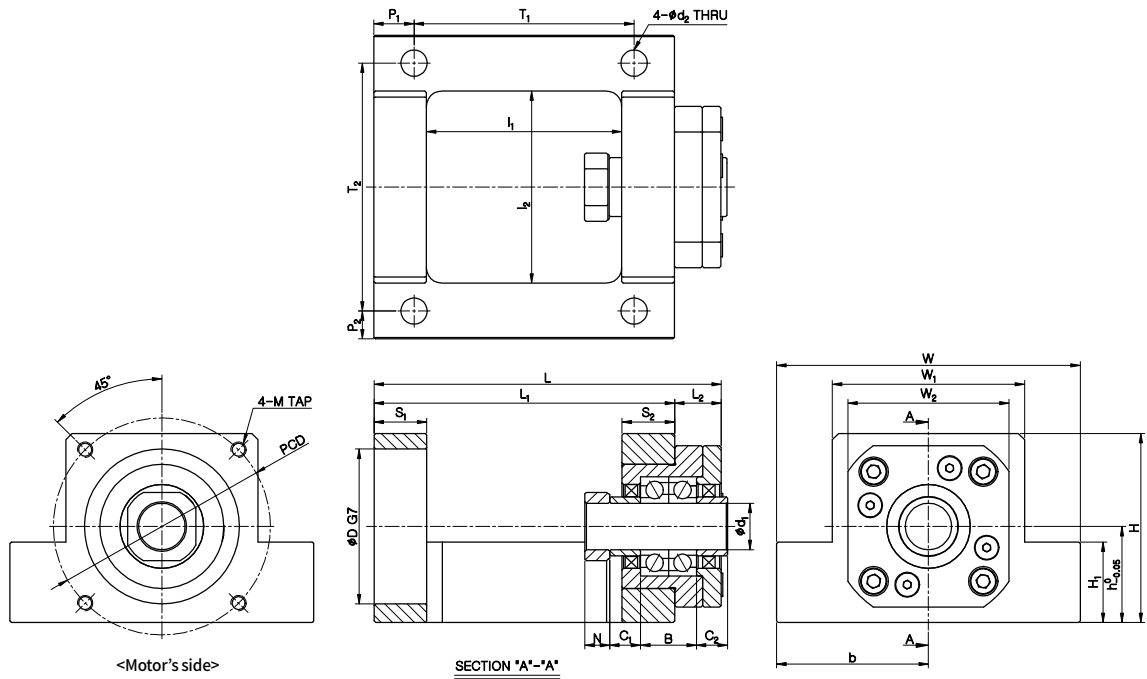

### Dimensions

Model	Sizes (mm)															
	d <sub>i</sub>	D	W	H	L	h	b	W <sub>1</sub>	W <sub>2</sub>	M	PCD	N	B	C <sub>1</sub>	C <sub>2</sub>	
O-SBU-8.38.3	8	30	64	41	76	21	32	40	35	M3 DP8	45	6.5	14	7.5	5.5	
O-SBU-8.40.4	8	30	64	41	76	21	32	40	35	M4 DP10	46	6.5	14	7.5	5.5	
O-SBU-10.38.3	10	30	70	46	84	25	35	42	42	M3 DP8	45	8	16	5.5	5.5	
O-SBU-10.40.4	10	30	70	46	84	25	35	42	42	M4 DP10	46	8	16	5.5	5.5	
O-SBU-12.38.3	12	30	72	47	84	25	36	44	44	M3 DP8	45	8	16	5.5	5.5	
O-SBU-12.40.4	12	30	72	47	84	25	36	44	44	M4 DP10	46	8	16	5.5	5.5	
O-SBU-15.60.5	15	50	98	61	112	31	49	62	52	M5 DP13	70	8	18	10	10	
O-SBU-20.80.6	20	70	128	82	149	41	64	82	68	M6 DP15	90	11	28	11	11	

Model	Sizes (mm)												
	d <sub>2</sub>	P <sub>1</sub>	P <sub>2</sub>	T <sub>1</sub>	T <sub>2</sub>	H <sub>1</sub>	L <sub>1</sub>	L <sub>2</sub>	l <sub>1</sub>	l <sub>2</sub>	S <sub>1</sub>	S <sub>2</sub>	
O-SBU-8.38.3	5.5	10	6	47	52	19	67	9	43	40	12	12	
O-SBU-8.40.4	5.5	10	6	47	52	19	67	9	43	40	12	12	
O-SBU-10.38.3	6.5	10	7	54	56	23	74	10	46	42	14	14	
O-SBU-10.40.4	6.5	10	7	54	56	23	74	10	46	42	14	14	
O-SBU-12.38.3	6.5	10	7	54	58	23	74	10	46	44	14	14	
O-SBU-12.40.4	6.5	10	7	54	58	23	74	10	46	44	14	14	
O-SBU-15.60.5	8.5	13	9	71	80	26	97	15	63	62	17	17	
O-SBU-20.80.6	10.5	20	11	87	106	36	127	22	79	82	24	24	

# MOTOR BRACKET UNIT : E-SBU SERIES

## MOTOR BRACKET UNIT (FIXED-SIDE / ECONOMY TYPE)

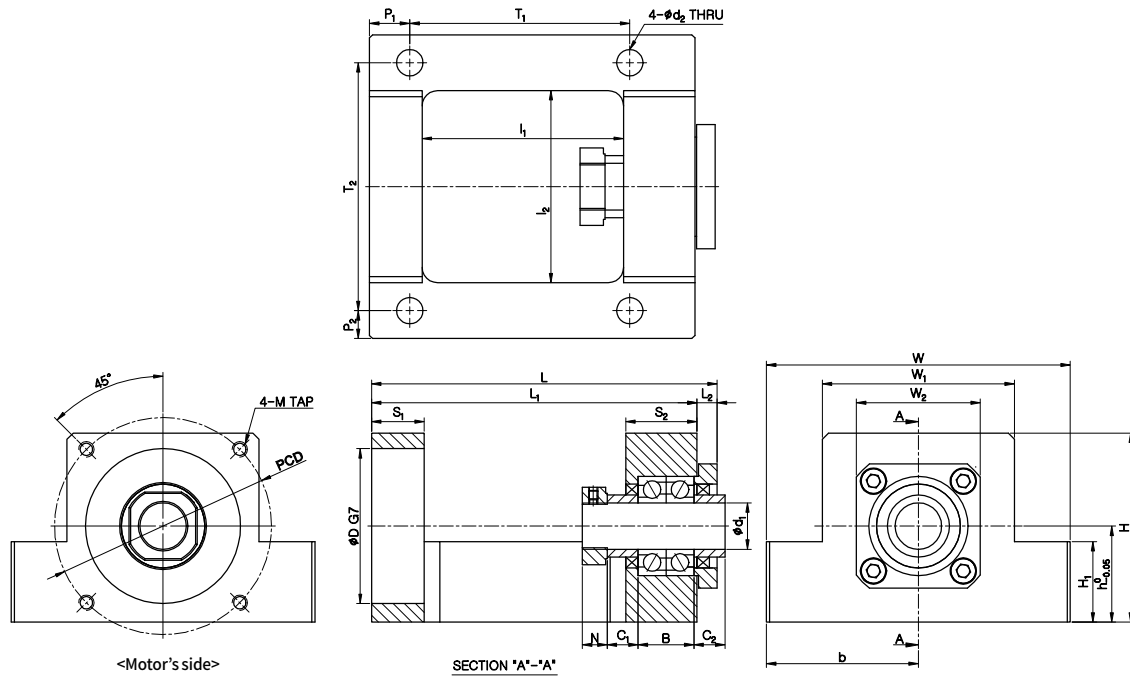

### Dimensions

Model	Sizes (mm)														
	d <sub>1</sub>	D	W	H	L	h	b	W <sub>1</sub>	W <sub>2</sub>	M	PCD	N	B	C <sub>1</sub>	C <sub>2</sub>
E-SBU-4.25.2.5 P5 / P0-C7	4	20	34	29	55.5	15.5	17	-	-	M2.5 DP7	28	5	8 / 10	4.5 / 3.5	4.5 / 3.5
E-SBU-5.25.2.5 P5 / P0-C7	5	20	34	29	55.5	15.5	17	-	-	M2.5 DP7	28	5	8 / 10	3.5 / 4.5	5.5 / 4.5
E-SBU-6.25.2.5	6	20	38	29	63.5	15.5	19	-	-	M2.5 DP7	28	5	12	7	5
E-SBU-8.38.3	8	30	64	41	79.5	21	32	40	34	M3 DP8	45	6.5	14	5.5	7.5
E-SBU-8.40.4	8	30	64	41	79.5	21	32	40	34	M4 DP10	46	6.5	14	5.5	7.5
E-SBU-10.38.3	10	30	70	46	85.3	25	35	42	36	M3 DP8	45	8	16	5.5	5.5
E-SBU-10.40.4	10	30	70	46	85.3	25	35	42	36	M4 DP10	46	8	16	5.5	5.5
E-SBU-12.38.3	12	30	72	47	85.3	25	36	44	36	M3 DP8	45	8	16	5.5	5.5
E-SBU-12.40.4	12	30	72	47	85.3	25	36	44	36	M4 DP10	46	8	16	5.5	5.5
E-SBU-15.60.5	15	50	98	61	111.5	31	49	62	40	M5 DP13	70	8	18	10	10

Model	Sizes (mm)												
	d <sub>2</sub>	P <sub>1</sub>	P <sub>2</sub>	T <sub>1</sub>	T <sub>2</sub>	H <sub>1</sub>	L <sub>1</sub>	L <sub>2</sub>	l <sub>1</sub>	l <sub>2</sub>	S <sub>1</sub>	S <sub>2</sub>	
E-SBU-4.25.2.5 P5 / P0-C7	4.5	13.5	3.75	22.5	26.5	-	55.5	-	30.5	18	9.5	15.5	
E-SBU-5.25.2.5 P5 / P0-C7	4.5	13.5	3.75	22.5	26.5	-	55.5	-	30.5	18	9.5	15.5	
E-SBU-6.25.2.5	4.5	13	4	26.5	30	-	63.5	-	34.5	21	9	20	
E-SBU-8.38.3	5.5	10	6	47	52	19	73	6.5	42	40	12	19	
E-SBU-8.40.4	5.5	10	6	47	52	19	73	6.5	42	40	12	19	
E-SBU-10.38.3	6.5	10	7	54	56	23	79	6.3	44	42	14	21	
E-SBU-10.40.4	6.5	10	7	54	56	23	79	6.3	44	42	14	21	
E-SBU-12.38.3	6.5	10	7	54	58	23	79	6.3	44	44	14	21	
E-SBU-12.40.4	6.5	10	7	54	58	23	79	6.3	44	44	14	21	
E-SBU-15.60.5	8.5	13	9	71	80	26	105	6.5	65	62	17	23	

# MOTOR BRACKET UNIT : M-SBU SERIES

MOTOR BRACKET UNIT (FIXED SIDE / COMPACT TYPE - FOR SMALL STEPPER MOTORS)

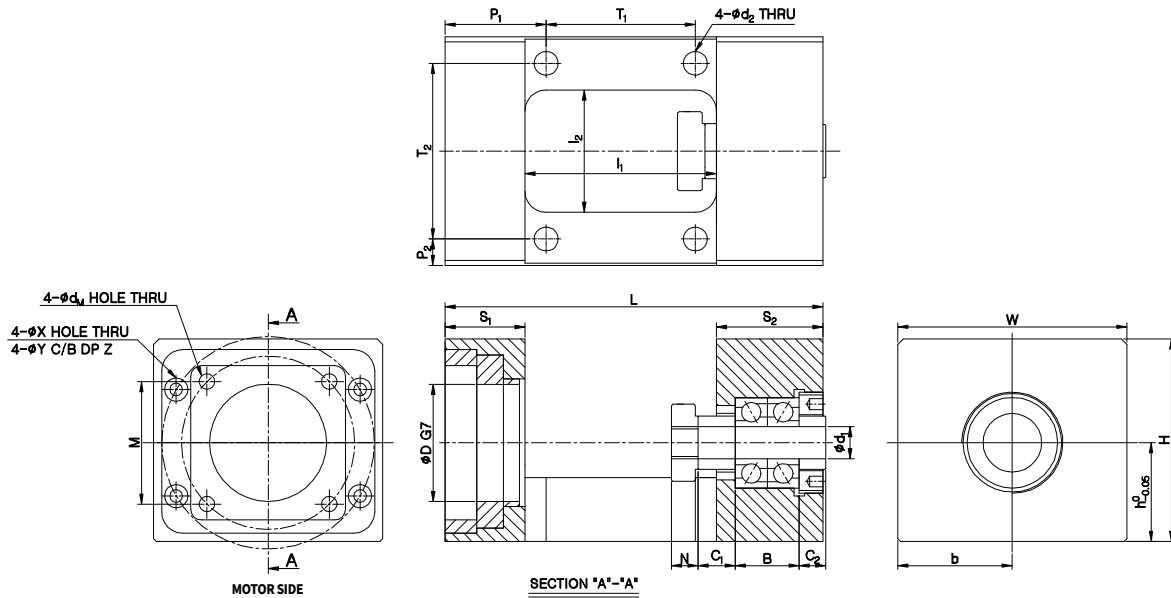

## Dimensions

Model	Sizes (mm)												
	$d_1$	D	W	H	L	h	b	$d_m$	M	N	B	$C_1$	$C_2$
M-SBU-4.20.2 P5 / P0-C7	4	15(16)	34	29	52.5	15.5	17	2.4	16	5	8 / 10	4.5 / 3.5	4.5 / 3.5
M-SBU-5.20.2 P5 / P0-C7	5	15(16)	34	29	52.5	15.5	17	2.4	16	5	8 / 10	3.5 / 4.5	5.5 / 4.5
M-SBU-6.20.2	6	15(16)	38	29	60.5	15.5	19	2.4	16	5	12	7	5
M-SBU-6.28.2.5	6	22	43	38	71	18.5	21.5	2.9	23	5	12	7	5

  

Model	Sizes (mm)												
	$d_2$	$P_1$	$P_2$	$T_1$	$T_2$	$l_1$	$l_2$	$S_1$	$S_2$	X	Y	Z	
M-SBU-4.20.2 P5 / P0-C7	4.5	10.5	4.25	22	25.5	30.5	18	6.5	15.5	2.4	4.4	2	
M-SBU-5.20.2 P5 / P0-C7	4.5	10.5	4.25	22	25.5	30.5	18	6.5	15.5	2.4	4.4	2	
M-SBU-6.20.2	4.5	10.5	4	26	30	34	21	6.5	20	2.4	4.4	2	
M-SBU-6.28.2.5	4.5	19	5	28	33	36	23	15	20	2.4	4.4	2	

※ For 20-square motors, please check the Motor Pilot Bore Diameter D ( $\phi 15$  or  $\phi 16$ ) and select the appropriate product according to the "How to order" instructions below.

※ For details on motor mounting methods, please refer to our website.

## How to Order

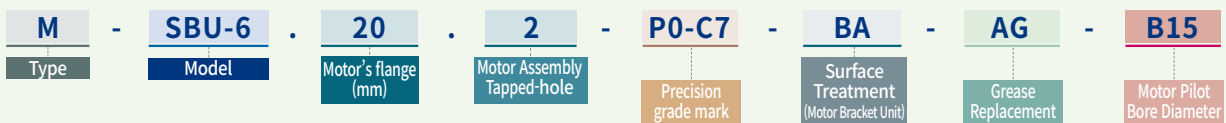

Precision grade	Mark (Fixed Side Only)			Surface Treatment	Surface Treatment (Support Unit)			Motor Pilot Bore Diameter (D G7)	Mark	Diameter
	Bearing precision grade	Preload	Mark		BA, Black Anodizing	WA, White Anodizing	NI, Electroless Nickel Plating			
	P5	Medium	B							
	P0-C7	Light	W					B15	$\phi 15$	
			N					B16	$\phi 16$	

Grease Model	Standard	LG2	AFC-CA	AFF	HT-Z1	NBU-15	XL-600
Mark	No mark	AG	AE	AF	AH	AN	AX

# MOTOR BRACKET UNIT : S-SBU SERIES

## MOTOR BRACKET UNIT (SUPPORTED-SIDE)

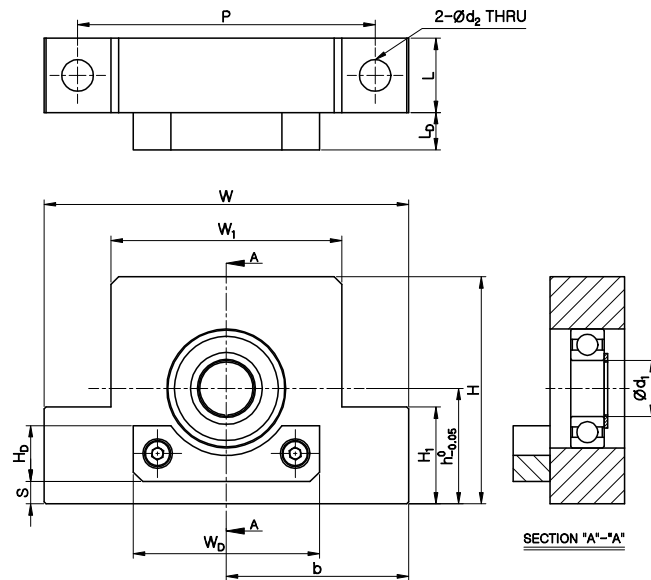

### Dimensions

Model	Sizes (mm)													
	Body										Damper (optional)			
	$d_1$	$W$	$H$	$L$	$h$	$b$	$W_1$	$H_1$	$d_2$	$P$	$W_D$	$H_D$	$L_D$	$S$
S-SBU-4.20 / 25	4	34	26	10	15.5	17	18	10	4.5	26	16	6	8	3
S-SBU-5.20 / 25	5	34	26	10	15.5	17	18	10	4.5	26	16	6	8	3
S-SBU-6.20 / 25	6	38	28	12	15.5	19	22	10	4.5	30	20	7	8	0.5
S-SBU-6.28	6	43	31	12	18.5	21.5	25	12	4.5	34	20	7	8	3.5
S-SBU-8.38 / 40	6	64	41	14	21	32	40	19	5.5	52	32	10	10	7.5
S-SBU-10.38 / 40	8	70	46	20	25	35	42	23	6.5	56	34	10	10	9
S-SBU-12.38 / 40	10	72	47	20	25	36	44	23	6.5	58	46	12	10	6
S-SBU-12.60	10	98	61	20	31	49	62	26	8.5	80	46	12	10	11.5
S-SBU-15.60	15	98	61	20	31	49	62	26	8.5	80	50	15	10	6
S-SBU-15.80	15	128	82	20	41	64	82	36	10.5	106	50	15	10	16
S-SBU-20.60	20	116	70	26	35	58	70	30	10.5	94	60	19	10	6
S-SBU-20.80	20	128	82	26	41	64	82	36	10.5	106	60	19	10	12

















# SUPPORT UNIT

## SUPPORT UNIT FOR BALL SCREW

### Product Features

- ▶ High accuracy (No need of additional adjustment)
- ▶ Simpler application design possible with standardized bearings
- ▶ Compact Structure for installing even at small and narrow areas
- ▶ Prevention of foreign material and leak of grease by the inner oil-seal rings
- ▶ Diverse finish options available (Standard: Black Oxide)

### Product Classification

General Load	Fixed Side	Square					
			EK	BK	AK	CK	BK-G
	Round						
			FK	WBK	FK-G		
	Supported Side	Square					
			EF	BF	AF	CF	
	Round						
		FF					
High Load	Fixed Side	Round			Ultra High-Load		
			SWBK	SWBK-G		HBK	

# SUPPORT UNIT

## SUPPORT UNIT FOR BALL SCREW (GENERAL LOAD)

### Structure

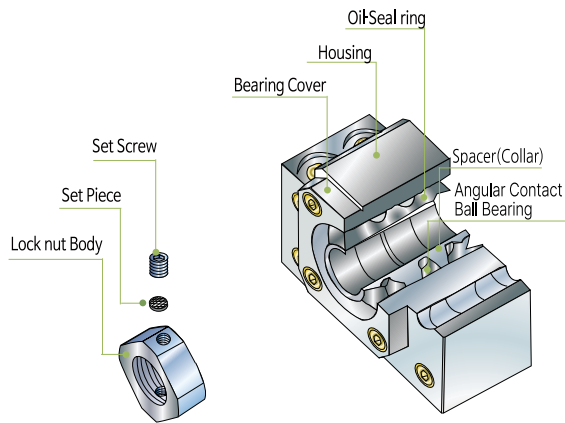

#### Fixed Side

- DF arrangement of angular contact ball bearing combinations
- Full range with high accuracy and without runout, achieved by applying an adequate preload in advance.
- Prevention of foreign material and leak of grease by the inner oil-seal rings
- Accompanied by high-accuracy lock-nut and collars (spacer).

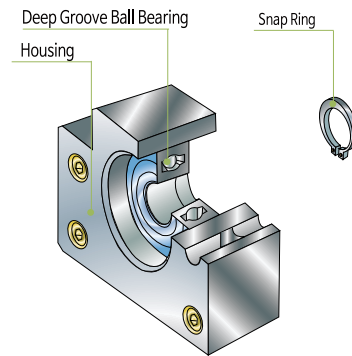

#### Supported Side

- Accompanied by a deep-groove ball bearing and a snap-ring

### Bearing Combinations

#### 1. Arrangement types of angular contact ball bearing combinations

- 1) DB combination (back to back): The large distance between the effective load centers results in higher rigidity at the moment load. However if accuracy of housing is not enough, it may produce damage e.g. flaking at a earlier stage due to the increased internal load. Preload is determined by torque when the user fastens the lock-nut.
- 2) DF combination (face to face): The small distance between effective load centers limits bearing capacity to sustain moment load, however it performs at a better level to absorb the margin of assembly error. Preload is determined at maker's assembly of bearing cover, thus this way allows easier self-management for users.

#### 2. Standard arrangement type of Sung-il products is DF combination.

※ In any case DB combination type is requested, please contact Sung-il Customer Service team for further assistance.

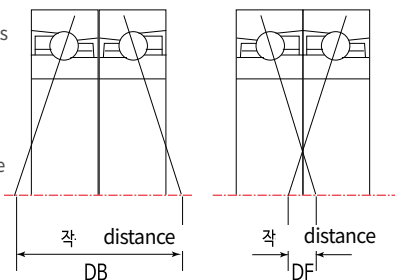

# SUPPORT UNIT

## SUPPORT UNIT FOR BALL SCREW (GENERAL LOAD)

### How to Order

#### Fixed Side

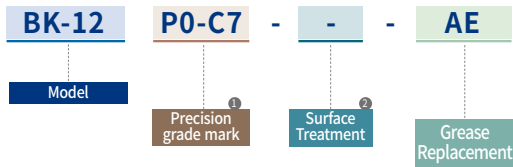

#### Supported Side

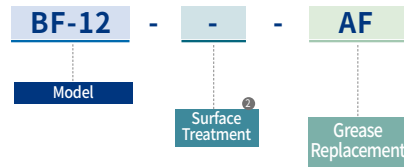

① Precision grade mark	Mark (Fixed Side Only)	Bearing precision grade	Preload
	P5	P5	Medium
	C8	General	Medium
	P0-C7	General	Light

② Surface Treatment	Mark	Surface Treatment
	no mark	Black Oxide
	RA	Low temperature Black Chrome Plating (Raydent)

Grease Model	Standard	LG2	AFE-CA	AFF	HT-Z1	NBU-15	XL-600
Mark	No mark	AG	AE	AF	AH	AN	AX

※ For detailed information regarding grease replacement, please refer to the guideline pages in the catalogue under the "Made-To-Order Process."

### Precautions for Supported-side Installation



On the top of the supported-side housing, there is marking for reference surface identification. Please install the product with reference to the polished surface in the direction indicated by the marking.

If assembled in the wrong direction, noise or vibration may occur due to misalignment of the bearing center or the bearing may not function smoothly. Therefore, please assemble with attention to the direction.

- Applicable models: AF, BF, CF, EF series (Rectangular shape)

# SUPPORT UNIT

## SUPPORT UNIT FOR BALL SCREW (GENERAL LOAD)

### List of Bearings (Fixed Side)

Bearing Inner dia. (mm)	Model					Bearing		
	EK	BK	AK	FK	CK	P5	C8	P0-C7
Ø4	EK-4			FK-4		AC-4-12-DF		634ZZ
Ø5	EK-5			FK-5		AC-5-14-DF		625ZZ
Ø6	EK-6			FK-6		706ATYNDFMP5	706ATYNDFC8	606ZZ
		BK-6						EN6
Ø8	EK-8			FK-8	CK-8	708ATYNDFMP5	708ATYNDFC8	EN8 / BA22-1
		BK-8						EN8 / BA22-1
			AK-8			708ATYNDFMP5		
Ø10	EK-10	BK-10	AK-10	FK-10	CK-10	7000ATYNDFMP5	7000AWDFM	7000AW
Ø12	EK-12	BK-12	AK-12	FK-12	CK-12	7001ATYNDFMP5	7001AWDFM	7001AW
Ø15	EK-15	BK-15	AK-15	FK-15	CK-15	7002ATYNDFMP5	7002AWDFM	7002AW
Ø17		BK-17		FK-17		7203ATYNDFMP5	7203AWDFM	7203AW
Ø20	EK-20		AK-20	FK-20		7204ATYNDFMP5	7204AWDFM	7204AW
		BK-20				7004ATYNDFMP5	7004AWDFM	7004AW
Ø25	EK-25	BK-25		FK-25		7205ATYNDFMP5	7205AWDFM	7205AW
Ø30		BK-30		FK-30		7206ATYNDFMP5	7206AWDFM	7206AW
Ø35		BK-35		FK-35		7207ATYNDFMP5	7207AWDFM	7207AW
Ø40		BK-40		FK-40		7208ATYNDFMP5	7208AWDFM	7208AW

※ The bearing brand may be subject to change with the same level products according to supplying conditions.

### List of Bearings (Supported Side)

Bearing Inner dia. (mm)	Model					Bearing
	EF	BF	AF	FF	CF	
Ø6	EF-6 / EF-8	BF-6 / BF-8	AF-8	FF-6 / FF-8	CF-8	606ZZ
Ø8	EF-10	BF-10	AF-10	FF-10		608ZZ
Ø10	EF-12	BF-12	AF-12	FF-12	CF-10/CF-12	6000ZZ
Ø15	EF-15	BF-15	AF-15	FF-15	CF-15	6002ZZ
Ø17		BF-17		FF-17		6203ZZ
Ø20	EF-20		AF-20	FF-20		6204ZZ
		BF-20				6004ZZ
Ø25	EF-25	BF-25		FF-25		6205ZZ
Ø30		BF-30		FF-30		6206ZZ
Ø35		BF-35		FF-35		6207ZZ
Ø40		BF-40		FF-40		6208ZZ

### Product Recommendation by Ball Screw Outer Diameters

Ball Screw Outer dia. (mm)	Fixed Side					Supported Side				
	EK	BK	AK	FK	CK	EF	BF	AF	FF	CF
Ø6	EK-4			FK-4						
Ø8	EK-5 / EK-6	BK-6		FK-5 / FK-6		EF-6	BF-6		FF-6	
Ø10, Ø12	EK-8	BK-8	AK-8	FK-8	CK-8	EF-8	BF-8	AF-8	FF-8	CF-8
Ø10, Ø12, Ø15	EK-10	BK-10	AK-10	FK-10	CK-10	EF-10	BF-10	AF-10	FF-10	CF-10
Ø14, Ø15, Ø16, Ø18	EK-12	BK-12	AK-12	FK-12	CK-12	EF-12	BF-12	AF-12	FF-12	CF-12
Ø20	EK-15	BK-15	AK-15	FK-15	CK-15	EF-15	BF-15	AF-15	FF-15	CF-15
		BK-17		FK-17			BF-17		FF-17	
Ø25, Ø28	EK-20	BK-20	AK-20	FK-20		EF-20	BF-20	AF-20	FF-20	
Ø30, Ø32, Ø36	EK-25	BK-25		FK-25		EF-25	BF-25		FF-25	
Ø40		BK-30		FK-30			BF-30		FF-30	
Ø45		BK-35		FK-35			BF-35		FF-35	
Ø50~Ø55		BK-40		FK-40			BF-40		FF-40	

# SUPPORT UNIT

## SUPPORT UNIT FOR BALL SCREW (GENERAL LOAD)

### Recommended Shape Of Ball Screw Shaft-End (Fixed Side)

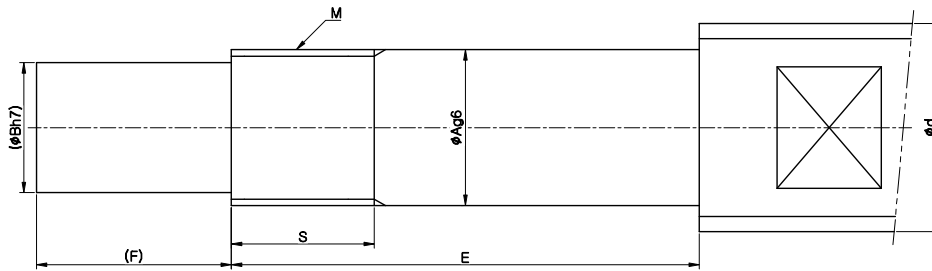

Dimensions(mm)																				Lock-nut									
d	A	B	EK				BK				AK				FK				CK				Model	Size (MxPitch)					
			Model	E	F	S	Model	E	F	S	Model	E	F	S	Model	E	F	S	Model	E	F	S							
Ø6	4	3	EK-4	23	5	8												FK-4	23	5	8							RN-4	M4×0.5
Ø8	5	4	EK-5	25	6	8												FK-5	25	6	8							RN-5	M5×0.5
	6	4	EK-6	30	8	8	BK-6	30	8	8								FK-6	30	8	8							RN-6	M6×0.75
Ø10 - Ø12	8	6	EK-8	35	9	10	BK-8	35	9	10	AK-8	30	9	10	FK-8	35	9	10	CK-8	34	9	10						RN-8	M8×1 / 0.75
Ø10 - Ø15	10	8	EK-10	36	15	11	BK-10	39	15	16	AK-10	36	15	11	FK-10	36	15	11	CK-10	36	15	11						RN-10	M10×1 / 0.75
Ø14 - Ø18	12	10	EK-12	36	15	11	BK-12	39	15	14	AK-12	36	15	11	FK-12	36	15	11	CK-12	36	15	11						RN-12	M12×1
Ø20	15	12	EK-15	49	20	13	BK-15	40	20	12	AK-15	49	20	13	FK-15	49	20	13	CK-15	49	20	13						RN-15	M15×1
Ø25 - Ø28	17	15					BK-17	53	23	17					FK-17	57	23	17										RN-17	M17×1
	20	17	EK-20	64	25	17	BK-20	53	25	16	AK-20	64	25	17	FK-20	64	25	17										RN-20	M20×1
Ø30 - Ø36	25	20	EK-25	76	30	22	BK-25	65	30	19					FK-25	76	30	20										RN-25	M25×1.5
Ø40	30	25					BK-30	72	38	25					FK-30	72	38	25										RN-30	M30×1.5
Ø45	35	30					BK-35	83	45	28					FK-35	83	45	28										RN-35	M35×1.5
Ø50 - Ø55	40	35					BK-40	98	50	35					FK-40	98	50	35										RN-40	M40×1.5

# SUPPORT UNIT

## SUPPORT UNIT FOR BALL SCREW (GENERAL LOAD)

### Recommended Shape Of Ball Screw Shaft-End (Supported Side)

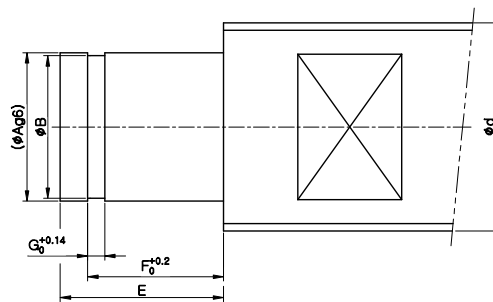

Dimensions(mm)

d	EF	BF	AF	FF	CF	A	E	B	F	G
Ø8	EF-6	BF-6		FF-6		6	9	5.6	6.9	0.9
Ø10 - Ø12	EF-8	BF-8	AF-8	FF-8	CF-8	6	9	5.6	6.9	0.9
Ø10 - Ø15	EF-10	BF-10	AF-10	FF-10		8	10	7.6	7.9	0.9
Ø14 - Ø18	EF-12	BF-12	AF-12	FF-12	CF-12	10	11	9.6	9.15	1.15
Ø20	EF-15	BF-15	AF-15	FF-15	CF-15	15	13	14.3	10.15	1.15
Ø25 - Ø28		BF-17		FF-17		17	16	16.2	13.15	1.15
	EF-20	BF-20	AF-20	FF-20		20	19(16)	19	15.35(13.35)	1.35
Ø30 - Ø36	EF-25	BF-25		FF-25		25	20	23.9	16.35	1.35
Ø40		BF-30		FF-30		30	21	28.6	17.75	1.75
Ø45		BF-35		FF-35		35	22	33	18.75	1.75
Ø50 - Ø55		BF-40		FF-40		40	23	38	19.95	1.95

※ The values in brackets are for model no. BF-20.

# SUPPORT UNIT : EK SERIES



## SUPPORT UNIT FOR BALL SCREW (GENERAL LOAD)

### EK-4 ~ EK-5

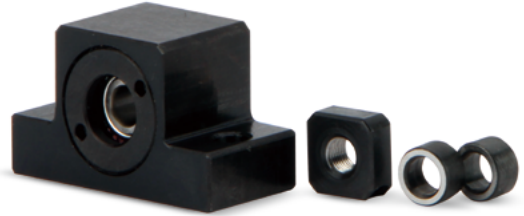
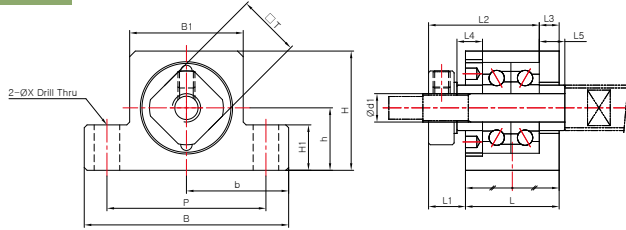

### EK-6 ~ EK-8

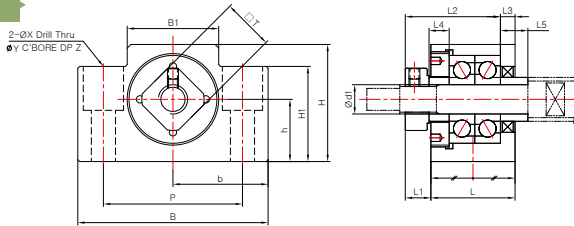

### EK-10 ~ EK-25

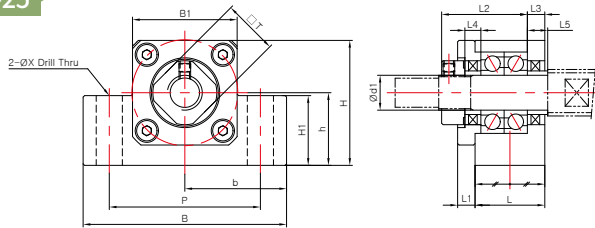

### Additional note for [EK-25]

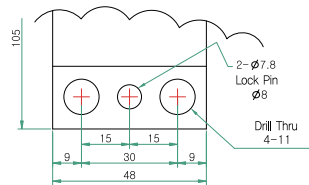

### Dimensions

Model	Sizes (mm)																	Mass (g)	
	Body															Spacer(collar)			
	d1	L	L1	L2	L3	B	H	b±0.02	h±0.02	B1	H1	P	X	Y	Z	□	L4		L5
EK-4 P5 / P0-C7	4	15	5.5	17.5 / 18.5	3 / 2	34	19	17	10	18	7	26	4.5	-	-	10	4.5 / 3.5	4.5 / 3.5	50
EK-5 P5 / P0-C7	5	16.5	5.5 / 6.5	19.5	3.5	36	21	18	11	20	8	28	4.5	-	-	11	5.5 / 4.5	5.5 / 4.5	68
EK-6	6	20	5.5	22	3.5	42	25	21	13	18	20	30	5.5	9.5	11	12	5	7	120
EK-8	8	23	7	26	4	52	32	26	17	25	26	38	6.6	11	12	14	5.5	7.5	230
EK-10	10	24	6	29.5	6	70	43	35	25	36	24	52	9	-	-	16	5.5	5.5	430
EK-12	12	24	6	29.5	6	70	43	35	25	36	24	52	9	-	-	19	5.5	5.5	420
EK-15	15	25	6	36	5	80	50	40	30	41	25	60	11	-	-	22	10	10	530
EK-20	20	42	10	50	10	95	58	47.5	30	56	25	75	11	-	-	30	11	11	1,310
EK-25	25	48	13	59	14	105	68	52.5	35	66	25	85	<See the additional note above>			35	14	14	1,950

※ Only EK-4 and EK-5 have different dimensions according to the bearing grade (P5/P0-C7).

## SUPPORT UNIT : EF SERIES



## SUPPORT UNIT FOR BALL SCREW (GENERAL LOAD)

## EF-6 ~ EF-8

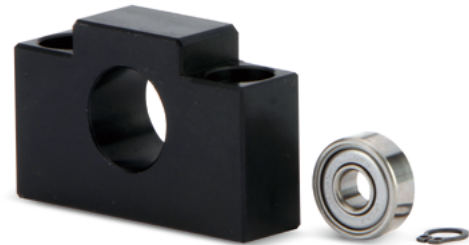
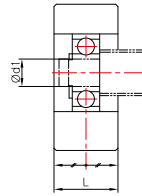
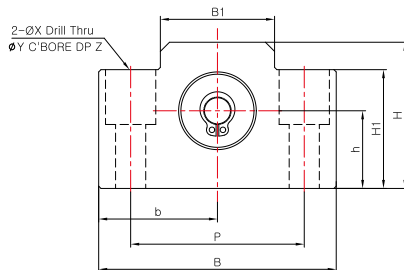

## EF-10 ~ EF-25

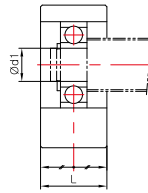
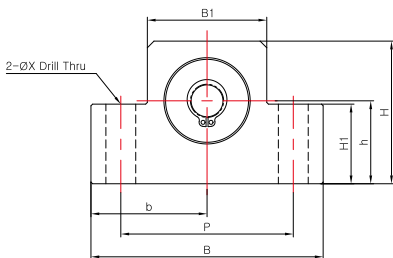

## Dimensions

Model	Sizes (mm)												Mass (g)	Snap-ring	Bearing
	Body														
	d1	L	B	H	b±0.02	h±0.02	B1	H1	P	X	Y	Z			
EF-6	6	12	42	25	21	13	18	20	30	5.5	9.5	11	60	C6	606ZZ
EF-8	6	14	52	32	26	17	25	26	38	6.6	11	12	120	C6	606ZZ
EF-10	8	20	70	43	35	25	36	24	52	9	-	-	300	C8	608ZZ
EF-12	10	20	70	43	35	25	36	24	52	9	-	-	280	C10	6000ZZ
EF-15	15	20	80	50	40	30	41	25	60	9	-	-	320	C15	6002ZZ
EF-20	20	26	95	58	47.5	30	56	25	75	11	-	-	570	C20	6204ZZ
EF-25	25	30	105	68	52.5	35	66	25	85	11	-	-	880	C25	6205ZZ

# SUPPORT UNIT : BK SERIES



## SUPPORT UNIT FOR BALL SCREW (GENERAL LOAD)

### BK-6 ~ BK-8

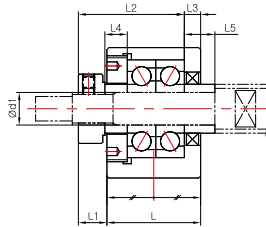
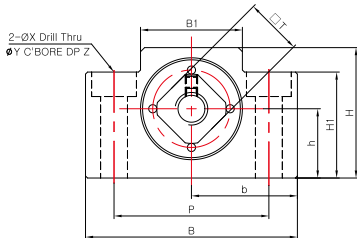

### BK-10 ~ BK-40

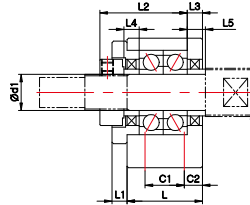
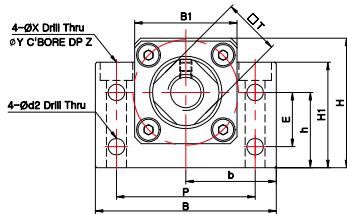

### Dimensions

Model	Sizes (mm)																							Mass (g)
	Body																				Spacer(collar)			
	d1	L	L1	L2	L3	B	H	b±0.02	h±0.02	B1	H1	E	P	C1	C2	d2	X	Y	Z	□T	L4	L5		
BK-6	6	23	5	24	4	52	32	26	17	25	26	-	38	-	-	-	6.6	11	6	12	5	5	230	
BK-8	8	23	7	26	4	52	32	26	17	25	26	-	38	-	-	-	6.6	11	6	14	5.5	7.5	230	
BK-10	10	25	5	29	5	60	39	30	22	34	32.5	15	46	13	6	5.5	6.6	10.8	5	16	5	5	360	
BK-12	12	25	5	29	5	60	43	30	25	34	35	18	46	13	6	5.5	6.6	10.8	6	19	5	5	390	
BK-15	15	27	6	32	6	70	48	35	28	40	38	18	54	15	6	5.5	6.6	11	6	22	6	6	530	
BK-17	17	35	9	44	7	86	64	43	39	50	55	28	68	19	8	6.6	9	14	8.5	24	7	7	1,270	
BK-20	20	35	8	43	8	88	60	44	34	52	50	22	70	19	8	6.6	9	14	8.5	30	8	8	1,650	
BK-25	25	42	12	54	9	106	80	53	48	64	70	33	85	22	10	9	11	17.5	11	35	9	9	2,310	
BK-30	30	45	14	61	9	128	89	64	51	76	78	33	102	23	11	11	14	20	13	40	9	9	3,330	
BK-35	35	50	14	67	12	140	96	70	52	88	79	35	114	26	12	11	14	20	13	50	12	12	4,380	
BK-40	40	61	18	76	15	160	110	80	60	100	90	37	130	33	14	14	18	26	17.5	50	15	15	6,670	

## SUPPORT UNIT : BF SERIES



## SUPPORT UNIT FOR BALL SCREW (GENERAL LOAD)

## BF-6 ~ BF-8

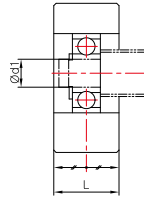
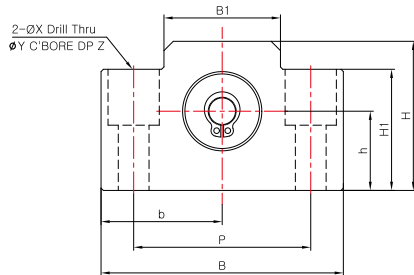

## BF-10 ~ BF-40

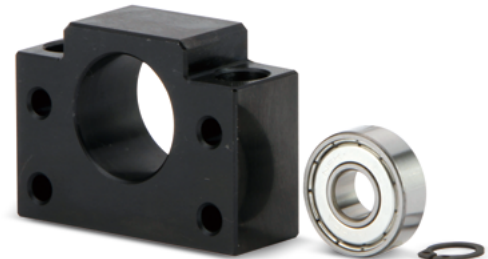
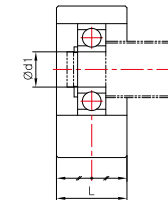
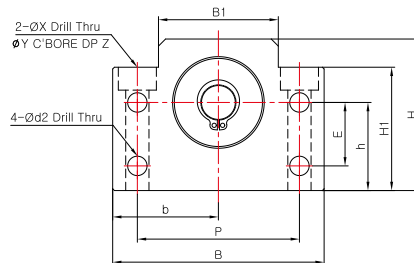

## Dimensions

Model	Sizes (mm)														Mass (g)	Snap-ring	Bearing
	Body																
	d1	L	B	H	b±0.02	h±0.02	B1	H1	E	P	d2	X	Y	Z			
BF-6 / BF-8	6	14	52	32	26	17	25	26	-	38	-	6.6	11	12	120	C6	606ZZ
BF-10	8	20	60	39	30	22	34	32.5	15	46	5.5	6.6	10.8	5	260	C8	608ZZ
BF-12	10	20	60	43	30	25	34	35	18	46	5.5	6.6	10.8	6.5	270	C10	6000ZZ
BF-15	15	20	70	48	35	28	40	38	18	54	5.5	6.6	11	6.5	310	C15	6002ZZ
BF-17	17	23	86	64	43	39	50	55	28	68	6.6	9	14	8.5	680	C17	6203ZZ
BF-20	20	26	88	60	44	34	52	50	22	70	6.6	9	14	8.5	710	C20	6004ZZ
BF-25	25	30	106	80	53	48	64	70	33	85	9	11	17.5	11	1340	C25	6205ZZ
BF-30	30	32	128	89	64	51	76	78	33	102	11	14	20	13	1880	C30	6206ZZ
BF-35	35	32	140	96	70	52	88	79	35	114	11	14	20	13	2080	C35	6207ZZ
BF-40	40	37	160	110	80	60	100	90	37	130	14	18	26	17.5	3100	C40	6208ZZ

# SUPPORT UNIT : AK/AF SERIES



## SUPPORT UNIT FOR BALL SCREW (GENERAL LOAD)

### AK-8 ~ AK-20

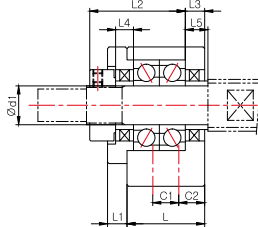
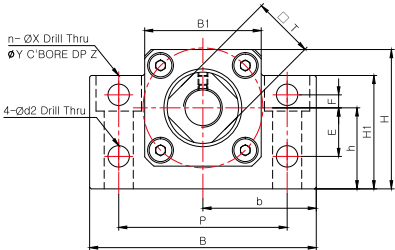

### Dimensions

Model	Sizes (mm)																							Mass (g)	
	Body																				Spacer(collar)				
	d1	L	L1	L2	L3	B	H	b±0.02	h±0.02	B1	H1	E	F	P	C1	C2	d2	n	X	Y	Z	□T	L4		L5
AK-8	8	20	3	24.5	4	52	32	26	17	25	26	10	4	38	-	10	5.5	2	6.6	11	12	14	4	4	190
AK-10	10	24	6	29.5	6	70	43	35	25	36	35	15	4	52	-	12	6.6	2	9	14	11	16	5.5	5.5	450
AK-12	12	24	6	29.5	6	70	43	35	25	36	35	15	4	52	-	12	6.6	2	9	14	11	19	5.5	5.5	440
AK-15	15	25	6	36	5	80	50	40	30	41	40	15	4	60	-	12.5	6.6	2	11	17	15	22	10	10	570
AK-20	20	42	10	50	10	95	58	47.5	30	56	45	-	-	75	22	10	-	4	11	17	15	30	11	11	1,400

### AF-8 ~ AF-20

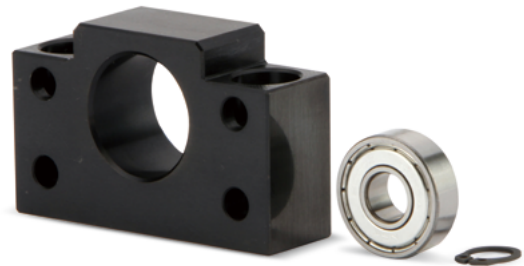
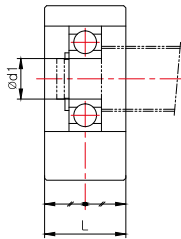
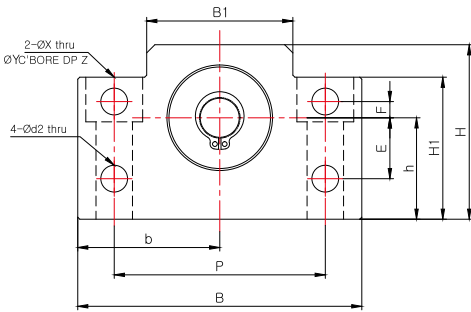

### Dimensions

Model	Sizes (mm)															Mass (g)	Snap-ring	Bearing
	Body																	
	d1	L	B	H	b±0.02	h±0.02	B1	H1	E	F	P	d2	X	Y	Z			
AF-8	6	15	52	32	26	17	25	26	10	4	38	5.5	6.6	11	12	130	C6	606ZZ
AF-10	8	20	70	43	35	25	36	35	15	4	52	6.6	9	14	11	320	C8	608ZZ
AF-12	10	20	70	43	35	25	36	35	15	4	52	6.6	9	14	11	330	C10	6000ZZ
AF-15	15	20	80	50	40	30	41	40	15	4	60	6.6	9	14	11	370	C15	6002ZZ
AF-20	20	26	95	58	47.5	30	56	45	-	-	75	-	11	17	15	660	C20	6204ZZ

# SUPPORT UNIT : FK SERIES



## SUPPORT UNIT FOR BALL SCREW (GENERAL LOAD)

### FK-4 ~ FK-8

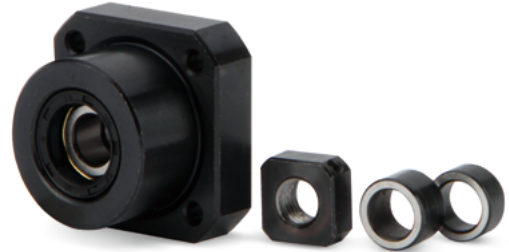
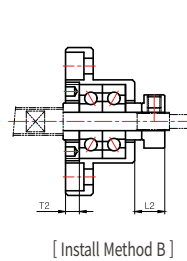
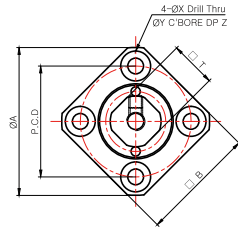
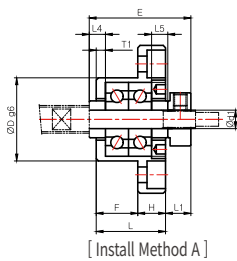

### FK-10 ~ FK-30

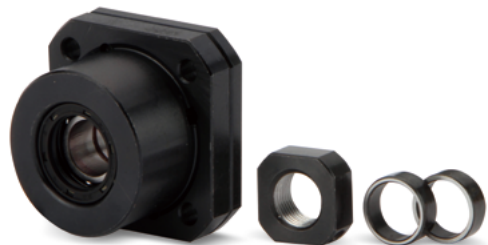
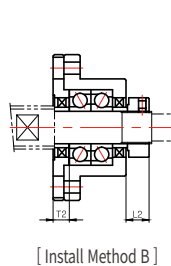
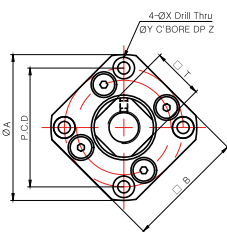
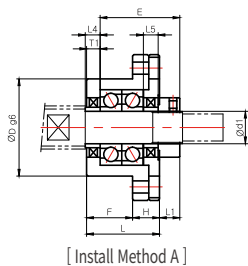

※ **Additional note for [FK-30]**

In case of choosing "Install Method B", size of spacer(collar) needs to be accordingly changed. Please contact Sung-il Customer Service team for more details.

## Dimensions

Model	Sizes (mm)																		Mass (g)	
	Body																Spacer(collar)			
	d1	L	H	F	E	D	A	P.C.D	□B	Install Method A		Install Method B		X	Y	Z	□T	L4		L5
									L1	T1	L2	T2								
FK-4 P5 / P0-C7	4	15	6	9	22	18	32	24	25	5.5	3/2	6.5	4/3	3.4	6	4	10	4.5/3.5	4.5/3.5	40
FK-5 P5 / P0-C7	5	16.5	6	10.5	24	20	34	26	26	5.5/6.5	3.5	7/6	5/3	3.4	6/6.5	4	11	5.5/4.5	5.5/4.5	50
FK-6	6	20	7	13	29	22	36	28	28	5.5	3.5	8.5	4.5	3.4	6.5	4	12	7	5	65
FK-8	8	23	9	14	33.5	28	43	35	35	7	4	10	5	3.4	6.5	4	14	7.5	5.5	125
FK-10	10	27	10	17	29.5	34	52	42	42	7.5	5	8.5	6	4.5	8	4	16	5.5	5.5	200
FK-12	12	27	10	17	29.5	36	54	44	44	7.5	5	8.5	6	4.5	8	4	19	5.5	5.5	225
FK-15	15	32	15	17	36	40	63	50	52	10	6	12	8	5.5	9.5	6	22	10	10	340
FK-17	17	45	22	23	46	50	77	62	61	10	9	13	12	6.6	11	10	24	9	9	770
FK-20	20	52	22	30	50	57	85	70	68	8	10	12	14	6.6	11	10	30	11	11	1,065
FK-25	25	57	27	30	60	63	98	80	79	13	10	20	17	9	15	13	35	15	15	1,465
FK-30	30	62	30	32	61	75	117	95	93	11	12	21	18	11	17.5	15	40	9	9	2,300

※ Only FK-4 and FK-5 have different dimensions according to the bearing grade (P5/P0-C7).

# SUPPORT UNIT : FK SERIES



## SUPPORT UNIT FOR BALL SCREW (GENERAL LOAD)

### FK-25D, FK-30D

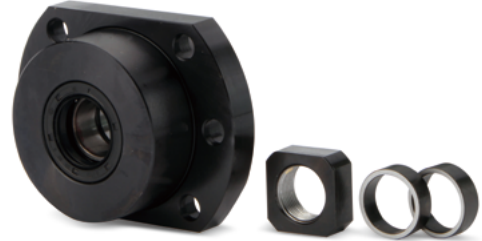
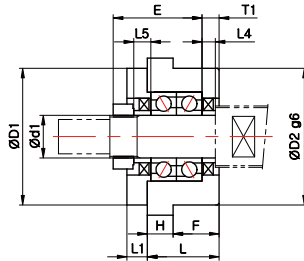
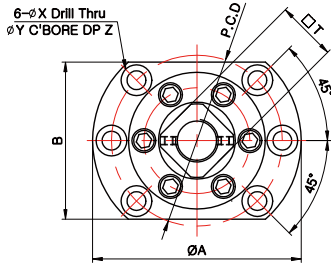

### FK-35, FK-40

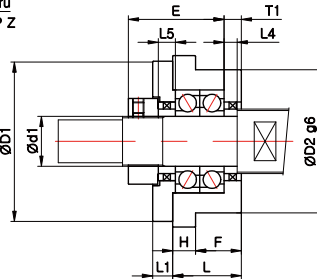
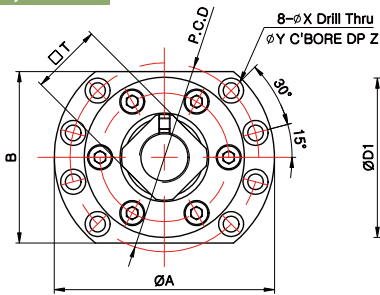

### Dimensions

Model	Sizes (mm)																		Mass (g)
	Body																Spacer(collar)		
	d1	L	H	F	E	D1	D2	A	P.C.D	B	L1	T1	X	Y	Z	□T	L4	L5	
FK-25D	25	42	15	27	52	80	80	122	100	92	12	10	11	18	11	35	10	10	2,500
FK-30D	30	45	15	30	59	96	90	138	116	106	14	11	11	18	11	40	11	11	3,500
FK-35	35	48	16	32	67	112	100	154	132	120	14	12	11	17.5	11	50	12	12	4,080
FK-40	40	61	18	43	76	126	120	176	150	128	18	16	14	20	13	50	15	15	6,750

# SUPPORT UNIT : FF SERIES



## SUPPORT UNIT FOR BALL SCREW (GENERAL LOAD)

### FF-6 ~ FF-30

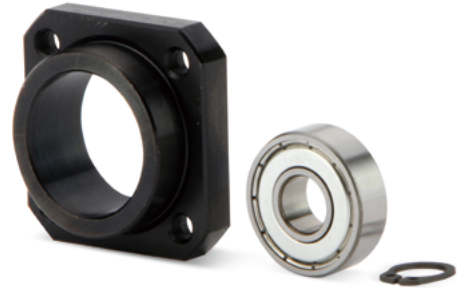
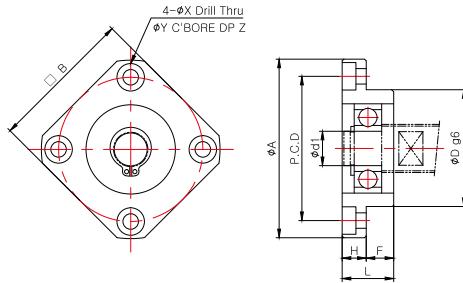

### Dimensions

Model	Sizes (mm)											Mass (g)	Snap-ring	Bearing
	Body													
	d1	L	H	F	D	A	P.C.D	□B	X	Y	Z			
FF-6 / FF-8	6	10	6	4	22	36	28	28	3.4	6.5	3	30	C6	606ZZ
FF-10	8	12	7	5	28	43	35	35	3.4	6.5	4	60	C8	608ZZ
FF-12	10	15	7	8	34	52	42	42	4.5	8	4	100	C10	6000ZZ
FF-15	15	17	9	8	40	63	50	52	5.5	9.5	5.5	140	C15	6002ZZ
FF-17	17	20	11	9	50	77	62	61	6.6	11	6.5	290	C17	6203ZZ
FF-20	20	20	11	9	57	85	70	68	6.6	11	6.5	380	C20	6204ZZ
FF-25	25	24	14	10	63	98	80	79	9	14	8.5	590	C25	6205ZZ
FF-30	30	27	18	9	75	117	95	93	11	17.5	11	930	C30	6206ZZ

### FF-25D, FF-30D

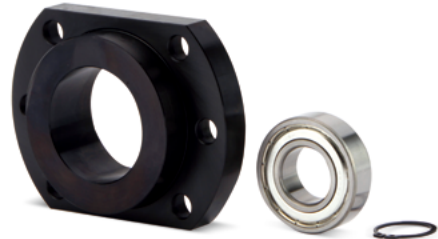
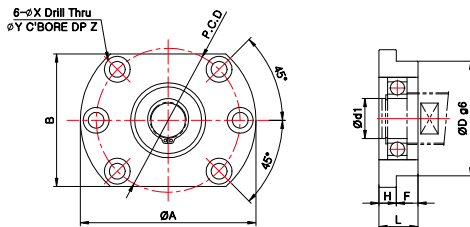

### FF-35, FF-40

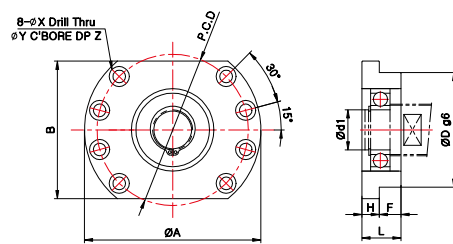

### Dimensions

Model	Sizes (mm)											Mass (g)	Snap-ring	Bearing
	Body													
	d1	L	H	F	D	A	P.C.D	□B	X	Y	Z			
FF-25D	25	30	15	15	80	122	100	92	11	18	11	1,400	C25	6205ZZ
FF-30D	30	32	15	17	90	138	116	106	11	18	11	1,800	C30	6206ZZ
FF-35	35	34	15	19	100	154	132	120	11	17.5	11	2,050	C35	6207ZZ
FF-40	40	36	18	18	120	176	150	128	14	20	13	3,050	C40	6208ZZ

# SUPPORT UNIT : CK/CF SERIES (Low-Centered Type)



## SUPPORT UNIT FOR BALL SCREW (GENERAL LOAD)

### CK-8 ~ CK-15

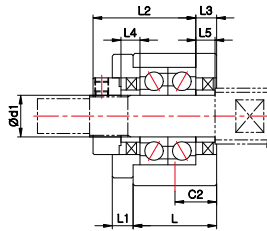
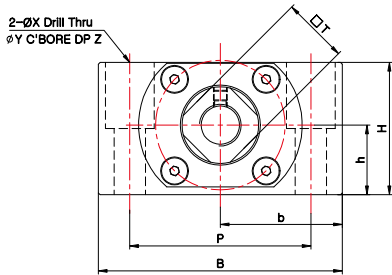

### Dimensions

Model	Sizes (mm)																Mass (g)	
	Body													Spacer(collar)				
	d1	L	L1	L2	L3	B	H	b±0.02	h±0.02	P	C2	X	Y	Z	□T	L4		L5
CK-8	8	21.5	4	26.5	3.5	62	31	31	15.5	46	11	9	14	18	14	6	6	260
CK-10	10	24	6	29.5	6	70	38	35	20	52	12	9	14	19	16	5.5	5.5	430
CK-12	12	24	6	29.5	6	70	38	35	20	52	12	9	14	19	19	5.5	5.5	430
CK-15	15	25	6	38	5	80	42	40	22	60	12.5	11	17	23	22	10	10	540

### CF-8 ~ CF-15

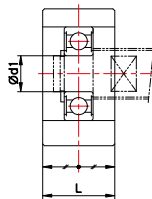
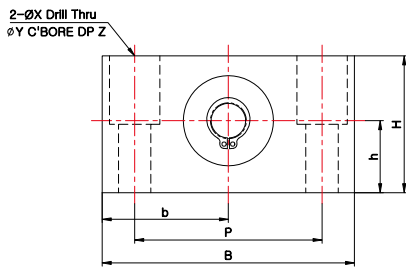

### Dimensions

Model	Sizes (mm)											Mass (g)	Snap-ring	Bearing
	Body													
	d1	L	B	H	b±0.02	h±0.02	P	X	Y	Z				
CF-8	6	16	62	31	31	15.5	46	9	14	18	165	C6	606ZZ	
CF-10	10	20	70	38	35	20	52	9	14	19	285	C10	6000ZZ	
CF-12	10	20	70	38	35	20	52	9	14	19	285	C10	6000ZZ	
CF-15	15	20	80	42	40	22	60	9	14	23	355	C15	6002ZZ	

# SUPPORT UNIT : WBK SERIES (Miniature Type)



## SUPPORT UNIT FOR BALL SCREW (GENERAL LOAD)

WBK-04, WBK-06

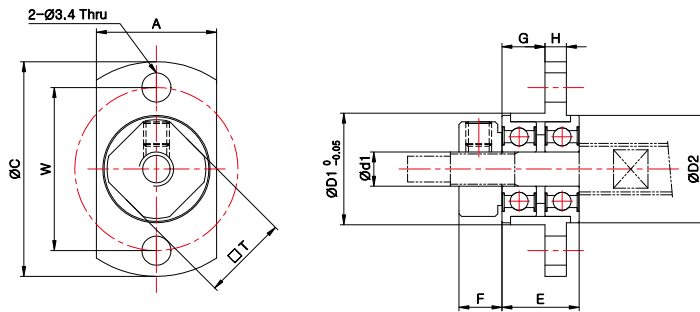

- ※ Make sure the lock-nut is fastened fully due to frequent detachment of flange shaped miniature ball bearing.
- ※ Spacer(collar) are mounted on the body at release for the loss prevention.

### Dimensions

Model	Sizes (mm)												
	Body											Lock-nut	Spacer(collar)
	d1	A	C	D1	D2	E	F	G	H	W	T	M	
WBK-04	4	14	25	13	12.5	9	5	5	2.5	19	10	M4×0.5	Ø8×Ø4×0.9 - 1EA
WBK-06	6	19	30	18	17	11	5	6.8	2.5	24	12	M6×0.75	Ø9.1×Ø6×0.9 - 1EA

# SUPPORT UNIT

## SUPPORT UNIT FOR BALL SCREW (HIGH LOAD) : SWBK SERIES

### Support Unit For Ball Screw (High Load) : SWBK Series

#### Structure

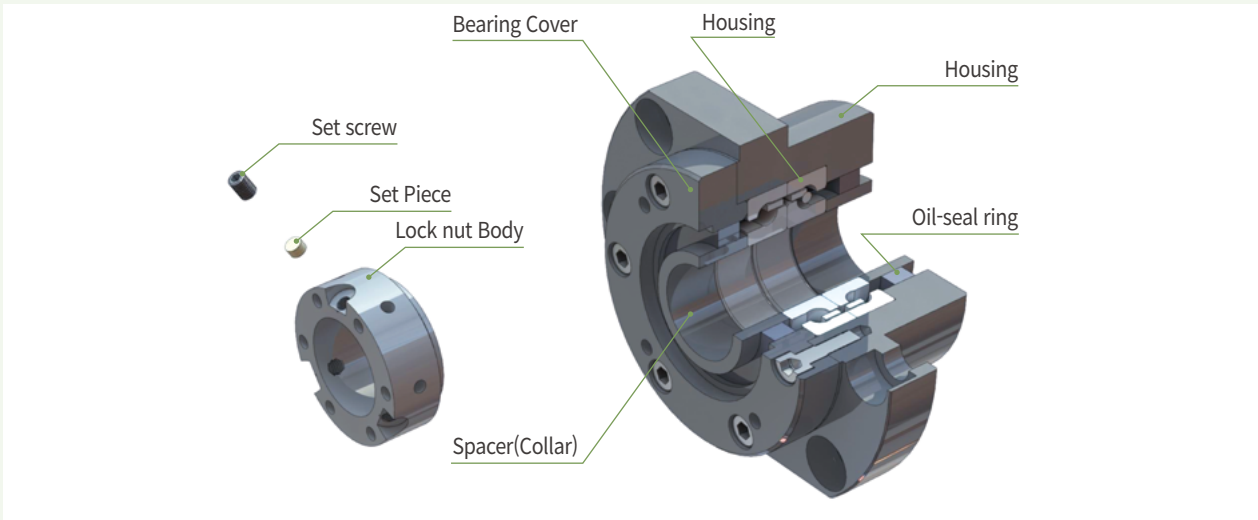

#### Bearing Combinations

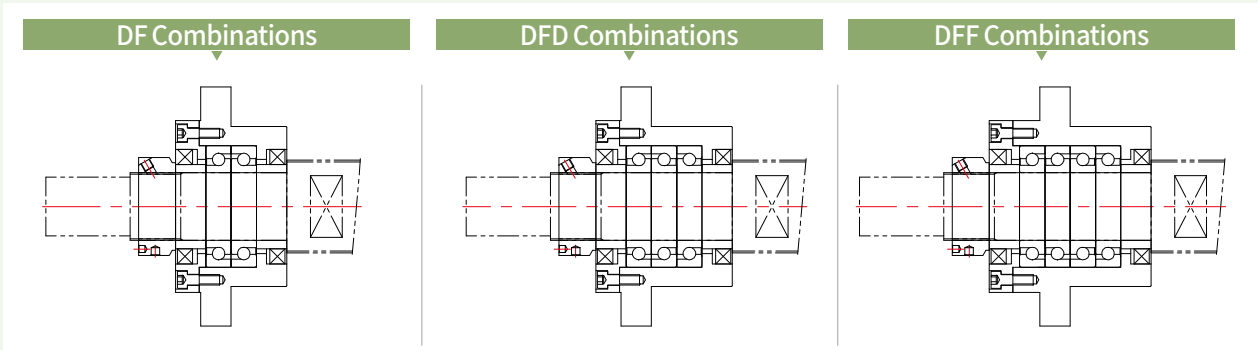

#### How to Order

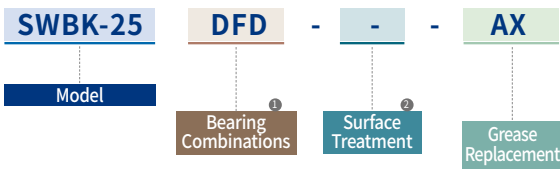

① Bearing Combinations	Mark	Combinations	② Surface Treatment	Mark	Surface Treatment
	DF	Double-row		no mark	Black Oxide
	DFD	Triple-row		RA	Low temperature Black Chrome Plating (Raydent)
	DFF	Four-row			

Grease Model	Standard	LG2	AFE-CA	AFF	HT-Z1	NBU-15	XL-600
Mark	No mark	AG	AE	AF	AH	AN	AX

※ For detailed information regarding grease replacement, please refer to the guideline pages in the catalogue under the "Made-To-Order Process."

# SUPPORT UNIT

## SUPPORT UNIT FOR BALL SCREW (HIGH LOAD) : HBK SERIES

### Support Unit For Ball Screw (High Load) : HBK Series

#### Features

- This product can accommodate higher loads compared to the SWBK series.
- Preload is determined by the fastening torque of the locknut; therefore, be sure to follow the recommended fastening torque.
- Supplied as standard with a grease injection type.
- The product comes with a locknut included.

#### Structure

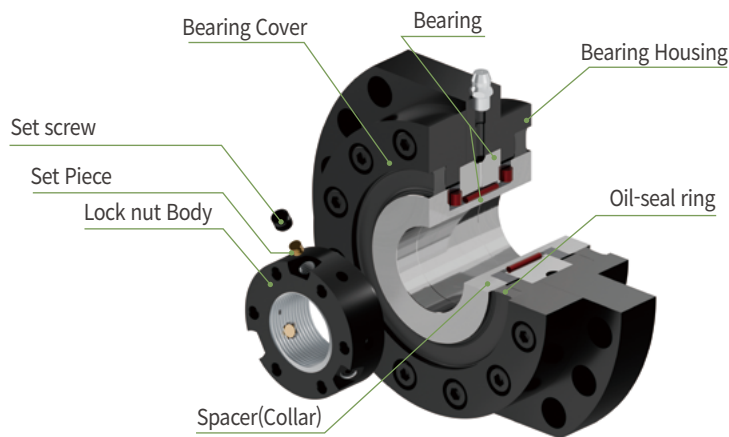

#### Bearing Structure

- The wide contact surface of the cylindrical rollers supports both radial loads and partial axial loads, ensuring structural rigidity.
- The cage precisely keeps the rollers evenly spaced. This reduces friction, heat generation, and noise, enabling stable rotation even under high-load and high-torque conditions.
- The bearing is designed for direct grease injection, allowing long-term stable lubrication.

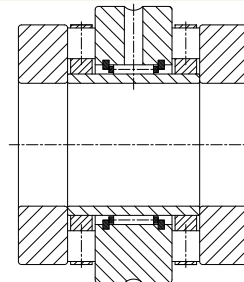

#### How to Order

		<b>HBK-30</b>		<b>RA</b>	-	<b>AG</b>		
		Model		Surface Treatment		Grease Replacement		
①Surface Treatment	Mark				Surface Treatment			
		no mark				Black Oxide		
		RA				Low temperature Black Chrome Plating (Raydent)		
Grease Model	Standard	LG2	AFC-CA	AFF	HT-Z1	NBU-15	XL-600	
Mark	No mark	AG	AE	AF	AH	AN	AX	

※ For detailed information regarding grease replacement, please refer to the guideline pages in the catalogue under the "Made-To-Order Process."

# SUPPORT UNIT

## SUPPORT UNIT FOR BALL SCREW (HIGH LOAD)

### Support Unit For Ball Screw (High Load) – Specification

#### SWBK Series

Model	Bearing Combinations	Bearing	Basic Dynamic Load Rating (N)	Limiting Static Axial Load (N)	Permissible Axial Load (N)	Preload (N)	Axial Rigidity (N/μm)	Starting Torque (N·cm)
SWBK-17	DF	17TAC 47C	23,000	26,600	18,600	1,450	630	14
SWBK-17	DFD	17TAC 47C	37,500	53,000	37,100	1,970	930	19
SWBK-20	DF	20TAC 47C	23,000	26,600	18,600	1,450	630	14
SWBK-20	DFD	20TAC 47C	37,500	53,000	37,100	1,970	930	19
SWBK-25	DF	25TAC 62C	29,900	40,500	28,400	2,280	850	21
SWBK-25	DFD	25TAC 62C	48,500	81,500	57,100	3,100	1,250	28
SWBK-30	DF	30TAC 62C	30,500	43,000	30,100	2,400	890	23
SWBK-30	DFD	30TAC 62C	50,000	86,000	60,200	3,260	1,310	30
SWBK-35	DF	35TAC 72C	32,500	50,000	35,000	2,750	1,030	27
SWBK-35	DFD	35TAC 72C	53,000	100,000	70,000	3,740	1,500	34
SWBK-35	DFF	35TAC 72C	53,000	100,000	70,000	5,490	2,060	43
SWBK-40	DF	40TAC 72C	33,500	52,000	36,400	2,860	1,080	28
SWBK-40	DFD	40TAC 72C	54,000	104,000	72,800	3,900	1,590	36
SWBK-40	DFF	40TAC 72C	54,000	104,000	72,800	5,730	2,150	46
SWBK-50	DF	50TAC 100C	66,000	72,800	51,000	4,650	1,410	42
SWBK-50	DFD	50TAC 100C	107,000	145,600	101,900	6,320	2,100	57
SWBK-50	DFF	50TAC 100C	107,000	145,600	101,900	9,120	2,820	82

※ The bearing brand may be subject to change with the same level products according to supplying conditions.

#### HBK Series

Model	Basic Load(Axial) (N)		Basic Load(Radial) (N)		Axial Rigidity (N/μm)	Max. rpm (min <sup>-1</sup> )	Max. Starting Torque (N·cm)	Recommended Fastening Torque (N·cm)
	Dynamic	Static	Dynamic	Static				
HBK-30	90,400	216,200	18,100	32,900	3,100	1,300	140	75.4
HBK-40	101,800	266,100	26,000	56,500	3,800	1,200	180	104.7
HBK-50	163,000	453,000	35,600	64,400	5,300	1,100	360	178.5

# SUPPORT UNIT

## SUPPORT UNIT FOR BALL SCREW (HIGH LOAD)

### Recommended Shape Of Ball Screw Shaft-End (Fixed Side)

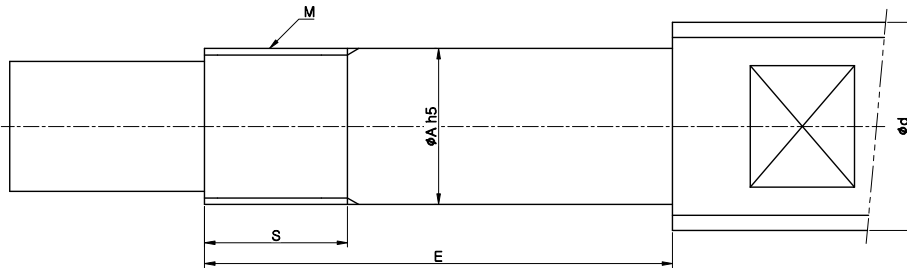

d	Dimensions(mm)				Lock-nut		
	A	Model	E	S	Model	Size M x pitch	
Ø25 - Ø28	17	SWBK-17	DF	81	23	HLRN-17	M17×1.0
			DFD	96			
	20	SWBK-20	DF	81	23	HLRN-20	M20×1.0
			DFD	96			
Ø30 - Ø36	25	SWBK-25	DF	89	26	HLRN-25	M25×1.5
			DFD	104			
Ø40	30	SWBK-30	DF	89	26	HLRN-30	M30×1.5
			DFD	104			
		HBK-30	89	26			
Ø45	35	SWBK-35	DF	90	28	HLRN-35	M35×1.5
			DFD	105			
			DFD	120			
Ø50 - Ø55	40	SWBK-40	DF	92	30	HLRN-40	M40×1.5
			DFD	107			
			DFD	122			
		HBK-40	101	30			
Ø63 - Ø70	50	SWBK-50	DF	117	34	HLRN-50	M50×1.5
			DFD	137			
			DFD	157			
		HBK-50	111	34			

# SUPPORT UNIT : SWBK SERIES



## SUPPORT UNIT FOR BALL SCREW (HIGH LOAD)

SWBK-17~SWBK-30

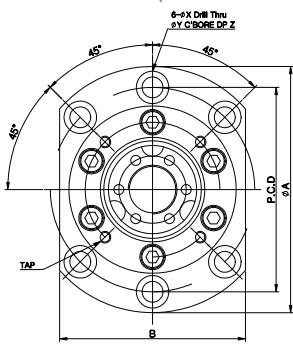

SWBK-35, SWBK-40

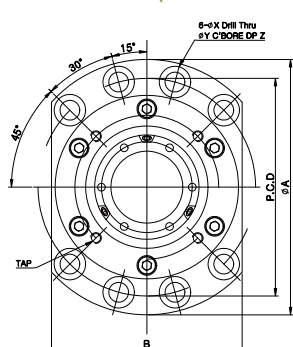

SWBK-50

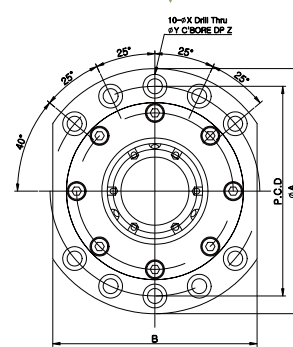

	SWBK-17,SWBK-20	SWBK-25,SWBK-30	SWBK-35,SWBK-40	SWBK-50
TAP	4-M5 TAP DP10	4-M6 TAP DP12	4-M6 TAP DP12	-
PCD	58	70	80	-

DF Combinations

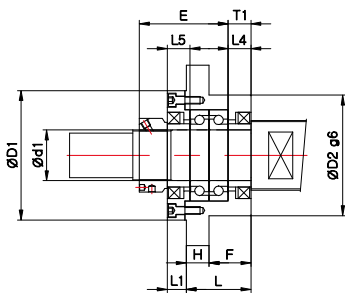

DFD Combinations

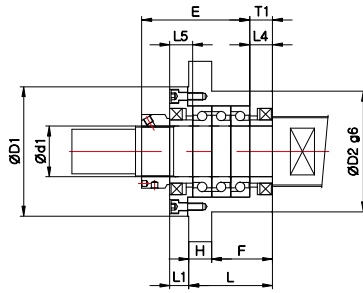

DFF Combinations

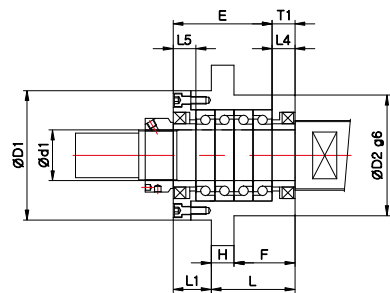

### Dimensions

Model	Sizes (mm)																	Mass (g)
	Body															Spacer(collar)		
	d1	L	H	F	E	T1	D1	D2	A	P.C.D	B	L1	X	Y	Z	L4	L5	
SWBK-17-DF	17	47	15	32	63	15	72	70	106	88	80	13	9	14	8.5	15	15	1,900
SWBK-17-DFD	17	62	15	47	78	15	72	70	106	88	80	13	9	14	8.5	15	15	2,300
SWBK-20-DF	20	47	15	32	63	15	72	70	106	88	80	13	9	14	8.5	15	15	1,900
SWBK-20-DFD	20	62	15	47	78	15	72	70	106	88	80	13	9	14	8.5	15	15	2,250
SWBK-25-DF	25	51	18	33	68	18	90	85	130	110	100	15	11	17.5	11	18	18	3,100
SWBK-25-DFD	25	66	18	48	83	18	90	85	130	110	100	15	11	17.5	11	18	18	3,400
SWBK-30-DF	30	51	18	33	68	18	90	85	130	110	100	15	11	17.5	11	18	18	3,000
SWBK-30-DFD	30	66	18	48	83	18	90	85	130	110	100	15	11	17.5	11	18	18	3,300
SWBK-35-DF	35	51	18	33	68	18	102	95	142	121	106	15	11	17.5	11	18	18	3,400
SWBK-35-DFD	35	66	18	48	83	18	102	95	142	121	106	15	11	17.5	11	18	18	4,300
SWBK-35-DFF	35	66	18	48	98	18	102	95	142	121	106	30	11	17.5	11	18	18	5,000
SWBK-40-DF	40	51	18	33	70	18	102	95	142	121	106	15	11	17.5	11	18	18	3,600
SWBK-40-DFD	40	66	18	48	85	18	102	95	142	121	106	15	11	17.5	11	18	18	4,200
SWBK-40-DFF	40	66	18	48	100	18	102	95	142	121	106	30	11	17.5	11	18	18	5,700
SWBK-50-DF	50	64	18	46	88	21	130	130	180	154	150	19	11	17.5	10	24	24	7,350
SWBK-50-DFD	50	84	18	66	108	21	130	130	180	154	150	19	11	17.5	10	24	24	8,940
SWBK-50-DFF	50	84	18	66	128	21	130	130	180	154	150	39	11	17.5	10	24	24	10,540

# SUPPORT UNIT : HBK SERIES



## SUPPORT UNIT FOR BALL SCREW (HIGH LOAD)

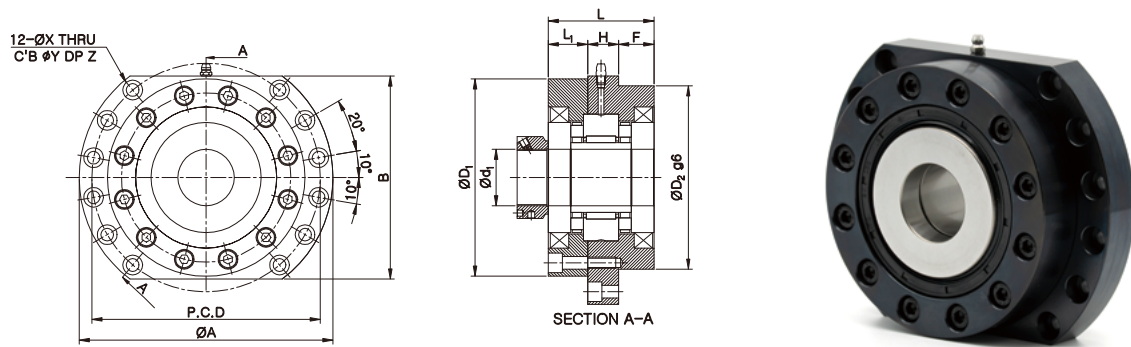

### Dimensions

Model	Dimensions(mm)												
	d <sub>1</sub>	L	L <sub>1</sub>	H	F	D <sub>1</sub>	D <sub>2</sub>	A	P.C.D	B	X	Y	Z
HBK-30	30	66	26	17	23	128	124	168	148	132	9	14	10
HBK-40	40	75	28	22	25	140	130	180	162	144	9	14	10
HBK-50	50	82	31.5	22	28.5	157	150	204	180	165	11	17.5	11

# SUPPORT UNIT

## SUPPORT UNIT FOR BALL SCREW (GREASE-INJECTION TYPE)

### Structure

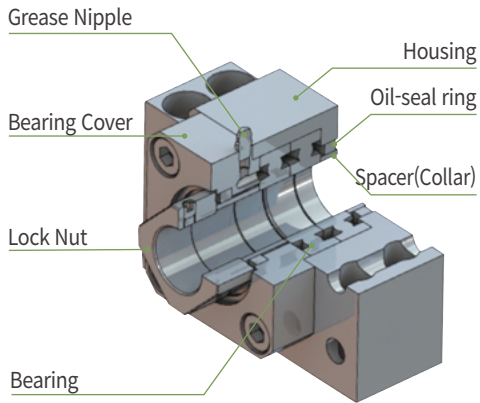

- Advance design with a nipple being attached and a passage carved on the bearing cover for a easier grease refill
- Prevention of foreign material and leak of grease by the inner oil-seal rings
- Accompanied by a high accuracy lock-nut and collars(spacer)

### Features of BK-G, FK-G & SWBK-G Series

- ▶ **Easy and Simple Grease Injection** : This structure does not require the mounted Support unit to be detached from the ball screw and grease can be simply injected through the nipple on the body.
- ▶ **Enhanced Lubrication Performance & Reduced Bearing Friction** : In terms that it is possible to frequently refill grease, it helps to reduce friction/abrasion of bearing and eventually extends the lifespan.
- ▶ **When a Support unit is mounted at a volatile circumstance or used with vertical drive motors, grease usually gets disappeared and lubrication of bearing doesn't run smoothly. Thus, this Grease injection-type Support Unit series lets you refill grease easily and solves this issue.**

### How to Order

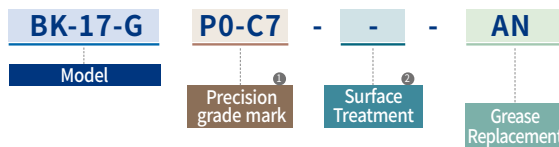

①Precision grade mark	Mark	Bearing precision grade	Preload
	P5	P5	Medium
	C8	General	Medium
	P0-C7	General	Light

②Surface Treatment	Mark	Surface Treatment
	no mark	Black Oxide
	RA	Low temperature Black Chrome Plating (Raydent)

Grease Model	Standard	LG2	AFE-CA	AFF	HT-Z1	NBU-15	XL-600
Mark	No mark	AG	AE	AF	AH	AN	AX

※ For detailed information regarding grease replacement, please refer to the guideline pages in the catalogue under the "Made-To-Order Process."

# SUPPORT UNIT

## SUPPORT UNIT FOR BALL SCREW (GREASE-INJECTION TYPE)

### How To Inject(Refill) Grease

- With the support unit installed, slowly rotate the ball screw and gradually inject grease through the grease nipple.
- Please refer to the table below for the recommended amount of grease to be injected.
- Adjust the actual injection amount according to the operating conditions and grease injection cycle of the equipment.
- Be cautious not to inject grease rapidly or in excessive quantities, as it may cause the oil seal to dislocate from its proper position.

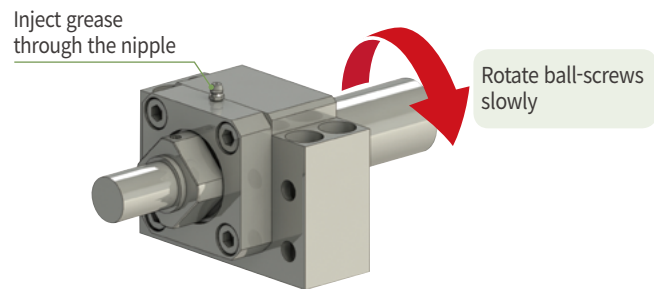

### Recommended Amount of Grease

Bearing Model	Support Unit Model	Recommended amount of grease (g)		
		Double-row (DF/DB)	Triple-row (DFD)	Four-row (DFF)
7203AW	BK-17-G	4	-	-
	FK-17-G			
7004AW	BK-20-G	4	-	-
7204AW	FK-20-G	4	-	-
7205AW	BK-25-G	4	-	-
	FK-25-G			
7206AW	BK-30-G	6	-	-
	FK-30-G			
7208AW	BK-40-G	8	-	-
	FK-40-G			
17TAC 47C	SWBK-17-G	4	6	-
20TAC 47C	SWBK-20-G	4	6	-
25TAC 62C	SWBK-25-G	4	6	-
30TAC 62C	SWBK-30-G	4	6	-
35TAC 72C	SWBK-35-G	4	6	8
40TAC 72C	SWBK-40-G	4	6	8
50TAC 100C	SWBK-50-G	4	6	8

# SUPPORT UNIT

## SUPPORT UNIT FOR BALL SCREW (GREASE-INJECTION TYPE)

### Recommended Shape of Ball Screw Shaft-End (Fixed Side / General Load)

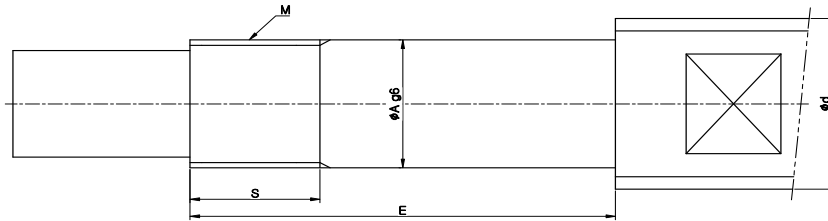

Dimensions(mm)								Lock-nut	
d	A	BK			FK			Model	Size M x pitch
		Model	E	S	Model	E	S		
Ø25 - Ø28	17	BK-17-G	65	17	FK-17-G	67	17	RN-17	M17×1.0
	20	BK-20-G	65	17	FK-20-G	73	17	RN-20	M20×1.0
Ø30 - Ø36	25	BK-25-G	80	20	FK-25-G	86	20	RN-25	M25×1.5
Ø40	30	BK-30-G	87	25	FK-30-G	87	25	RN-30	M30×1.5
Ø45	35	BK-35-G	93	28	FK-35-G	93	28	RN-35	M35×1.5
Ø50 - Ø55	40	BK-40-G	114	35	FK-40-G	114	35	RN-40	M40×1.5

### Recommended Shape of Ball Screw Shaft-End (Fixed Side / High Load)

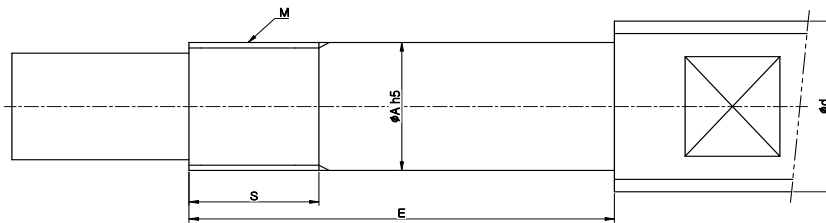

Dimensions(mm)						Lock-nut	
d	A	SWBK			Model	Size M x pitch	
		Model	E	S			
Ø25 - Ø28	17	SWBK-17-G	DF	93	23	HLRN-17	M17×1.0
			DFD	108			
Ø30 - Ø36	25	SWBK-25-G	DF	98	26	HLRN-25	M25×1.5
			DFD	113			
Ø40	30	SWBK-30-G	DF	98	26	HLRN-30	M30×1.5
			DFD	113			
Ø45	35	SWBK-35-G	DF	101	28	HLRN-35	M35×1.5
			DFD	116			
			DFF	131			
Ø50 - Ø55	40	SWBK-40-G	DF	106	30	HLRN-40	M40×1.5
			DFD	121			
			DFF	136			
Ø63 - Ø70	50	SWBK-50-G	DF	124	34	HLRN-50	M50×1.5
			DFD	144			
			DFF	164			

# SUPPORT UNIT : BK-G SERIES



SUPPORT UNIT FOR BALL SCREW (GREASE-INJECTION TYPE / GENERAL LOAD)

BK-17-G ~ BK-40-G

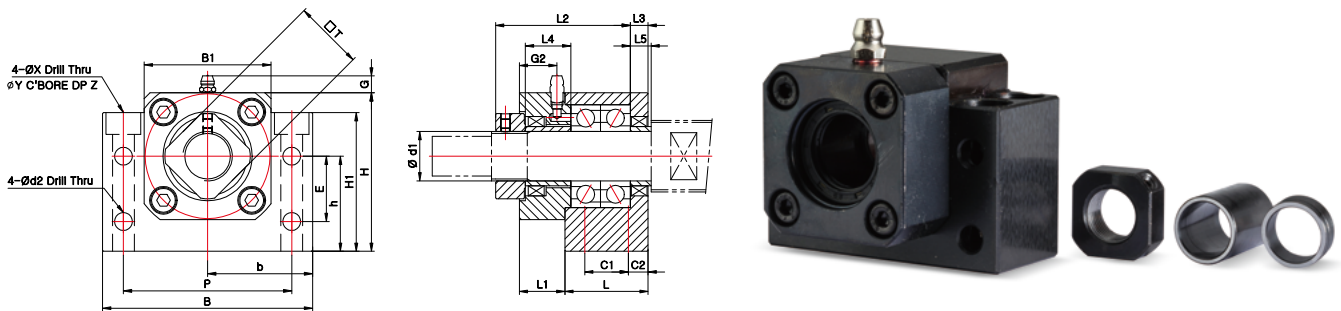

## Dimensions

Model	Sizes (mm)																									Mass (g)
	Body																				Spacer(collar)					
	d1	L	L1	L2	L3	B	H	b±0.02	h±0.02	B1	H1	E	P	C1	C2	d2	X	Y	Z	□T	G	G2		L4	L5	
BK-17-G	17	35	18	56	7	86	64	43	39	50	55	28	68	19	8	6.6	9	14	8.5	24	8.5	14	19	7	1,500	
BK-20-G	20	35	20	55	8	88	60	44	34	52	50	22	70	19	8	6.6	9	14	8.5	30	8.5	16	20	8	1,400	
BK-25-G	25	42	23	68	9	106	80	53	48	64	70	33	85	22	10	9	11	17.5	11	35	8.5	19	23	9	2,600	
BK-30-G	30	45	21.5	74.5	9	128	89	64	51	76	78	33	102	23	11	11	14	20	13	40	8.5	17.5	22.5	9	3,600	
BK-35-G	35	50	21	77	12	140	96	70	52	88	79	35	114	26	12	11	14	20	13	50	8.5	17	22	12	4,800	
BK-40-G	40	61	27	92.5	15	160	110	80	60	100	90	37	130	33	14	14	18	26	17.5	50	8.5	23	31.5	15	7,400	

# SUPPORT UNIT : FK-G SERIES



## SUPPORT UNIT FOR BALL SCREW (GREASE-INJECTION TYPE / GENERAL LOAD)

### FK-17-G ~ FK-30-G

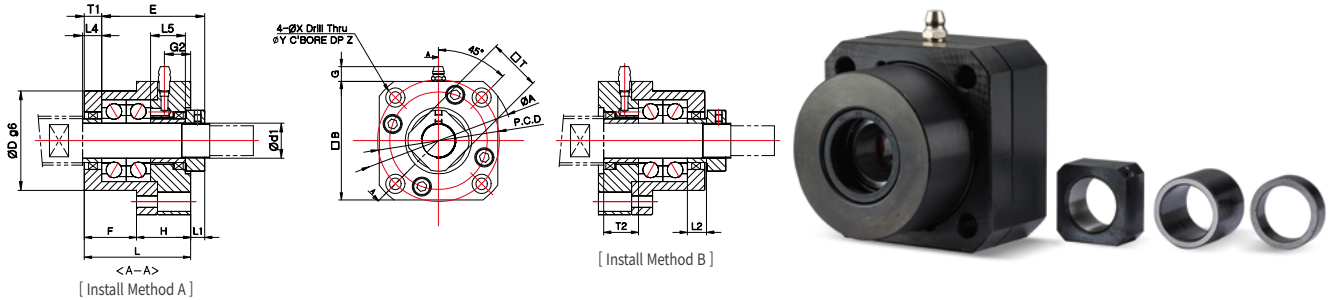

※ **Additional note for [FK-30]**

In case of choosing "Install Method B", size of spacer(collar) needs to be accordingly changed. Please contact Sung-il Customer Service team for more details.

### Dimensions

Model	Sizes (mm)																				Mass (g)	
	Body																Spacer(collar)					
	d1	L	H	F	E	D	A	P.C.D	□B	Install Method A		Install Method B		X	Y	Z	□T	G	G2	L4		L5
									L1	T1	L2	T2										
FK-17-G	17	55	32	23	56	50	77	62	61	10	9	13	12	6.6	11	20	24	8.5	16	9	19	1,100
FK-20-G	20	61	31	30	59	57	85	70	68	8	10	12	14	6.6	11	19	30	8.5	15	11	20	1,400
FK-25-G	25	65	35	30	68	63	98	80	79	13	10	20	17	9	15	21	35	8.5	17	15	23	1,800
FK-30-G	30	69.5	37.5	32	74.5	75	117	95	93	17	12	17	18	11	17.5	22.5	40	8.5	18.5	9	22.5	2,700

### FK-35-G ~ FK-40-G

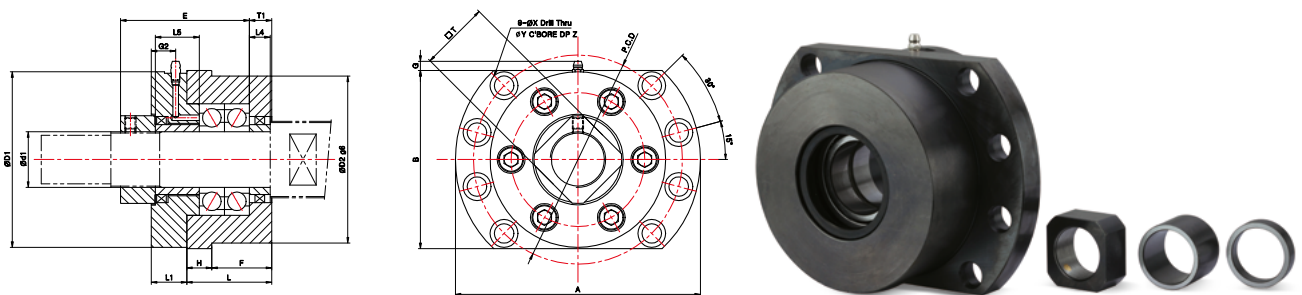

### Dimensions

Model	Sizes (mm)																				Mass (g)
	Body																Spacer(collar)				
	d1	L	H	F	E	D1	D2	A	P.C.D	B	L1	T1	X	Y	Z	□T	G	G2	L4	L5	
FK-35-G	35	48	16	32	77	112	100	154	132	120	24	12	11	17.5	11	50	3.5	16	12	22	4,700
FK-40-G	40	61	18	43	92.5	126	120	176	150	128	25.5	16	14	20	13	50	6.5	17.5	15	31.5	7,300

# SUPPORT UNIT : SWBK-G SERIES



## SUPPORT UNIT FOR BALL SCREW (GREASE-INJECTION TYPE / HIGH LOAD)

SWBK-17-G~SWBK-30-G

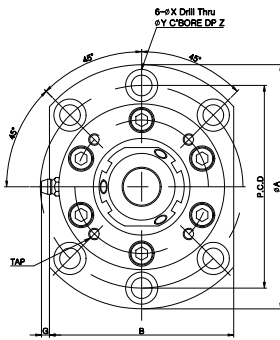

SWBK-35-G, SWBK-40-G

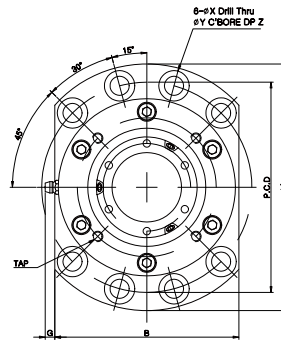

SWBK-50-G

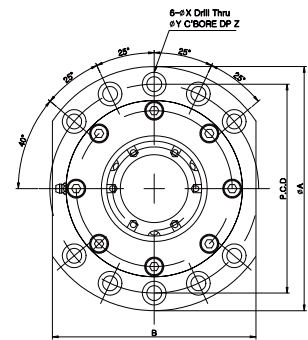

	SWBK-17-G, SWBK-20-G	SWBK-25-G, SWBK-30-G	SWBK-35-G, SWBK-40-G	SWBK-50-G
TAP	4-M5 TAP DP10	4-M6 TAP DP12	4-M6 TAP DP12	-
PCD	58	70	80	-

DF Combinations

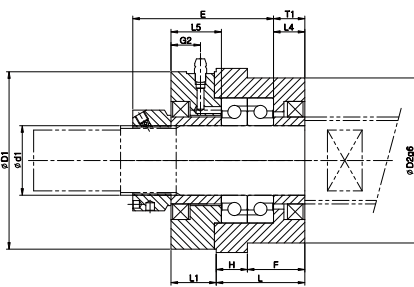

DFD Combinations

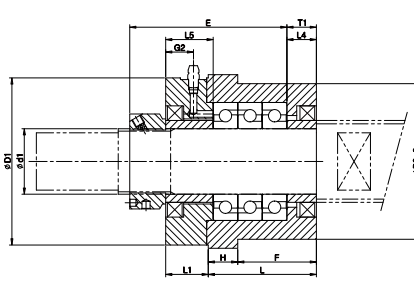

DFF Combinations

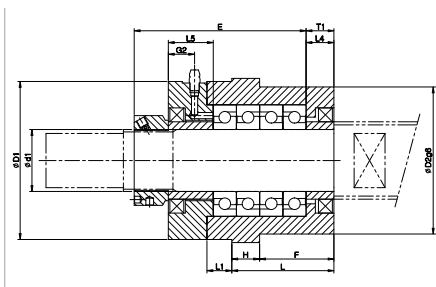

### Dimensions

Model	Sizes (mm)																			Mass (g)
	Body																	Spacer(collar)		
	d1	L	H	F	E	T1	D1	D2	A	P.C.D	B	L1	X	Y	Z	G	G2	L4	L5	
SWBK-17-G-DF	17	47	15	32	76	15	72	70	106	88	80	26	9	14	8.5	3.5	17	15	28	2,300
SWBK-17-G-DFD	17	62	15	47	91	15	72	70	106	88	80	26	9	14	8.5	3.5	17	15	28	2,700
SWBK-20-G-DF	20	47	15	32	76	15	72	70	106	88	80	26	9	14	8.5	3.5	17	15	28	2,300
SWBK-20-G-DFD	20	62	15	47	91	15	72	70	106	88	80	26	9	14	8.5	3.5	17	15	28	2,700
SWBK-25-G-DF	25	51	18	33	78	18	90	85	130	110	100	25	11	17.5	11	2.5	16	18	28	3,700
SWBK-25-G-DFD	25	66	18	48	93	18	90	85	130	110	100	25	11	17.5	11	2.5	16	18	28	4,300
SWBK-30-G-DF	30	51	18	33	78	18	90	85	130	110	100	25	11	17.5	11	2.5	16	18	28	3,600
SWBK-30-G-DFD	30	66	18	48	93	18	90	85	130	110	100	25	11	17.5	11	2.5	16	18	28	4,100
SWBK-35-G-DF	35	51	18	33	79	18	102	95	142	121	106	26	11	17.5	11	5.5	17	18	29	4,300
SWBK-35-G-DFD	35	66	18	48	94	18	102	95	142	121	106	26	11	17.5	11	5.5	17	18	29	5,000
SWBK-35-G-DFD	35	66	18	48	109	18	102	95	142	121	106	41	11	17.5	11	5.5	17	18	29	5,800
SWBK-40-G-DF	40	51	18	33	81	18	102	95	142	121	106	26	11	17.5	11	5.5	17	18	29	5,000
SWBK-40-G-DFD	40	66	18	48	96	18	102	95	142	121	106	26	11	17.5	11	5.5	17	18	29	6,000
SWBK-40-G-DFD	40	66	18	48	111	18	102	95	142	121	106	41	11	17.5	11	5.5	17	18	29	7,200
SWBK-50-G-DF	50	64	18	46	95	21	130	130	180	154	150	28	11	17.5	10	-	17	24	31	8,250
SWBK-50-G-DFD	50	84	18	66	115	21	130	130	180	154	150	28	11	17.5	10	-	17	24	31	9,610
SWBK-50-G-DFD	50	84	18	66	135	21	130	130	180	154	150	48	11	17.5	10	-	17	24	31	11,200

# SUPPORT UNIT

## SUPPORT UNIT FOR TM SCREW

### SUPPORT UNIT FOR TM SCREW - Features

- **Load Support:** Designed to support static (constant) loads in the radial direction.
- **Durability:** The double-row bearing structure increases fatigue life and ensures stable performance.
- **Precision:** Minimizes center misalignment of the bearing to achieve high positioning accuracy.

### SUPPORT UNIT FOR TM SCREW - Classification

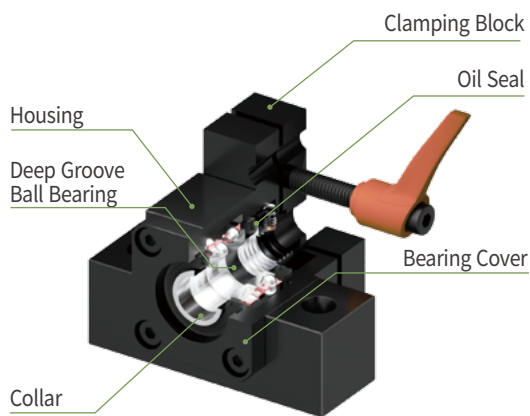

#### Fixed Side

- Easy screw fastening with simple lever operation of the clamping block
- All models are preloaded for stable support without vibration
- Equipped with an oil seal as standard to minimize lubrication loss and provide high dust protection
- Accompanied by lock-nut and collars (spacer)

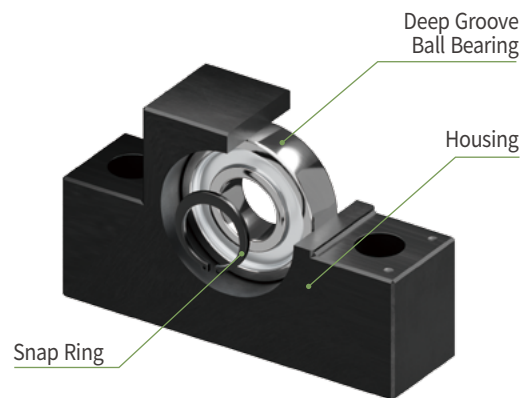

#### Supported Side

- Accompanied by a deep-groove ball bearing and a snap-ring
- Compatible with ball screw support unit EF series

# SUPPORT UNIT

## SUPPORT UNIT FOR TM SCREW

### Recommended Shape of TM Screw Shaft-end (Fixed-side)

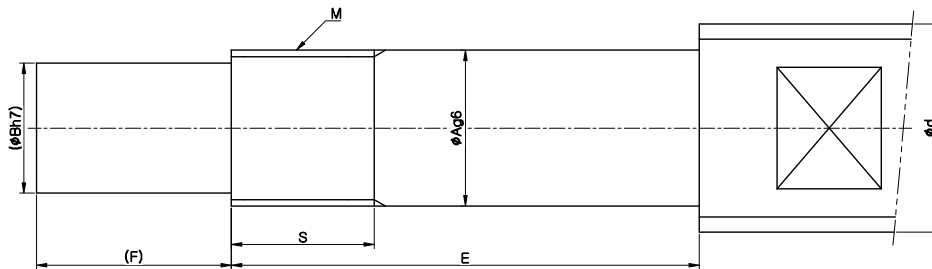

Model	Bearing	d	A	B	Lock-nut		E	F	S
					Model	Size M x pitch			
ET-8	608ZZ	10 ~ 12	8	6	RN-8	M8×1 / 0.75	35	21.5	10
ET-10	6000ZZ	10 ~ 15	10	8	RN-10	M10×1 / 0.75	36	29.5	11
ET-12	6001ZZ	14 ~ 18	12	10	RN-12	M12×1	36	29.5	11
ET-15	6002ZZ	20	15	12	RN-15	M15×1	44	34	13
ET-20	6204ZZ	25 ~ 28	20	17	RN-20	M20×1	64	44	17

### How to Order

#### Fixed Side

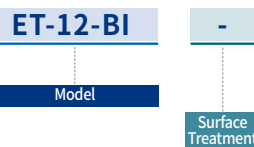

#### Supported Side

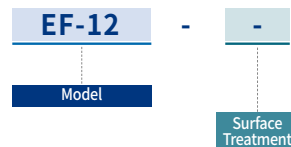

Surface Treatment	Mark	Surface Treatment
		no mark
	RA	Low temperature Black Chrome Plating (Raydent)

# SUPPORT UNIT : ET SERIES (FOR TM SCREW)



## SUPPORT UNIT FOR TM SCREW

### ET-8

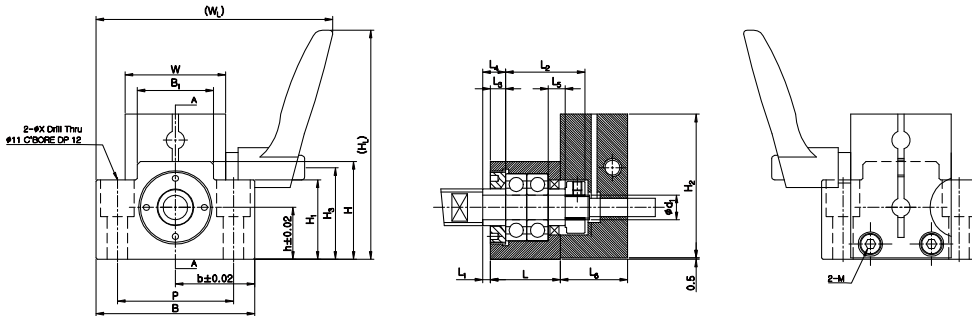

### ET-10 ~ ET-20

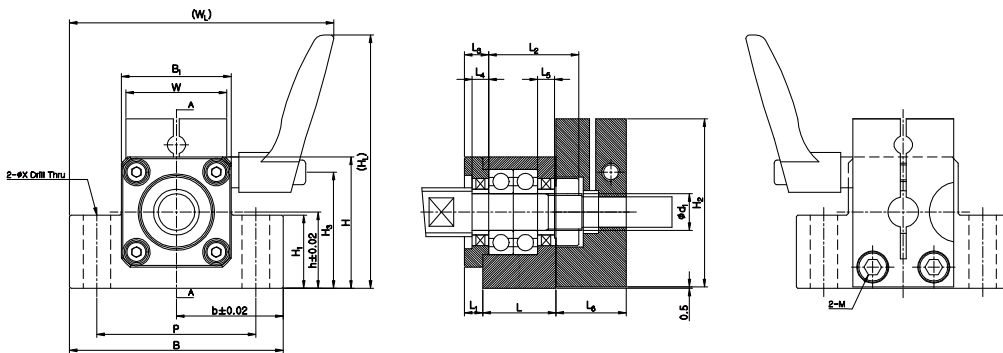

### Dimensions

Model	Body														Clamping Block				Spacer(collar)		NUT		
	d <sub>1</sub>	L	L <sub>1</sub>	L <sub>2</sub>	L <sub>3</sub>	B	H	b	h	B <sub>1</sub>	W	H <sub>1</sub>	P	X	L <sub>6</sub>	H <sub>2</sub>	H <sub>3</sub>	W <sub>L</sub>	W <sub>H</sub>	Assembly Screw		L <sub>4</sub>	L <sub>5</sub>
ET-8-BI	8	23	2.5	26	5	52	32	26	17	25	33	26	38	6.6	22	47.5	30	77.5	75	M4	7.5	5.5	RN-8
ET-10-BI	10	24	6	29.5	8	70	43	35	25	36	33	24	52	9	23	55	37.5	86.5	83	M6	5.5	5.5	RN-10
ET-12-BI	12	24	6	29.5	8	70	43	35	25	36	33	24	52	9	23	55	37.5	86.5	83	M6	5.5	5.5	RN-12
ET-15-BI	15	25	8	32	8	80	50	40	30	41	33	25	60	11	25	60	44.5	91.5	90	M6	10	6	RN-15
ET-20-BI	20	42	10	50	14	95	58	47.5	30	56	52	25	75	11	34	78	47	127.5	125.5	M6	11	11	RN-20

※ The lever may be subject to change depending on procurement or supply conditions.

# LOCK-NUT : RN SERIES



## LOCK-NUT (GENERAL LOAD)

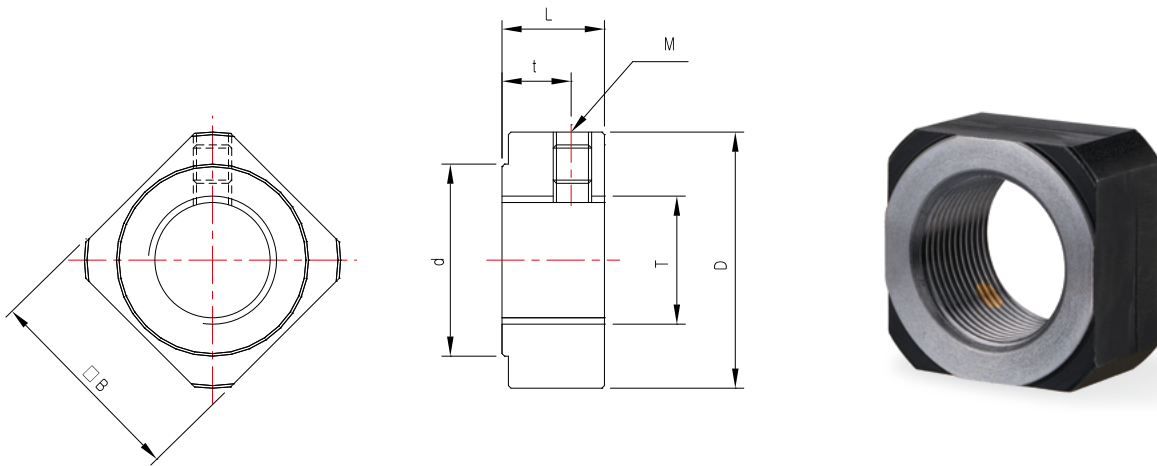

### Dimensions

Model	Sizes (mm)							Fastening Torque (N.m)	Mass (g)
	T	M	D	d	L	t	□B		
RN-4	M4×0.5	M3×0.5	11	8.5	5	2.7	10	1.6	4
RN-5	M5×0.5	M3×0.5	13	9	5	2.7	11	2	5
RN-6	M6×0.75	M3×0.5	14.5	10	5	2.7	12	2.5	5
RN-8	M8×1	M3×0.5	17	13	6.5	4	14	5	8
RN-8 (0.75P)	M8×0.75	M3×0.5	17	13	6.5	4	14	5	8
RN-10	M10×1	M4×0.7	20	15	8	5.5	16	9.5	10
RN-10 (0.75P)	M10×0.75	M4×0.7	20	15	8	5.5	16	9.5	10
RN-12	M12×1	M4×0.7	22	17	8	5.5	19	14	14
RN-15	M15×1	M4×0.7	25	21	8	4.5	22	24	15
RN-17	M17×1	M4×0.7	30	25	13	9	24	35	17
RN-20	M20×1	M4×0.7	35	26	11	7	30	48	35
RN-25	M25×1.5	M5×0.8	43	33	15	10	35	86	45
RN-30	M30×1.5	M6×1	48	39	20	14	40	128	80
RN-35	M35×1.5	M8×1.25	60	46	21	14	50	192	130
RN-40	M40×1.5	M8×1.25	63	51	25	18	50	256	235

### Material for RN

Model	Body		Accessories	
	Material	Surface Treatment	Set-screw	Crush pad
RN-□□	Steel	Black Oxide	SCM435	Brass

# LOCK-NUT : RNSS SERIES



## LOCK-NUT (GENERAL LOAD)

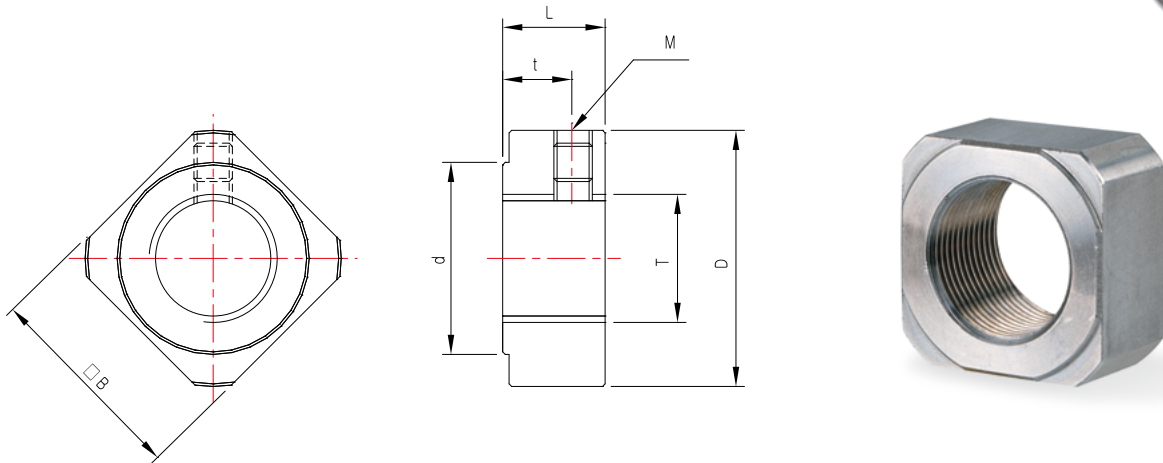

### Dimensions

Model	Sizes (mm)							Fastening Torque (N.m)	Mass (g)
	T	M	D	d	L	t	□B		
RNSS-4	M4×0.5	M3×0.5	11	8.5	5	2.7	10	1.6	4
RNSS-5	M5×0.5	M3×0.5	13	9	5	2.7	11	2	5
RNSS-6	M6×0.75	M3×0.5	14.5	10	5	2.7	12	2.5	5
RNSS-8	M8×1	M3×0.5	17	13	6.5	4	14	5	8
RNSS-8 (0.75P)	M8×0.75	M3×0.5	17	13	6.5	4	14	5	8
RNSS-10	M10×1	M4×0.7	20	15	8	5.5	16	9.5	10
RNSS-10 (0.75P)	M10×0.75	M4×0.7	20	15	8	5.5	16	9.5	10
RNSS-12	M12×1	M4×0.7	22	17	8	5.5	19	14	14
RNSS-15	M15×1	M4×0.7	25	21	8	4.5	22	24	15
RNSS-17	M17×1	M4×0.7	30	25	13	9	24	35	17
RNSS-20	M20×1	M4×0.7	35	26	11	7	30	48	35
RNSS-25	M25×1.5	M5×0.8	43	33	15	10	35	86	45
RNSS-30	M30×1.5	M6×1	48	39	20	14	40	128	80
RNSS-35	M35×1.5	M8×1.25	60	46	21	14	50	192	130
RNSS-40	M40×1.5	M8×1.25	63	51	25	18	50	256	235

### Material for RNSS

Model	Body		Accessories	
	Material	Surface Treatment	Set-screw	Crush pad
RNSS-□□	Stainless Steel	-	Stainless Steel	Stainless Steel

# LOCK-NUT : RNSB SERIES



## LOCK-NUT (GENERAL LOAD)

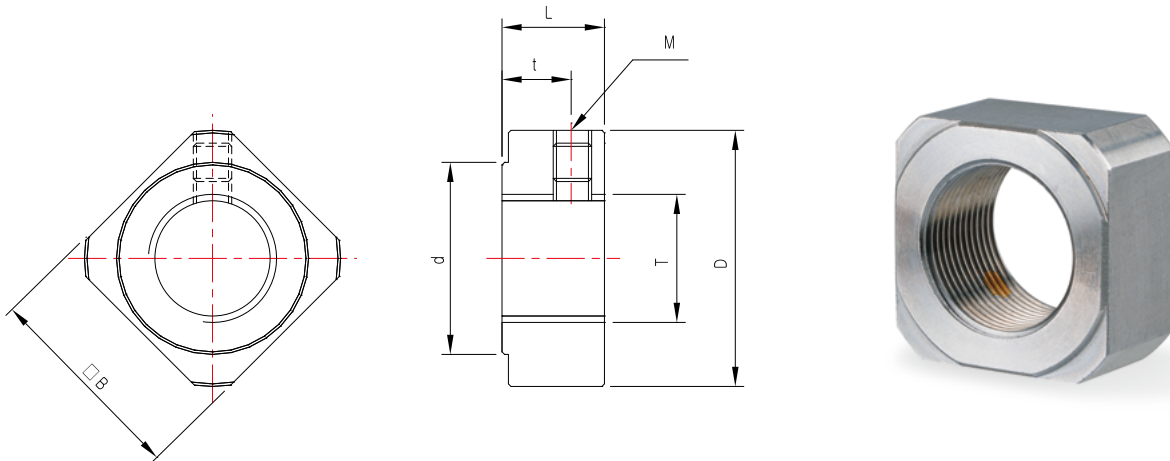

### Dimensions

Model	Sizes (mm)							Fastening Torque (N.m)	Mass (g)
	T	M	D	d	L	t	$\square B$		
RNSB-4	M4×0.5	M3×0.5	11	8.5	5	2.7	10	1.6	4
RNSB-5	M5×0.5	M3×0.5	13	9	5	2.7	11	2	5
RNSB-6	M6×0.75	M3×0.5	14.5	10	5	2.7	12	2.5	5
RNSB-8	M8×1	M3×0.5	17	13	6.5	4	14	5	8
RNSB-8 (0.75P)	M8×0.75	M3×0.5	17	13	6.5	4	14	5	8
RNSB-10	M10×1	M4×0.7	20	15	8	5.5	16	9.5	10
RNSB-10 (0.75P)	M10×0.75	M4×0.7	20	15	8	5.5	16	9.5	10
RNSB-12	M12×1	M4×0.7	22	17	8	5.5	19	14	14
RNSB-15	M15×1	M4×0.7	25	21	8	4.5	22	24	15
RNSB-17	M17×1	M4×0.7	30	25	13	9	24	35	17
RNSB-20	M20×1	M4×0.7	35	26	11	7	30	48	35
RNSB-25	M25×1.5	M5×0.8	43	33	15	10	35	86	45
RNSB-30	M30×1.5	M6×1	48	39	20	14	40	128	80
RNSB-35	M35×1.5	M8×1.25	60	46	21	14	50	192	130
RNSB-40	M40×1.5	M8×1.25	63	51	25	18	50	256	235

### Material for RNSB

Model	Body		Accessories	
	Material	Surface Treatment	Set-screw	Crush pad
RNSB-□□	Stainless Steel	-	Stainless Steel	Brass

# LOCK-NUT : ZN SERIES



## LOCK-NUT (GENERAL LOAD)

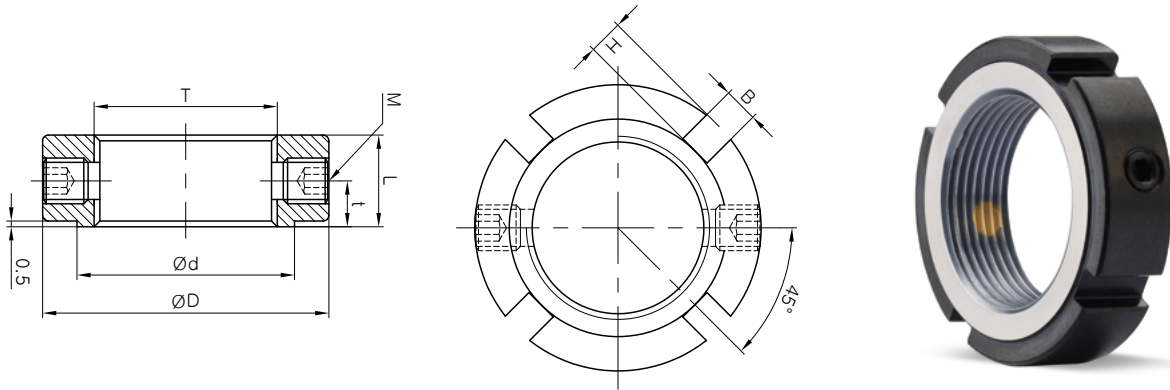

### Dimensions

Model	Sizes (mm)								Fastening Torque (N.m)	Mass (g)
	T	M	D	d	L	t	B	H		
ZN-8	M8×1.0	2-M4×0.7	16	12	8	4	3	2	5	7
ZN-8 (0.75P)	M8×0.75	2-M4×0.7	16	12	8	4	3	2	5	7
ZN-10	M10×1.0	2-M4×0.7	18	14	8	4	3	2	9.5	9
ZN-10 (0.75P)	M10×0.75	2-M4×0.7	18	14	8	4	3	2	9.5	9
ZN-12	M12×1.0	2-M4×0.7	22	16	8	4	3	3	14	13
ZN-15	M15×1.0	2-M4×0.7	25	19	8	4	3	3	24	17
ZN-17	M17×1.0	2-M5×0.8	28	21	10	5	4	3	35	25
ZN-20	M20×1.0	2-M5×0.8	32	25	10	5	4	3	48	33
ZN-25	M25×1.5	2-M6×1	38	31	12	6	5	3	86	54
ZN-30	M30×1.5	2-M6×1	45	38	12	6	5	3	128	77
ZN-35	M35×1.5	2-M6×1	52	45	12	6	5	3	192	103
ZN-40	M40×1.5	2-M6×1	58	50	14	7	6	3	256	143

### Material for ZN

Model	Body		Accessories	
	Material	Surface Treatment	Set-screw	Crush pad
ZN-□□	Steel	Black Oxide	SCM435	Brass

# LOCK-NUT : HLRN SERIES



## LOCK-NUT (HIGH LOAD)

### HLRN-17

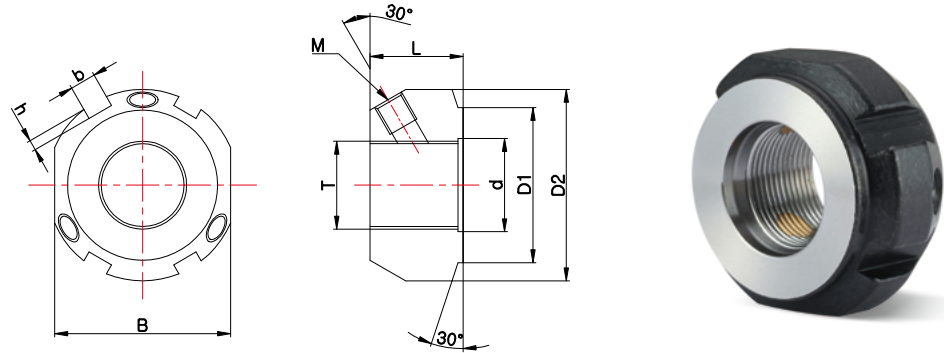

### HLRN-20 ~ HLRN-40

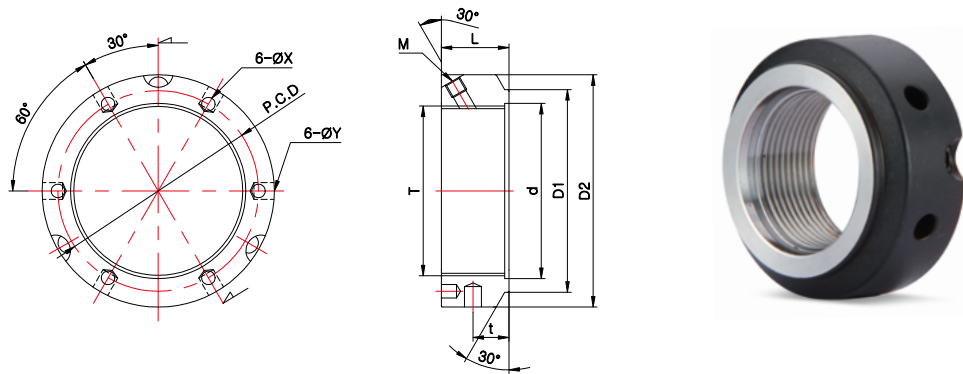

### Dimensions

Model	Sizes (mm)													Fastening Torque (N.m)
	T	M	d	D1	D2	t	L	X	Y	P.C.D	b	h	B	
HLRN-17	M17×1.0	M6×6	18	30	37	-	18	-	-	-	5	2.5	30	41
HLRN-20	M20×1.0	M6×6	21	30	38	10	18	4.3	4	29				45
HLRN-25	M25×1.5	M6×6	26	35	42	11	20	4.3	4	32.5				87
HLRN-30	M30×1.5	M6×6	31	40	48	11	20	4.3	5	40.5				105
HLRN-35	M35×1.5	M6×6	36	47	53	11	20	4.3	5	45.5				145
HLRN-40	M40×1.5	M6×6	41	52	58	12	22	4.3	5	50.5				160

### Material for HLRN

Model	Body		Accessories	
	Material	Surface Treatment	Set-screw	Crush pad
HLRN-□□	Steel	Black Oxide	SCM435	Brass

# BEARING UNIT



## BEARING UNIT

### SBS Series

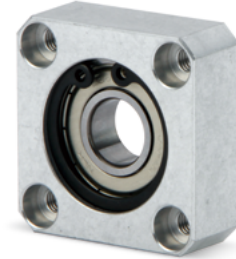
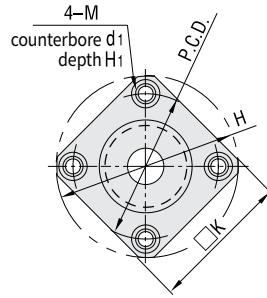
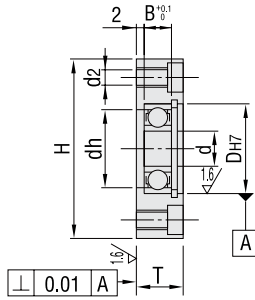

### Dimensions

Model	Sizes (mm)												Bearing
	d	D	B	H	□K	T	dh	P.C.D	M	d2	d1	H1	
SBS-8	8	22	7	45	36	12	18	35	5	4.3	8	4.4	608ZZ
SBS-10	10	26	8	50	39	13	22	40	5	4.3	8	4.4	6000ZZ
SBS-12	12	28	8	52	40	13	24	42	5	4.3	8	4.4	6001ZZ
SBS-15	15	32	9	60	46	14	28	48	6	5.2	9.5	5.4	6002ZZ
SBS-17	17	40	12	72	54	18	34	60	6	5.2	9.5	5.4	6203ZZ
SBS-20	20	42	12	77	59	18	36	64	8	6.8	11	6.5	6004ZZ
SBS-25	25	52	15	94	72	22	45	78	10	8.5	14	8.6	6205ZZ
SBS-30	30	62	16	104	79	23	55	88	10	8.5	14	8.6	6206ZZ

### SBD Series

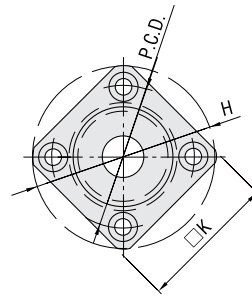
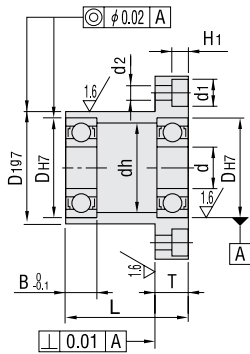

### Dimensions

Model	Sizes (mm)													Bearing
	d	D	D1	B	L	H	□K	T	dh	P.C.D	d2	d1	H1	
SBD-8	8	22	27	7	25	45	36	8	18	35	4.3	8	4.4	608ZZ
SBD-10	10	26	32	8	30	50	39	8	22	40	4.3	8	4.4	6000ZZ
SBD-12	12	28	34	8	30	52	40	8	24	42	4.3	8	4.4	6001ZZ
SBD-15	15	32	38	9	35	60	46	10	28	48	5.2	9.5	5.4	6002ZZ
SBD-17	17	40	48	12	45	72	54	10	34	60	5.2	9.5	5.4	6203ZZ
SBD-20	20	42	50	12	45	77	59	11	36	64	6.8	11	6.5	6004ZZ
SBD-25	25	52	60	15	45	94	72	13	45	78	8.5	14	8.6	6205ZZ
SBD-30	30	62	70	16	50	104	79	13	55	88	8.5	14	8.6	6206ZZ





Customer Satisfaction

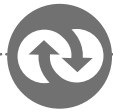

Speed

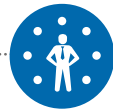

Ownership



Innovation



#### HQ (KOREA)

Address: 25, Seounsandanro-1gil, Gyeong-gu, Incheon Korea 21072  
TEL: +82-32-719-3456 (+82-2-2613-9933) | FAX: +82-32-719-3733 (+82-2-2613-8911)

Website: [www.sungilfa.co.kr/eng](http://www.sungilfa.co.kr/eng)  
Email: [ovsales1@sungilfa.co.kr](mailto:ovsales1@sungilfa.co.kr)

#### Overseas Branches

China: NO.229 Chengnan Road, new Wu District, Wuxi, Jiangsu, 214028, CHINA  
Japan: #616 #635 the SOHO AOMI2-7-4, KOTO-KU, 135-0064, JAPAN

Quick access to  
SIM (QR)

